

GREENKISS



PAOLOCASTELLI

La gamma

The range

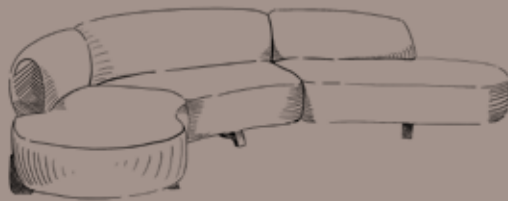

GREENKISS

PAOLO CASTELLI

Fine furniture & Lighting

TAVOLI TABLES	p. 3
SEDUTE SEATING	p. 12
DIVANI SOFAS	p. 16
POLTRONE ARMCHAIRS	p. 20
LIBRERIE e CONTENITORI BOOKCASES & STORAGE	p. 24
LETTI BED	p. 28
LUCI LIGHTING	p. 31

GREENKISS



PAOLO CASTELLI

Tavoli

Tables

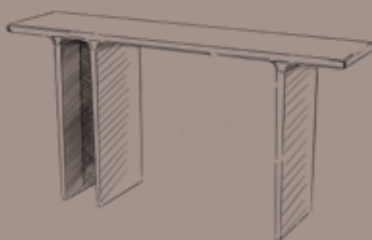
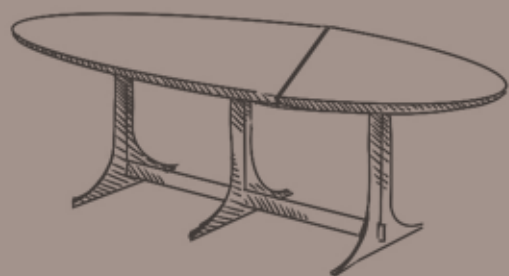

GREENKISS

Arche Dining table

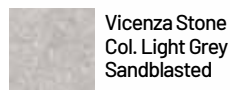

Vicenza Stone
Col. Light Grey
Sandblasted



Metal Finish
Champagne
Orbital

Alternative top options

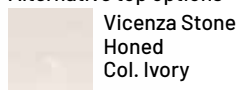

Vicenza Stone
Honed
Col. Ivory

Alternative top options



Reconstituted
stone col. Ivory
with large grey
grit stones
cod. 305



Reconstituted
stone - col. Ivory
with large white
grit stones
cod. 204



Reconstituted
fine grained
stone Col.
White
cod. 78



Reconstituted
fine grained
stone Col.
Grey
cod. 115



Natural carbon
reconstituted
with recycled
brass shavings

Tavolo caratterizzato da geometrie precise e pulite, in cui l'arco diventa struttura portante come in un'architettura razionalista.

La struttura è realizzata da lamiera metalliche disposte a croce, sagomate ad arco a taglio laser, in finitura color champagne a satinatura orbitale. Il piano può essere realizzato in pietra di Vicenza sabbiata col. grigio o levigata col. avorio (sp. piano 3cm). In alternativa è disponibile la versione in pietra ricostituita o carbone naturale ricostituito con trucioli di ottone da recupero (sp. piano 2 cm). Una serie di decori metallici col. champagne satinato impreziosisce il top in un gioco di contrasti tra materiali.

Table characterised by precise, clear-cut geometries, in which the arch becomes the load-bearing structure typical of rationalist architecture.

The metal structure is built in a cross-shaped, laser-cut arch arrangement, presented in a champagne colour with an orbital satin finish. The top is made of Vicenza stone sandblasted col. light grey or honed col. ivory- 3cm thick. Also available the top made in reconstituted coarse grained stone or natural carbon reconstituted with recycled brass shavings (both option have 2cm-thick top). Metallic inserts col. champagne mat embellish the top with a delightful contrasting effect between the materials.

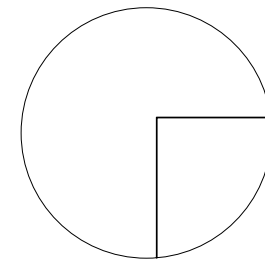

110 cm

[43 5/16 "]

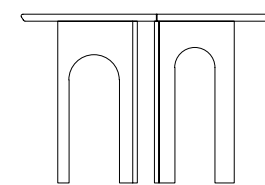

74 cm

[29 1/8 "]

VICENZA STONE | TAV.ARCH.300

Metal structure champagne orbital satin finished. Top detail in metal col. champagne matt
Top in Vicenza stone. Available finishes: Vicenza stone col. light grey sandblasted, Vicenza stone col. ivory honed

COARSE / RECONSTITUTED STONES | TAV.ARCH.301

Metal structure champagne orbital satin finished. Top detail in metal col. champagne matt
Top in reconstituted stones. Available finishes: col. ivory with large white grit stones cod. 204; col. ivory with large grey grit stones cod. 305; fine grained stone col. white cod. 78; fine-grained stone col. grey cod. 115; natural carbon reconstituted with recycled brass shavings.

GREENKISS

Arche Coffee tables



Ø45

Ø50



Vicenza Stone
Col. Light Grey
Sandblasted



Metal Finish
Champagne
Orbital

Alternative top options

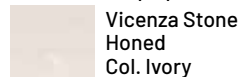

Vicenza Stone
Honed
Col. Ivory

Alternative top options



Reconstituted
stone col. Ivory
with large grey
grit stones
cod. 305



Reconstituted
stone - col. Ivory
with large white
grit stones
cod. 204



Reconstituted
fine grained
stone Col.
White
cod. 78



Reconstituted
fine grained
stone Col.
Grey
cod. 115



Natural carbon
reconstituted
with recycled
brass shavings

Tavolini caratterizzati da geometrie precise e pulite, in cui l'arco diventa struttura portante come in un'architettura razionalista. La struttura è realizzata da lamiere metalliche disposte a croce, sagomate ad arco a taglio laser, in finitura color champagne a satinatura orbitale. Il piano può essere realizzato in pietra di Vicenza sabbata col. grigio o levigata col. avorio (sp. piano 3cm). In alternativa è disponibile la versione in pietra ricostituita o carbone naturale ricostituito con trucioli di ottone da recupero (sp. piano 2 cm). Una serie di decori metallici col. champagne satinato impreziosisce il top in un gioco di contrasti tra materiali.

Side and coffee tables characterised by precise, clear-cut geometries, in which the arch becomes the load-bearing structure typical of rationalist architecture. The metal structure is built in a cross-shaped, laser-cut arch arrangement, presented in a champagne colour with an orbital satin finish. The top is made of Vicenza stone sandblasted col. light grey or honed col. ivory- 3cm thick. Also available the top made in reconstituted coarse grained stone or natural carbon reconstituted with recycled brass shavings (both option have 2cm-thick top). Metallic inserts col. champagne mat embellish the top with a delightful contrasting effect between the materials.

Ø45

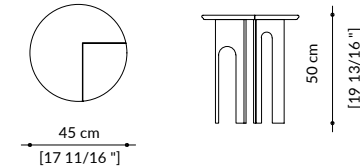

Ø45 VICENZA STONE | TAV.ARCH.110

Metal structure champagne orbital satin finished. Top detail in metal col. champagne matt
Top in Vicenza stone. Available finishes: Vicenza stone col. light grey sandblasted, Vicenza stone col. ivory honed

Ø45 COARSE / RECONSTITUTED STONES | TAV.ARCH.111

Metal structure champagne orbital satin finished. Top detail in metal col. champagne matt
Top in reconstituted stones. Available finishes: col. ivory with large white grit stones cod. 204; col. ivory with large grey grit stones cod. 305; fine grained stone col. white cod. 78; fine-grained stone col. grey cod. 115; natural carbon reconstituted with recycled brass shavings.

Ø50

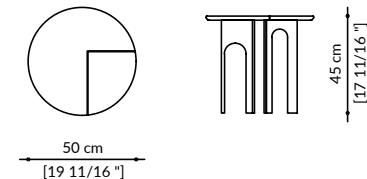

Ø50 VICENZA STONE | TAV.ARCH.120

Metal structure champagne orbital satin finished. Top detail in metal col. champagne matt
Top in Vicenza stone. Available finishes: Vicenza stone col. light grey sandblasted, Vicenza stone col. ivory honed

Ø50 COARSE / RECONSTITUTED STONES | TAV.ARCH.121

Metal structure champagne orbital satin finished. Top detail in metal col. champagne matt
Top in reconstituted stones. Available finishes: col. ivory with large white grit stones cod. 204; col. ivory with large grey grit stones cod. 305; fine grained stone col. white cod. 78; fine-grained stone col. grey cod. 115; natural carbon reconstituted with recycled brass shavings.

GREENKISS

Arche Coffee tables



Ø90



Vicenza Stone
Col. Light Grey
Sandblasted



Metal Finish
Champagne
Orbital

Alternative top options

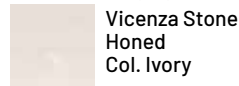

Vicenza Stone
Honed
Col. Ivory

Alternative top options



Reconstituted
stone col. Ivory
with large grey
grit stones
cod. 305



Reconstituted
stone - col. Ivory
with large white
grit stones
cod. 204



Reconstituted
fine grained
stone Col.
White
cod. 78



Reconstituted
fine grained
stone Col.
Grey
cod. 115



Natural carbon
reconstituted
with recycled
brass shavings

Tavolini caratterizzati da geometrie precise e pulite, in cui l'arco diventa struttura portante come in un'architettura razionalista. La struttura è realizzata da lamiera metalliche disposte a croce, sagomate ad arco a taglio laser, in finitura color champagne a satinatura orbitale. Il piano può essere realizzato in pietra di Vicenza sabbata col. grigio o levigata col. avorio (sp. piano 3cm). In alternativa è disponibile la versione in pietra ricostituita o carbone naturale ricostituito con trucioli di ottone da recupero (sp. piano 2 cm). Una serie di decori metallici col. champagne satinato impreziosisce il top in un gioco di contrasti tra materiali.

Coffee tables characterised by precise, clear-cut geometries, in which the arch becomes the load-bearing structure typical of rationalist architecture. The metal structure is built in a cross-shaped, laser-cut arch arrangement, presented in a champagne colour with an orbital satin finish. The top is made of Vicenza stone sandblasted col. light grey or honed col. ivory- 3cm thick. Also available the top made in reconstituted coarse grained stone or natural carbon reconstituted with recycled brass shavings (both option have 2cm-thick top). Metallic inserts col. champagne mat embellish the top with a delightful contrasting effect between the materials.

Ø90

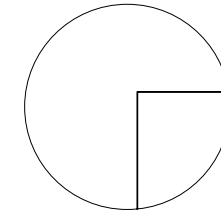

90 cm
[35 7/16"]

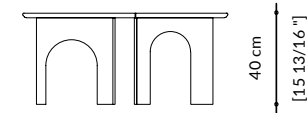

40 cm
[15 13/16"]

Ø90 VICENZA STONE | TAV.ARCH.130

Metal structure champagne orbital satin finished. Top detail in metal col. champagne matt
Top in Vicenza stone. Available finishes: Vicenza stone col. light grey sandblasted, Vicenza stone col. ivory honed

Ø90 COARSE / RECONSTITUTED STONES | TAV.ARCH.131

Metal structure champagne orbital satin finished. Top detail in metal col. champagne matt
Top in reconstituted stones. Available finishes: col. ivory with large white grit stones cod. 204; col. ivory with large grey grit stones cod. 305; fine grained stone col. white cod. 78; fine-grained stone col. grey cod. 115; natural carbon reconstituted with recycled brass shavings.

GREENKISS

Egg table



Vicenza Stone
Col. Light Grey
Sandblasted



Metal Finish
Champagne
Orbital

Alternative top options



Vicenza Stone
Honed
Col. Ivory

Tavolo da pranzo con struttura in metallo finitura color champagne a satinatura orbitale. Il top è realizzato in pietra di Vicenza sabbata col. grigio o levigata col. avorio caratterizzata dalla presenza di macrofossili, arricchito da un inserto in profilo metallico color champagne opaco.

Dining table with metal frame and champagne-coloured finish, with orbital satin finish. The top is made of Vicenza stone sandblasted col. grey or honed col. ivory with macrofossils, embellished with a matt champagne-coloured metal insert.

74 cm
[29 1/4 "]

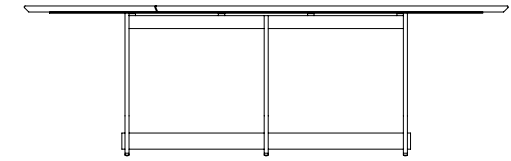

120 cm
[47 1/4 "]

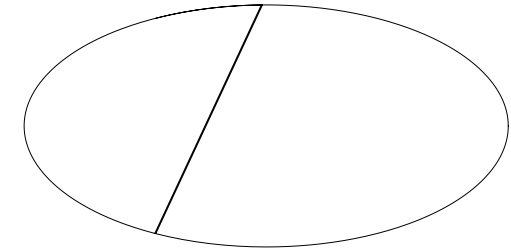

240 cm
[94 1/2 "]

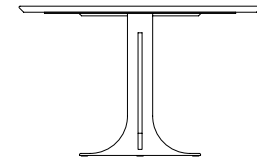
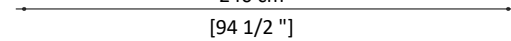

EGG TABLE | TAV.EGGT.300

Metal structure champagne orbital satin finished. Top detail in metal col. champagne matt
Top in Vicenza stone. Available finishes: Vicenza stone col. light grey sandblasted, Vicenza stone col. ivory honed

GREENKISS

Cesar Console



Faenza Ceramic
Raw finish
Col. Optical White



Faenza Ceramic
Glossy finish
Col. Optical White



Pressed fabric
and resin

Console monolitica dalle forme scultoree ed iconiche. La base è realizzata in ceramica artigianale di Faenza di colore bianco, con alternanza di finitura smaltata e opaca materica negli elementi che la compongono. Il top, di spessore 5 cm, è realizzato con un'anima in mattoni di tessuto riciclato pressato e finitura esterna in resina biologica trasparente.

Monolithic console with sculptural, iconic shapes. The elements comprising the white handmade Faenza ceramic base alternate between a glazed and matt finish. The 5-cm thick top is made of a pressed recycled fabric blocks with an external transparent eco-friendly resin finish.

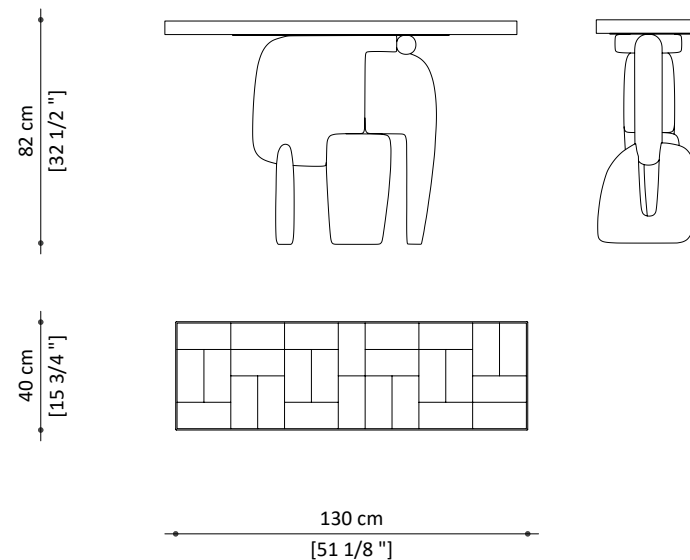

CESAR CONSOLE | TAV.CESA.200

Pressed fabric and resin top - Base in ceramic from Faenza - mat and glossy

GREENKISS

Selima Console

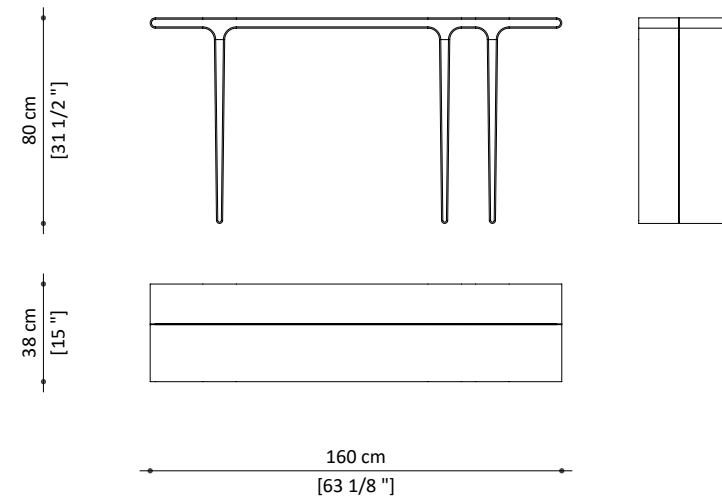

Wood
Walnut Stained
Ashwood



Metal Finish
Champagne
Matt

Console in frassino ecosostenibile non selezionato, disponibile in tre versioni: con finitura acetica, sbiancata o tinto noce con finitura poro aperto. Con questo procedimento il poro del legno viene volutamente lasciato aperto permettendo all'essenza di mantenere il suo aspetto naturale. I profili della console sono impreziositi da inserti metallici color champagne opaco.

Alternative options



Wood
Ashwood with
acetic finish



Wood
Bleached
Ashwood

Console made of solid eco-friendly ash discarded, available in three options: natural ash with acetic finish, bleached or walnut-stained version with open pore finish. By this process the wood pores are deliberately left open, thereby allowing the veneer to retain its natural appearance. The console frames are embellished with matt champagne-coloured metal inserts.

SELIMA CONSOLE | TAV.SELI.200

Metal details champagne matt - Solid wood frame

Available wood finishes: walnut stained ash - bleached ash - acetic finish

GREENKISS

Hyperbole Coffee table



Ø32



Ø40



Ø80



Recycled glass and resin
Multicoloured



Metal Finish
Champagne
Orbital



Black antique
granite striped

Ø32 - Tavolino con piano in vetro riciclato multicolore e resina, con struttura in metallo finitura color champagne a satinatura orbitale.

Ø40 - Tavolino con piano in vetro riciclato multicolore e resina, con struttura in metallo finitura color champagne a satinatura orbitale.

Ø80 - Tavolino con piano in granito antico nero con texture rigata. Struttura in metallo colore champagne a satinatura orbitale.

Ø32 - Coffee table with seat made of multicoloured recycled glass and resin, with metal frame and champagne-coloured orbital satin finish.

Ø40 - Coffee table with top made of multicoloured recycled glass and resin, with metal frame and champagne-coloured orbital satin finish.

Ø80 - Coffee table with black antique granite striped top, embellished with metal mat insert champagne coloured. Metal frame with champagne-coloured orbital satin finish.

Ø32

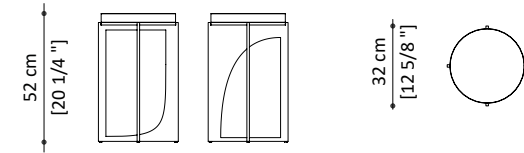

Ø32 | TAV.HYPE.130

Multicoloured recycled glass and resin top - Metal base - champagne orbital satin finish

Ø40

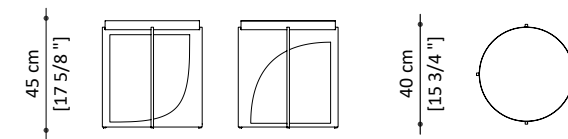

Ø40 | TAV.HYPE.110

Multicoloured recycled glass and resin top - Metal base - champagne orbital satin finish

Ø80

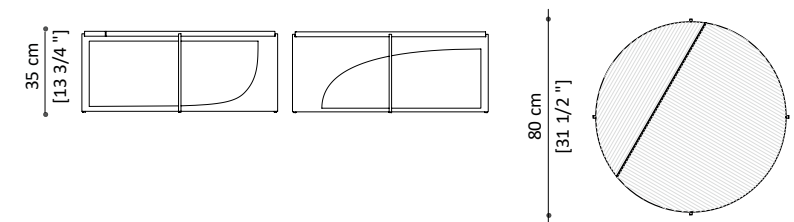

Ø80 | TAV.HYPE.120

Black antique granite striped top - Metal base - champagne orbital satin finish

GREENKISS

Kaala

Coffee table



Wood
Walnut Stained
Ashwood



Metal Finish
Champagne
Matt



Vietri Ceramic
Glossy finish
Col. Optical White

Tavolino con base in metallo color champagne opaco, ricoperto da lastre realizzate in ceramica artigianale di Vietri smaltata bianca. L'accostamento dei due materiali crea un elegante inserto metallico.

Il top è realizzato in legno di frassino non selezionato ecosostenibile tinto noce, rifinito con inserto metallico color champagne opaco.

Coffee table with structure in matt champagne-coloured metal, covered by handmade white glazed Vietri ceramic. The combination of two materials creates an elegant metal trim. The top is made by eco-friendly discarded walnut-stained ash wood, with a matt metal insert champagne-coloured.

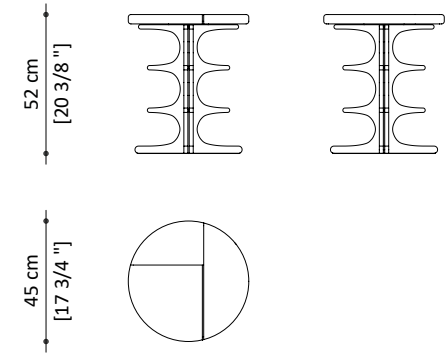

KAALA COFFEE TABLE | TAV.KAAL.100

Walnut stained ash top with metal insert champagne mat
Base covered by handmade white glazed Vietri ceramic col. White

GREENKISS



PAOLO CASTELLI

Sedie Chairs



GREENKISS

Gio Chair

C



Alternative options



Wood
Walnut Stained
Ashwood



Wood
Ashwood with
acetic finish



Wood
Bleached
Ashwood

Sedia da pranzo realizzata interamente in massello di frassino ecosostenibile, disponibile in tre versioni: con finitura acetica, sbiancata o tinto noce con finitura poro aperto. Con questo procedimento il poro del legno viene volutamente lasciato aperto permettendo all'essenza di mantenere il suo aspetto naturale.

Dining chair made entirely of solid eco-friendly ash discarded, available in three options: natural ash with acetic finish, bleached or walnut-stained version with open pore finish. By this process the wood pores are deliberately left open, thereby allowing the veneer to retain its natural appearance.

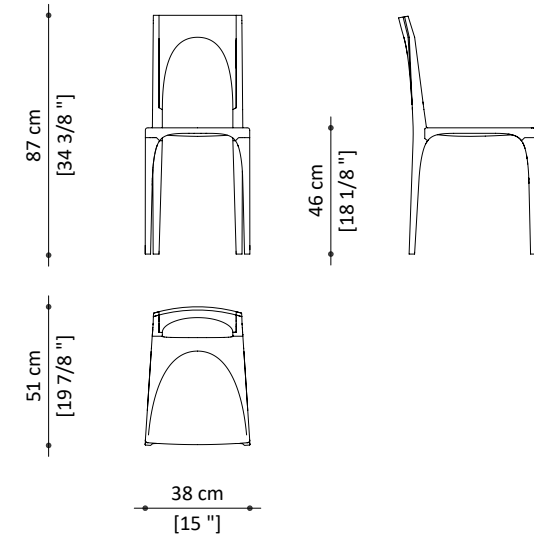

GIO CHAIR | SED.GIOC.700

Solid wood frame

Available wood finishes: walnut stained ash - bleached ash - acetic finish

GREENKISS
Selima
 Chair



Wood
 Walnut Stained
 Ashwood



Metal Finish
 Champagne
 Matt



Fabric
 Wool Bouclé
 Col. 03 Linen

Sedia da pranzo realizzata interamente in massello di frassino ecosostenibile, disponibile in tre versioni: con finitura acetica, sbiancata o tinto noce con finitura poro aperto. Con questo procedimento il poro del legno viene volutamente lasciato aperto permettendo all'essenza di mantenere il suo aspetto naturale. Schienale e seduta con rivestimento non sfoderabile in lana bouclé, tessuto misto lino, lino o econabuk. I dettagli della struttura sono in metallo color champagne opaco.

Dining chair made entirely of solid eco-friendly ash discarded, available in three options: natural ash with acetic finish, bleached or walnut-stained version with open pore finish. By this process the wood pores are deliberately left open, thereby allowing the veneer to retain its natural appearance. Back and seat with unremovable covering in bouclé wool, blended linen, linen fabric or econabuk. Frame details made of champagne-coloured metal, polished finish.

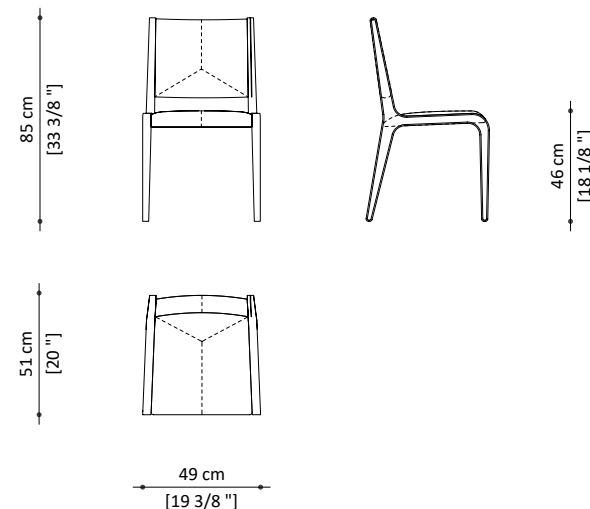

BLENDED LINEN / LINEN / ECONABUK | SED.SELI.700.SUP

Metal details champagne matt - Solid wood frame - Covered in blended linen, linen or econabuk
 Available wood finishes: walnut stained ash - bleached ash - acetic finish

WOOL | SED.SELI.700.DEL

Metal details champagne matt - Solid wood frame - Covered in bouclé wool fabric
 Available wood finishes: walnut stained ash - bleached ash - acetic finish

GREENKISS Theo Chair



BIGSEE
WOODDESIGN
AWARD 2020
WINNER



Wood
Bleached
Ashwood

Sedia a 6 gambe disegnata per enfatizzare la leggerezza del legno e l'eleganza della tradizione artigianale italiana. Struttura a vista in frassino sbiancato non selezionato con finitura poro aperto. Con questo procedimento il poro del legno viene volutamente lasciato aperto permettendo all'essenza di mantenere il suo aspetto naturale.

6-leg chair designed for emphasising the lightness of the wood and the elegance of Italian artisan tradition. Solid wooden structure made in bleached ecofriendly discarded ash with open pore finish. By this process the wood pores are deliberately left open, thereby allowing the veneer to retain its natural appearance.

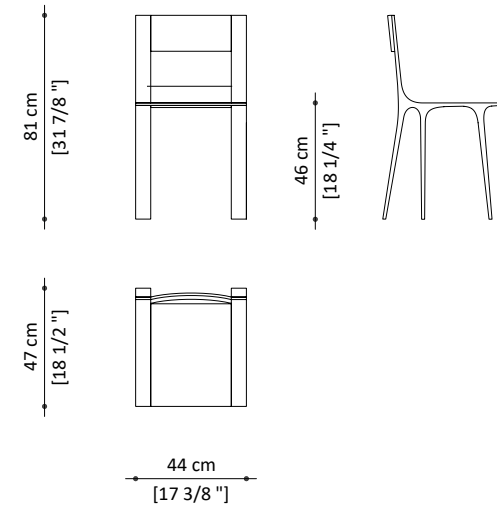

THEO CHAIR BLEACHED | SED.THEO.700
Solid wood frame - bleached ash

GREENKISS

PAOLOCASTELLI

Divani Sofas

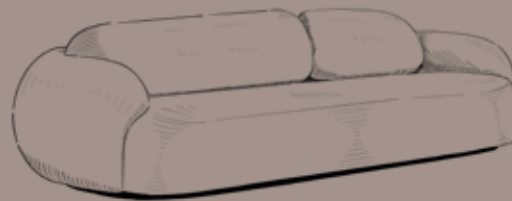

GREENKISS

Vao 380 Sofa



Wood
Ashwood with
acetic finish



Fabric
Wool Bouclé
Col. 03 Linen

Divano a tre posti dalla forma sinuosa e dimensioni generose, poggia su una struttura con gambe realizzate in frassino massello ecosostenibile non selezionato, con finitura acetica, le cui imperfezioni assumono un'evidenza estetica preponderante. Imbottitura realizzata con gomme biologiche autoestinguenti, cuffia in ovatta naturale e cinghie in iuta. Rivestimento non sfoderabile in lana bouclé, tessuto misto lino o lino.

Pouf dalla forma rotondeggiante, poggia su una struttura con gambe realizzate in frassino massello ecosostenibile non selezionato, con finitura acetica, le cui imperfezioni assumono un'evidenza estetica preponderante. Imbottitura realizzata con gomme biologiche autoestinguenti, cuffia in ovatta naturale e cinghie in iuta. Rivestimento non sfoderabile in lana bouclé, tessuto misto lino o lino.

Three-seat sofa with a sinuous shape and ample dimensions, supported by a structure with legs made of discarded eco-friendly solid ash with acetic finish, whose imperfections give it a striking aesthetic appearance. Padding made with eco-friendly and self-extinguishing rubber, batting made of natural wadding, and straps made of jute. Upholstered with natural bouclé wool, linen-blended fabric or linen. This upholstery cannot be removed.

Pouf with well-rounded lines, with legs made of discarded eco-friendly solid ash with acetic finish, whose imperfections give it a striking aesthetic appearance. Padding made with eco-friendly and self-extinguishing rubber, batting made of natural wadding, and straps made of jute. Unremovable covering made of bouclé wool or linen-blended fabric.

SOFA 380

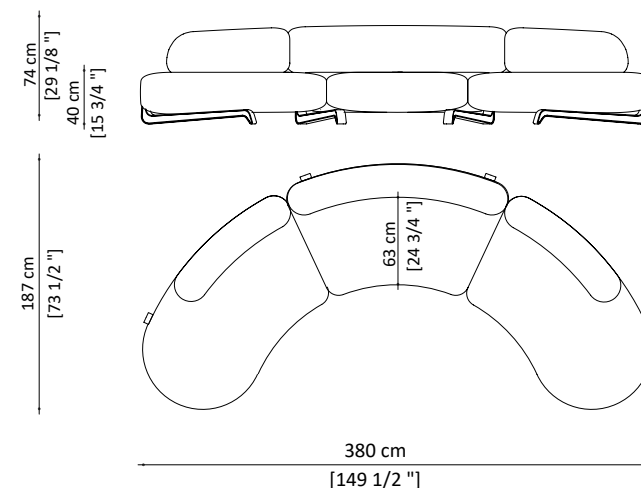

BLENDED LINEN / LINEN | SED.VAOS.110.SUP

Basement in ash wood with acetic finish - Covered in blended linen or linen fabric

WOOL | SED.VAOS.110.DEL

Basement in ash wood with acetic finish - Covered in bouclé wool fabric

POUF

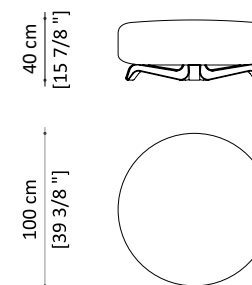

BLENDED LINEN / LINEN | SED.VA00.500.SUP

Basement in ash wood with acetic finish - Covered in blended linen or linen fabric

WOOL | SED.VA00.500.DEL

Basement in ash wood with acetic finish - Covered in bouclé wool fabric

GREENKISS

Vao 250 Sofa



Wood
Ashwood with
acetic finish



Fabric
Wool Bouclé
Col. 03 Linen

Divanetto dalle forme rotondeggianti, poggia su una struttura con gambe realizzate in frassino tinto noce, derivante dalla filiera del legno ecosostenibile, le cui imperfezioni assumono un'evidenza estetica preponderante. Su richiesta la struttura può essere arricchita da un inserto decorativo in tessuto realizzato con fibra di foglie di banana.

Imbottitura realizzata con gomma biologiche e autoestinguenti, cuffia in ovatta naturale e cinghie elastiche in iuta. Rivestimento non sfoderabile in lana bouclé, tessuto misto lino o lino.

Sofa with well-rounded lines supported by a structure with legs made of discarded eco-friendly solid ash with acetic finish, whose imperfections give it a striking aesthetic appearance. On request the structure features a decorative fabric insert made of banana leaf fibre. Padding made with eco-friendly and self-extinguishing rubber, batting made of natural wadding, and straps made of jute. Upholstered with natural bouclé wool, linen-blended fabric or linen. This upholstery cannot be removed.

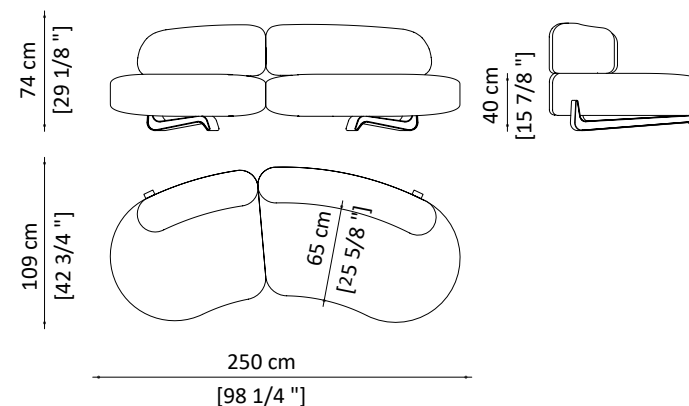

BLENDED LINEN / LINEN | SED.VAOS.120.SUP

Basement in ash wood with acetic finish - Covered in blended linen or linen fabric

WOOL | SED.VAOS.120.DEL

Basement in ash wood with acetic finish - Covered in bouclé wool fabric

GREENKISS
Coral
 Sofa



Fabric
 Wool Bouclé
 Col. 03 Linen



Wood
 Ashwood with
 acetic finish

Forme generose ed abbondanti per una serie di imbottiti il cui disegno riprende la morbidezza di una nuvola. La struttura monolitica non pesa all'occhio, grazie all'inusuale partizione degli elementi che compongono le forme: schienale, braccioli, seduta, che sembrano tra loro incastonati come elementi naturali plasmati dal tempo.

Divano 3 posti con imbottitura realizzata in gomme biologiche autoestinguenti, cuffia in ovatta naturale e cinghie in juta. Rivestimento non sfoderabile in lana bouclé, tessuto misto lino o lino. Base in frassino massello ecosostenibile non selezionato, con finitura acetica.

Generous and abundant shapes for a series of upholstered furniture items with a design that brings cloud-like softness to mind. The monolithic structure is far from heavy on the eye, thanks to the unusual partitioning of the individual elements that make up the whole: backrest, armrests and seat, which seem to fit together like natural elements fashioned by time.

Three-seater sofa with cushioning made of self-extinguishing organic foam rubber covered with natural wadding, and jute webbing. Upholstered with natural bouclé wool, linen-blended fabric or linen. This upholstery cannot be removed. Wood basement in ashwood with acetic finish.

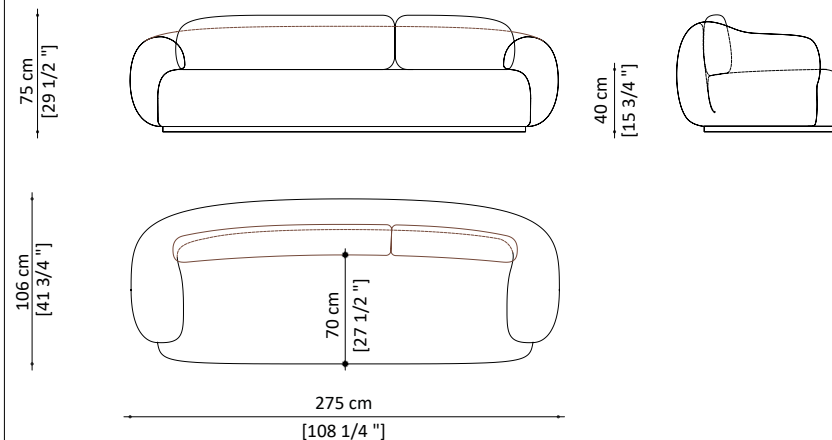

BLENDED LINEN / LINEN | SED.CORA.100.SUP
 Solid wood basement - Covered in blended linen or linen fabric

WOOL | SED.CORA.100.DEL
 Solid wood basement - Covered in bouclé wool fabric

GREENKISS



PAOLO CASTELLI

Poltrone Armchairs

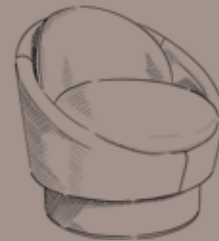
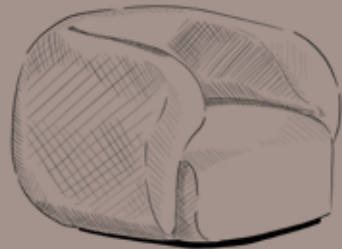

GREENKISS

Vao Armchair

C



Wood
Ashwood with
acetic finish



Fabric
Wool Bouclé
Col. 03 Linen

Poltrona dalla forma rotondeggiante, con gambe realizzate in frassino massello ecosostenibile non selezionato, con finitura acetica, le cui imperfezioni assumono un'evidenza estetica preponderante. Imbottitura realizzata con gomme biologiche e autoestinguenti, cuffia in ovatta naturale e cinghie elastiche in iuta. Rivestimento non sfoderabile in lana bouclé, tessuto misto lino o lino.

Armchair and pouf with well-rounded lines, with legs made of discarded eco-friendly solid ash with acetic finish, whose imperfections give it a striking aesthetic appearance. Padding made with eco-friendly and self-extinguishing rubber, batting made of natural wadding, and straps made of jute. Upholstered with natural bouclé wool, linen-blended fabric or linen. This upholstery cannot be removed.

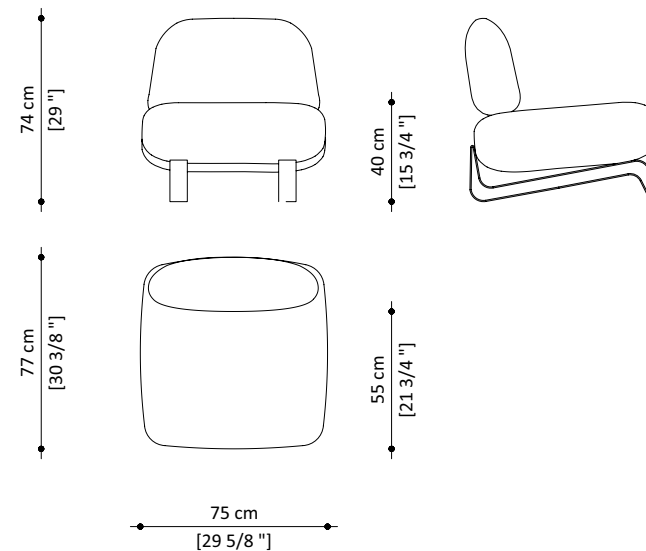

BLENDED LINEN / LINEN | SED.VAOA.200.SUP

Basement in ash wood with acetic finish - Covered in blended linen or linen fabric

WOOL | SED.VAOA.200.DEL

Basement in ash wood with acetic finish - Covered in bouclé wool fabric

GREENKISS

Coral Armchair



Fabric
Wool Bouclé
Col. 03 Linen



Wood
Ashwood with
acetic finish

Forme generose ed abbondanti per una serie di imbottiti il cui disegno riprende la morbidezza di una nuvola. La struttura monolitica non pesa all'occhio, grazie all'inusuale partizione degli elementi che compongono le forme: schienale, braccioli, seduta, che sembrano tra loro incastonati come elementi naturali plasmati dal tempo.

Poltrona compatta, con imbottitura realizzata in gomme biologiche autoestinguenti, cuffia in ovatta naturale e cinghie in juta. Rivestimento non sfoderabile in lana bouclé, tessuto misto lino o lino. Base in frassino massello ecosostenibile non selezionato, con finitura acetica.

Generous and abundant shapes for a series of upholstered furniture items with a design that brings cloud-like softness to mind. The monolithic structure is far from heavy on the eye, thanks to the unusual partitioning of the individual elements that make up the whole: backrest, armrests and seat, which seem to fit together like natural elements fashioned by time.

A compact armchair with cushioning made of self-extinguishing organic foam rubber covered with natural wadding, and jute webbing. Upholstered with natural bouclé wool, linen-blended fabric or linen. This upholstery cannot be removed. Wood basement in ashwood with acetic finish.

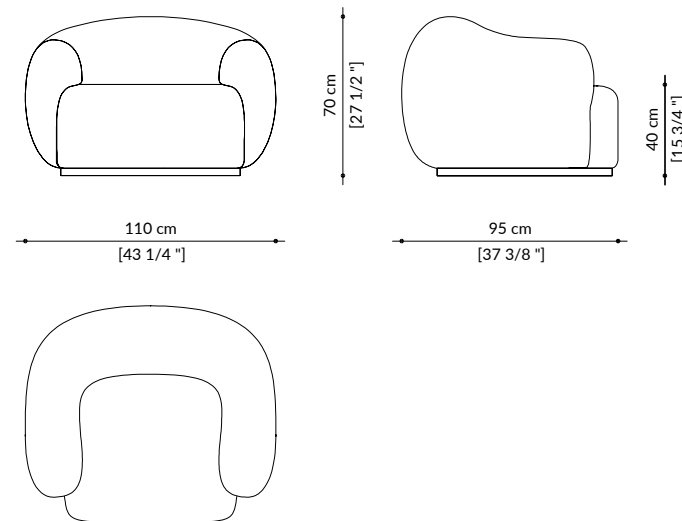

BLENDED LINEN / LINEN | SED.CORA.200.SUP

Solid ashwood basement with acetic finish - Covered in blended linen or linen fabric

WOOL | SED.CORA.200.DEL

Solid wood basement - Covered in bouclé wool fabric

GREENKISS

Luna Armchair

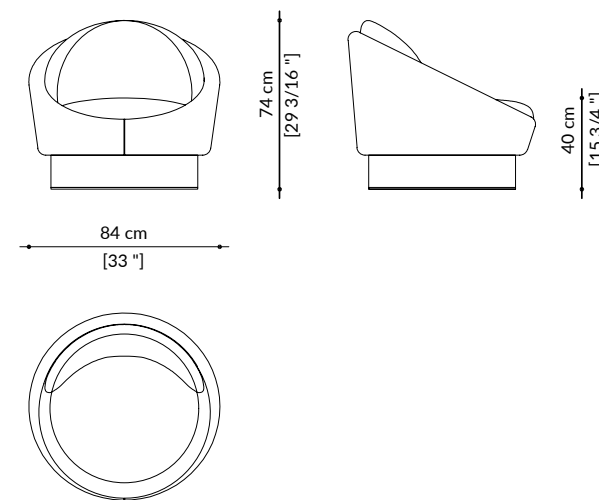

**Metal Finish
Champagne
Matt**

**Blended
Lined
Col. 406 Lined**

**Econabuck
Col. 604 Taupe**

Deliziosa poltroncina a pozzetto dalle forme sofisticate e contemporanee, ha una struttura in legno di frassino ecosostenibile non selezionato, con imbottitura realizzata in gomme biologiche autoestinguenti, cuffia in ovatta naturale e cinghie in juta. Lo schienale imbottito si avvolge come un petalo innestandosi sul sedile.

Rivestimento non sfoderabile in lana bouclé, lino o tessuto misto lino con dettagli in metallo color champagne a satinatura orbitale. La struttura poggia su un zoccolo rivestito in tessuto. Dettaglio base in metallo color champagne a satinatura orbitale.

Delightful tub chair with a sophisticated contemporary shape. The structure is made of discarded eco-friendly ash wood, with cushioning made of self-extinguishing organic foam rubber covered with natural wadding, and jute webbing. The cushioned backrest wraps around the seat like a petal, adorning it with three contrasting decorations.

Upholstered with natural bouclé wool, linen or blended linen fabric with metal details col. champagne orbital matt. This upholstery cannot be removed. The structure rests on a base with plinth clad in econabuck or champagne-coloured metal plate with an orbital satin finish.

BLENDEN LINEN / LINEN | SED.LUNA.200.SUP

Base covered in econabuck
Upholstering in blended linen or linen fabric

WOOL | SED.LUNA.200.DEL

Base covered in econabuck
Upholstering in bouclé wool fabric

GREENKISS



PAOLO CASTELLI

Contenitori Storage



GREENKISS

Selima Tv cabinet

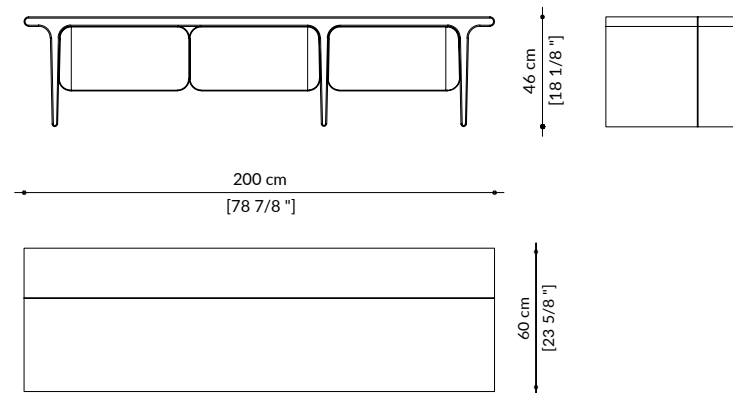

Alternative wood options



Metal Finish
Champagne
Matt

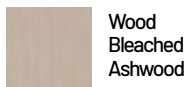

Wood
Bleached
Ashwood



Fabric Hemp
fiber Col.
Turquoise
100% organic



Wood
Walnut Stained
Ashwood



Wood
Ashwood with
acetic finish

Mobile contenitore con struttura e ante in frassino ecosostenibile non selezionato, disponibile in tre versioni: con finitura acetica, sbiancata o tinto noce con finitura poro aperto. Con questo procedimento il poro del legno viene volutamente lasciato aperto permettendo all'essenza di mantenere il suo aspetto naturale.

La struttura è impreziosita da un inserto metallico color champagne opaco. Ante rivestite in tessuto turchese 100% naturale, realizzato in fibra di canapa nepalese.

Storage unit made of solid eco-friendly ash discarded, available in three options: natural ash with acetic finish, bleached or walnut-stained version with open pore finish. By this process the wood pores are deliberately left open, thereby allowing the veneer to retain its natural appearance. Frame is embellished with matt champagne-coloured metal inserts. Doors lined with turquoise fabric 100% natural, made of Nepalese hemp fibre.

SELIMA TV CABINET | LIB.SELI.120

Nepalese hemp fibre covering col. turquoise (doors)
Metal details champagne orbital satin finished - Solid wood frame
Available wood finishes: walnut stained ash - bleached ash - acetic finish

GREENKISS

Lina Cabinet

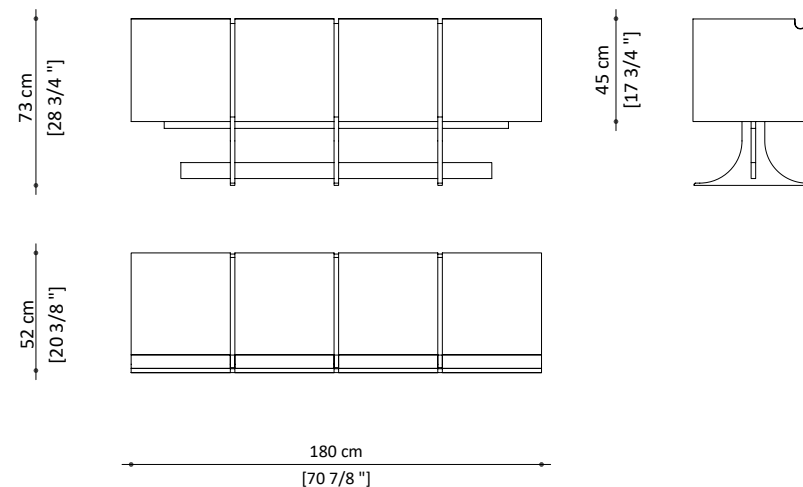

Vicenza Stone
Col. Light Grey
Sandblasted



Wood
Bleached
Ashwood



Metal Finish
Champagne
Orbital

Alternative wood options



Wood Walnut
Stained
Ashwood



Wood Ashwood
with acetic
finish

Mobile contenitore con struttura e ante in frassino ecosostenibile non selezionato, disponibile in tre versioni: con finitura acetica, sbiancata o tinto noce con finitura poro aperto. Con questo procedimento il poro del legno viene volutamente lasciato aperto permettendo all'essenza di mantenere il suo aspetto naturale.

Il basamento e le maniglie sono in metallo finitura color champagne a satinatura orbitale. Il top è realizzato in pietra di Vicenza grigia sabbata caratterizzata dalla presenza di macrofossili.

Storage unit with frame and doors solid eco-friendly ash discarded, available in three options: natural ash with acetic finish, bleached or walnut-stained version with open pore finish.

By this process the wood pores are deliberately left open, thereby allowing the veneer to retain its natural appearance.

The metal base and handles have a champagne-coloured orbital satin finish. The top is made of Vicenza stone Col. Light Grey sandblasted with macrofossils.

LINA CABINET | LIB.LINA.110

Top made in Vicenza stone Col. Light Grey sandblasted
Metal structure champagne orbital satin finished - Solid wood frame
Available wood finishes: walnut stained ash - bleached ash - acetic finish

GREENKISS

Selima

Bedside table



Metal Finish
Champagne
Orbital



Wood
Walnut Stained
Ashwood

Alternative wood options



Wood
Ashwood with
acetic finish



Wood
Bleached
Ashwood

Comodino dai bordi arrotondati con struttura a un cassetto realizzata in massello di frassino ecosostenibile, disponibile in tre versioni: con finitura acetica, sbiancata o tinto noce con finitura poro aperto. Con questo procedimento il poro del legno viene volutamente lasciato aperto permettendo all'essenza di mantenere il suo aspetto naturale. Inserto sul piano col. champagne opaco. Il cassetto presenta su un'elegante maniglia a gola. Disponibile con gambe costituite da lamiera in metallo finitura col. champagne piegata a disegno o con gambe in legno abbinata alla struttura con inserto in metallo color champagne opaco.

Single drawer bedside table with rounded edges, made of solid eco-friendly ash wood, available in three versions: with an acetic, bleached or walnut-stained open-pore finish. This process deliberately leaves the pores of the wood open, allowing it to retain its natural appearance. Matt champagne-coloured insert on top. The drawer has an elegant groove handle. Available with legs made of sheet metal shaped to design with champagne-coloured finish, or with wooden legs matching the structure, with a matt champagne-coloured metal insert.

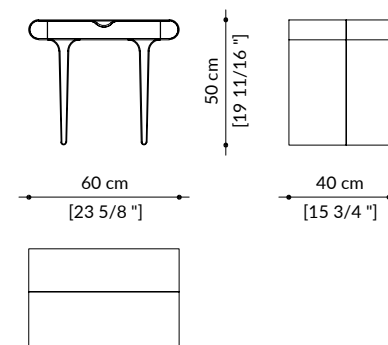

WOOD | LIB.SELI.210

Solid wood frame with one drawer

Available wood finishes: walnut stained ash - bleached ash - acetic finish

METAL | LIB.SELI.220

Metal structure champagne orbital satin finished - Solid wood top and drawer

Available wood finishes: walnut stained ash - bleached ash - acetic finish

GREENKISS



PAOLO CASTELLI

Letti Beds

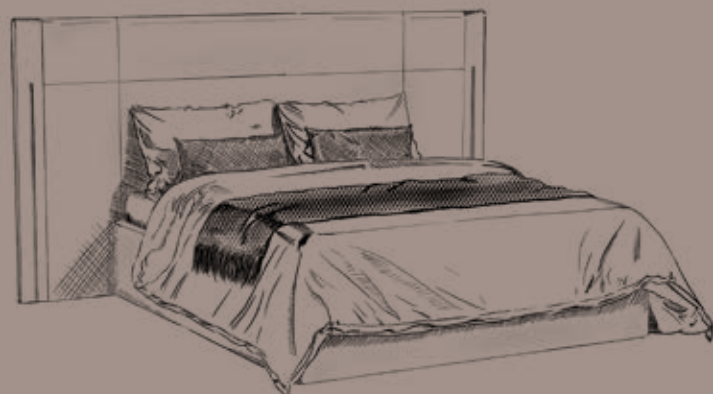

GREENKISS

Astra Bed



Alternative wood options



Elegante letto con testata alta, realizzata interamente in massello di frassino ecosostenibile, disponibile in tre versioni: con finitura acetica, sbiancata o tinto noce con finitura poro aperto. Con questo procedimento il poro del legno viene volutamente lasciato aperto permettendo all'essenza di mantenere il suo aspetto naturale. La testata in legno è rivestita in lana bouclé, tessuto misto lino o lino, non sfoderabile. I dettagli laterali della testata sono in metallo color champagne opaco. Il giroletto imbottito rivestito del medesimo tessuto, poggia su piedini cilindrici in legno abbinati alla struttura.

Rete e materasso non inclusi.

Dimensione materasso 180 x 200 cm.

Elegant bed with high headboard, made entirely of solid eco-friendly ash wood, available in three versions: with an acetic, bleached or walnut-stained open-pore finish. This process deliberately leaves the pores of the wood open, allowing it to retain its natural appearance. The headboard is upholstered with natural bouclé wool, linen-blended fabric or linen. This upholstery cannot be removed. The lateral details of the headboard are made of matt champagne-coloured metal. The upholstered bed frame is upholstered with same fabric and supported by cylindrical same wooden feet. Mattress and bedspring not included
Mattress Size: 180x200 cm.

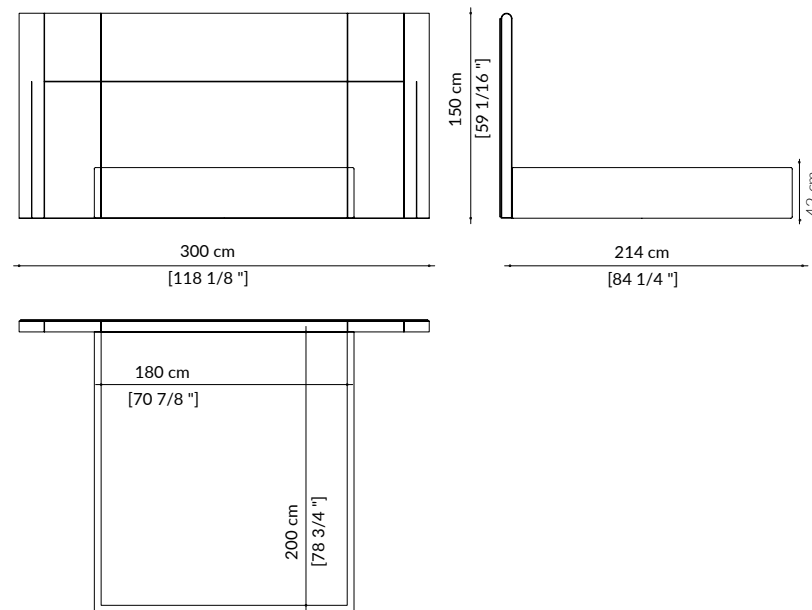

BLENDED LINEN / LINEN | NOT.ASTR.100.SUP

Metal details champagne matt - Solid wood frame - Covered in blended linen or linen fabric
Available wood finishes: walnut stained ash - bleached ash - acetic finish

WOOL | NOT.ASTR.100.DEL

Metal details champagne matt - Solid wood frame - Covered in natural wool
Available wood finishes: walnut stained ash - bleached ash - acetic finish

GREENKISS

PAOLOCASTELLI

Luci Lightings

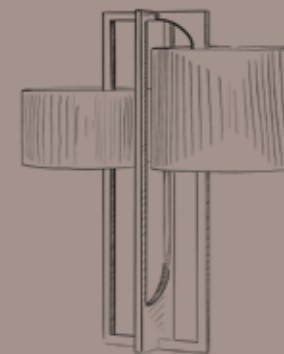
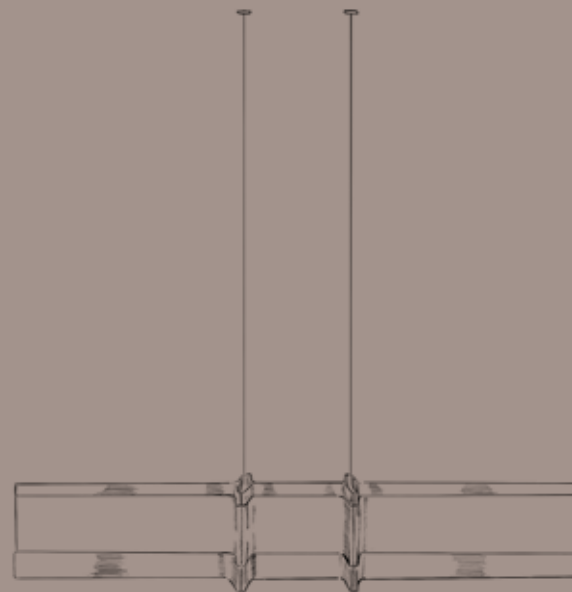
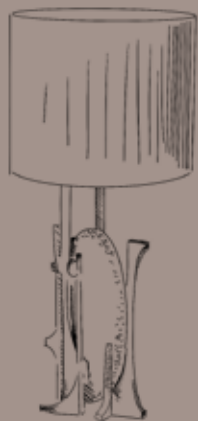

GREENKISS



Astra Suspension Lamp



Wood
Bleached
Ashwood



Metal Finish
Champagne
Orbital



Wood
Walnut Stained
Ashwood



Wood
Ashwood with
acetic finish

Available wood options

Un lampadario dalle forme rigorose e dall'aspetto leggero, è costituito da un'anima centrale in frassino ecosostenibile non selezionato, disponibile in tre versioni: con finitura acetica, sbiancata o tinto noce con finitura poro aperto. Con questo procedimento il poro del legno viene volutamente lasciato aperto permettendo all'essenza di mantenere il suo aspetto naturale. Alle estremità del legno si innestano due fasce metalliche color champagne a satinatura orbitale. Passacavi in metallo color champagne. L'illuminazione, a led, viene uniformata da un diffusore in policarbonato opalino che rende omogenea la diffusione luminosa.

A lamp with a rigorous shape and light appearance, it consists of a central core made of discarded eco-friendly ash, available in three versions: with an acetic, bleached or walnut-stained open-pore finish. This process deliberately leaves the pores of the wood open, allowing it to retain its natural appearance. There are two champagne-coloured orbital satin-finished metal bands at the ends of the wood. Champagne-coloured metal cable guide. The LED lighting is harmonised by an opal diffuser that distributes the light evenly.

L 60

TECHNICAL SHEET ASTRA 60

Light source: Strip LED
Total power: 20W
Strip led power: 17W
Voltage: 220 - 240 V
Rated luminous flux: 1410 Lm
Colour temperature: 2700° K
Colour rendering index: Ra>80
Dimmer function: on request
Cable length: 2m
Weight: 5 Kg

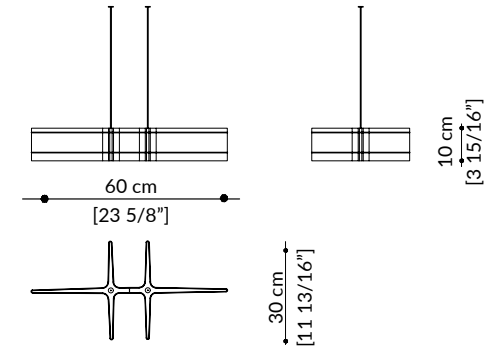

L 60 | ILL.ASTR.220

Metal structure champagne orbital satin finished - Solid wood frame
Available wood finishes: walnut stained ash - bleached ash - acetic finish

L 120

TECHNICAL SHEET ASTRA 120

Light source: Strip LED
Total power: 38W
Strip led power: 33,5W
Voltage: 220 - 240 V
Rated luminous flux: 2790 Lm
Colour temperature: 2700° K
Colour rendering index: Ra>80
Dimmer function: on request
Cable length: 2m
Weight: 10 Kg

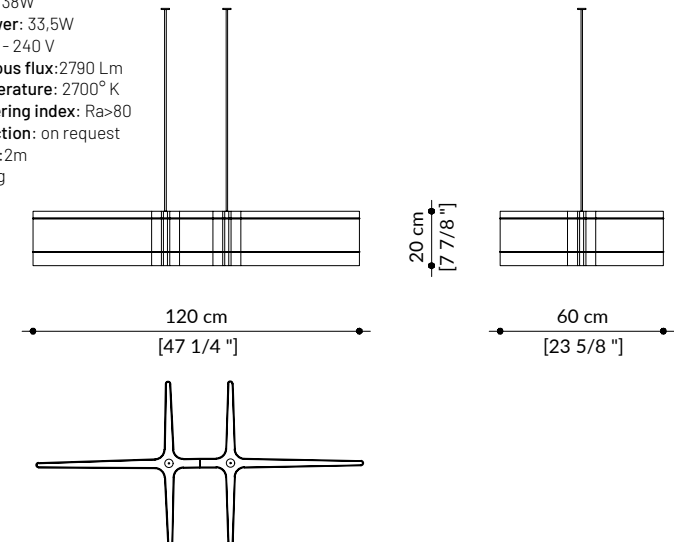

L 120 | ILL.ASTR.210

Metal structure champagne orbital satin finished - Solid wood frame
Available wood finishes: walnut stained ash - bleached ash - acetic finish

GREENKISS

Pablo Lamp

C



Faenza Ceramic
Raw finish
Col. Dark White



Faenza Ceramic
Raw finish
Col. Optical White



Fabric Hemp fiber
Col. Beige
100% organic



Stone
Selenite

Lampada con base dalla forma asimmetrica realizzata in ceramica artigianale di Faenza color bianco in cui si alternano elementi in finitura lucida, con elemento a uovo realizzato in selenite. Il paralume -100% naturale- è realizzato in fibra di canapa nepalese. Sorgente luminosa E27.

Lamp with white handmade Faenza ceramic base with an asymmetrical shape, featuring elements with a high-gloss finish alternating with an egg-shaped element made of selenite. The 100% natural lampshade is made of Nepalese hemp fibre. Lighting source E27 bulb.

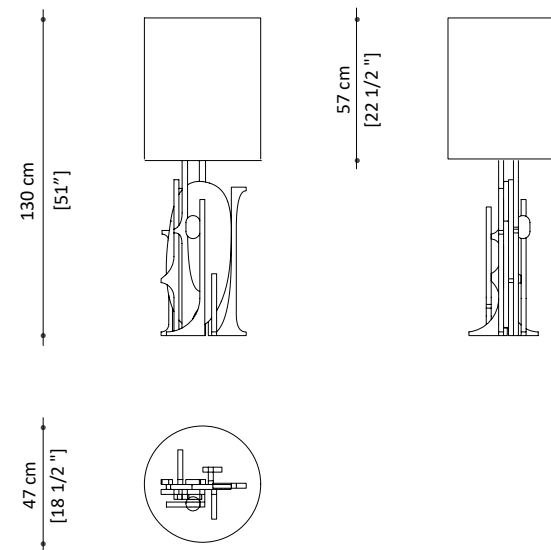

TECHNICAL SHEET

PABLO LAMP

Light source: E27 bulb

Total power: 8W

Voltage: 220 - 240 V

Rated luminous flux: 1055 Lm

Colour temperature: 2700° K

Colour rendering index: Ra>80

Dimmer function: No

Weight: 17 Kg

PABLO LAMP | ILL. PICA.100

Faenza ceramic base - Egg-shaped element made of selenite
Nepalese hemp fibre lampshade

GREENKISS

Hyperbole Lamp



Black antique
granite striped



Fabric
Banana leaf
100% organic

Lampada con base in granito antico nero a texture rigata. Il paralume -100% naturale- è realizzato in fibra di banano e presenta una finitura interna rame satinato opaco. Sorgente luminosa E27.

Lamp with base made of black antique granite striped. The 100% natural lampshade is made of banana leaf fibre and internally coloured copper. Lighting source E27 bulb.

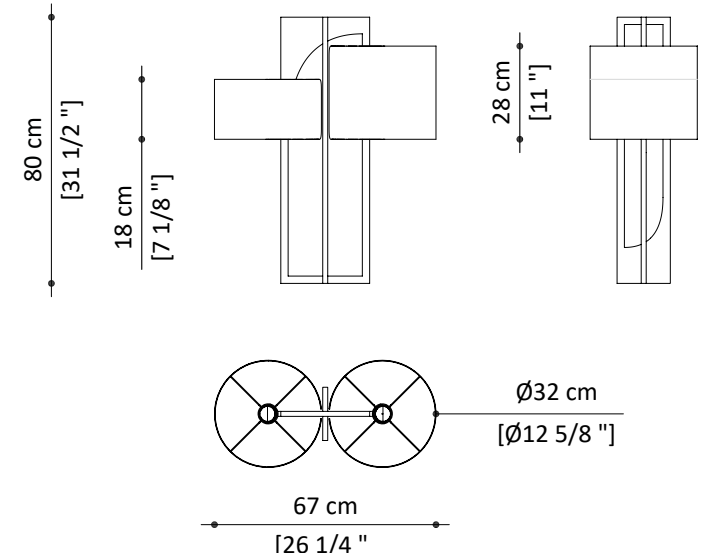

TECHNICAL SHEET

HYPERBOLE LAMP

Light source: 2x E27 bulb

Total power: 17W (2 x 8,5W)

Voltage: 220 - 240 V

Rated luminous flux: 2110 Lm

Colour temperature: 2700° K

Colour rendering index: Ra>80

Dimmer function: no

Weight: 16 Kg

HYPERBOLE LAMP | ILL.HYPE.100

Black antique granite striped structure - 100% natural banana leaf fibre lampshade

GREENKISS

Oscar Lamp

CE



Faenza Ceramic
Raw finish
Col. Optical White



Fabric Hemp fiber
Col. Beige
100% organic

Lampada con base realizzata in ceramica artigianale di Faenza color bianco opaco. Il paralume -100% naturale- è realizzato in fibra di canapa nepalese. Sorgente luminosa E27.

Lamp with base made of matt white handmade Faenza ceramic. The 100% natural lampshade is made of Nepalese hemp fibre. Lighting source E27 bulb.

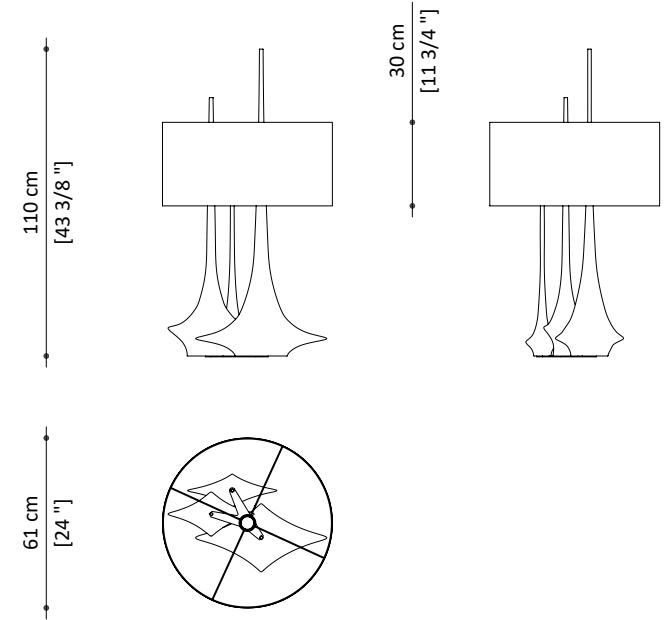

TECHNICAL SHEET

OSCAR LAMP

Light source: E27 bulb

Total power: 8W

Voltage: 220 - 240 V

Rated luminous flux: 1055 Lm

Colour temperature: 2700° K

Colour rendering index: Ra>80

Dimmer function: No

Weight: 6 Kg

OSCAR LAMP | ILL.OSCA.100

Faenza ceramic base - Nepalese hemp fibre lampshade

GREENKISS

Kaala Lamp

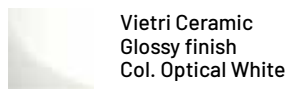

Vietri Ceramic
Glossy finish
Col. Optical White



Vietri Ceramic
Glossy finish
Col. Yellow



Metal Finish
Champagne
Matt



Fabric Hemp fiber
Col. Beige
100% organic



Fabric Hemp fiber
Col. Turquoise
100% organic

Lampada con base in metallo color champagne opaco, ricoperto da lastre realizzate in ceramica artigianale di Vietri smaltata bianca o gialla. L'accostamento dei due materiali crea un elegante inserto metallico. Il paralume -100% naturale- è realizzato in fibra di canapa nepalese color verde o giallo. Sorgente luminosa E27.

Lamp with structure made in matt champagne-coloured metal, covered by handmade white or yellow-glazed Vietri ceramic. The combination of two materials creates an elegant metal trim. The 100% natural lampshade is made of Nepalese hemp fibre, green or white. Lighting source E27 bulb.

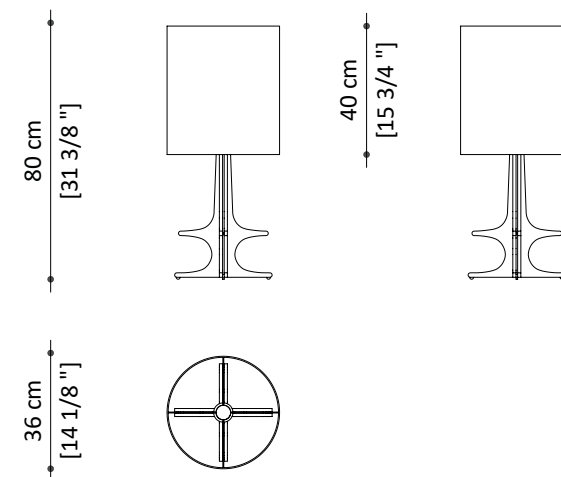

TECHNICAL SHEET

KAALA LAMP

Light source: E27 bulb

Total power: 8,5W

Voltage: 220 - 240 V

Rated luminous flux: 1055 Lm

Colour temperature: 2700° K

Colour rendering index: Ra>80

Dimmer function: no

Weight: 6,5 Kg

KAALA LAMP | ILL.KAAL.100

Vietri ceramic base - yellow or white - Nepalese hemp fibre lampshade

STANDARD SALES TERMS AND CONDITIONS

General Provisions

a) The Standard Sales Terms and Conditions (hereinafter referred to as the "Standard Terms and Conditions") form an integral part of the agreements entered into between Paolo Castelli S.p.a. (hereinafter referred to as "Paolo Castelli") and the Purchaser for the supply of products supplied and/or distributed by the above mentioned company (hereinafter the "Products").

(b) The Standard Terms and Conditions apply to all transactions entered into between Paolo Castelli and the Purchaser whether or not expressly referenced therein. Any terms or conditions different from those provided herein shall only take effect if confirmed in writing by Paolo Castelli. Paolo Castelli reserves the right to modify, supplement or amend the Standard Terms and Conditions, by attaching such changes to quotations or any written correspondence.

Quotations and orders

Customer's acceptance of the quotations submitted by Paolo Castelli - upon receipt of 50% deposit - is binding on the Customer and irrevocable. Upon receipt of such acceptance, Paolo Castelli will send the Customer an order confirmation expressly stating delivery method and the technical information necessary to deliver the goods (e.g. delivery addresses, delivery to the floor, time, contact persons and telephone number). Any quotations submitted by agents shall only be deemed to be valid and effective after they are confirmed in writing by Paolo Castelli. Any changes to or requests and integrations to quotations by agents or Customers shall be made in writing, and shall require a written confirmation by Paolo Castelli. Paolo Castelli disclaims any and all liabilities for possible errors or misunderstandings arising in connection with changes to orders placed verbally or over the telephone.

Prices and Payment Terms

Product Prices do not include VAT, which must be paid according to specific indications provided in the invoice.

Taxes, duties, shipping, insurance, installation and after-sales service are not included in the prices, unless quoted separately.

In addition to the other remedies allowed by applicable law or these General Terms and Conditions, Paolo Castelli reserves the right to charge late payment interests at the official interest rate set by the European Central Bank plus seven (7) points as of the day payment was due. Payments shall be made as follows: 50% down payment when quotation is signed; 50% balance shall be paid before Products are shipped. Any other conditions agreed upon shall require the written form. In the event of default or late payment after the term indicated by Paolo Castelli, even in part or limited to one price instalment, Paolo Castelli shall be entitled to terminate the agreement without further notice. All amounts paid up to that time shall be withheld by way of damage compensation.

Changes to orders

Any requests of changes deviating from the content of order confirmation may only be accepted if compatible with the production process and/or the process under way. If accepted, they may give rise to extra charges incurred in making such changes.

Orders - Customer's default

It is hereby expressly agreed that the Customer may not unilaterally terminate the order and/or the agreement. In the event after confirming an order Paolo Castelli becomes aware of detrimental events affecting the Purchaser such as protests, seizures, attachment, or it becomes known that the Purchaser is in financial difficulties, Paolo Castelli may, at its discretion, suspend order fulfilment and demand special guarantees, or terminate the agreement on grounds of Purchaser default under art. 1456 of the Italian Civil Code by written notice via registered mail with advice of receipt, fax or CEM.

Delivery and Delivery Terms

Unless otherwise agreed, delivery is ex works at Customer's risk. Notwithstanding the above, Paolo Castelli may charge an additional shipping fee to Customer on invoice. Partial deliveries are only allowed when agreed upon between the parties and any extra costs shall be borne by Customer. The delivery times indicated by Paolo Castelli are not binding and are computed in working days starting from receipt of the first down payment. In the event delivery is postponed through fault of the Customer and the Product needs to be kept in stock for more than 5 days after the agreed delivery date, any relating costs shall be charged to Customer and Paolo Castelli shall not be liable for any damage to and/or deterioration of the Product. Unless otherwise agreed, downloading and delivery to floor are at the Customer's expense. For any events outside the control of Paolo Castelli, such as orders of authorities, shortage of raw materials, riots of any kind and other force majeure events, Paolo Castelli shall deem itself to not be bound to any terms or commitments for the duration of the adverse event.

Installation

At Customer's request, installation may be performed by personnel appointed by Paolo Castelli, and any costs incurred for installers and the assistance of skilled personnel shall be at Customer's charge. Installation does not include any masonry work, plant installation, or any other work not expressly specified on order or anyway outside the scope of the supply.

Customer shall make available a suitable storage room for products and equipment. Paolo Castelli shall not be liable for faults or breakdown occurring during installation.

Responsibility:

Paolo Castelli does not respond to any damage to person or property caused by the incorrect installation of its lighting fixtures and furniture.

Warranty

It is the Customer's responsibility to check product compliance at the time of receipt and anyway before commissioning. Unless Customer claims a defect and informs the seller within eight days from discovering such defect, Customer's rights under applicable law shall become null and void. Failure to comply with payment terms and conditions on the part of the Purchaser shall make the warranty null and void.

Retention of title

Pursuant to articles 1523 and 1524 of the Italian Civil Code, the parties agree that the sales transaction is subject to retention of title in favour of the seller. The parties agree that the ownership of the Product is transferred to the Customer at the time the full price is settled, whereas possession and the associated risk to the Purchaser is transferred at the time the product is shipped to Customer. Court of jurisdiction

The agreement is governed by Italian law. Any dispute concerning the construction or performance of agreements between the parties shall be submitted to the Court of Bologna, that shall have sole jurisdiction.



PAOLO CASTELLI

La descrizione e le immagini dei prodotti del presente catalogo sono puramente indicative e non possono essere considerate vincolanti ai fini del loro utilizzo. Paolo Castelli S.p.A. si riserva di apportare ai prodotti le modifiche che ritiene più opportune, in qualsiasi momento e senza preavviso. I prodotti, di natura artigianale, possono presentare artefatti materici o irregolarità di lavorazione. Tali irregolarità sono da considerarsi parte integrante della struttura del prodotto stesso e garanzia della lavorazione interamente artigianale. Per ulteriori informazioni sulle caratteristiche tecniche dei prodotti, invitiamo a consultare il sito www.paolocastelli.com dove troverete l'elenco dei contatti a cui rivolgervi.

Descriptions and pictures of the products included in the present catalogue are purely indicative and cannot be considered binding for their final use. Paolo Castelli S.p.A. reserves itself the right to modify its own products without any prior notification. The handmade artisan production can present irregularities due to the manufacturing. These irregularities must be considered essential part of the product itself and guarantee of entirely handcrafted manufacturing. For any further technical information on the products, please visit www.paolocastelli.com where you can find all the contacts you can address to.



PAOLO CASTELLI

BOLOGNA

Contract Office & Showroom

MILAN

Contract Office & Showroom

PARIS

Contract Office & Showroom

LONDON

Contract Office

CARRARA

Marine Division

HEADQUARTER VIA 1° MAGGIO, 93 | 40064 OZZANO DELL'EMILIA | BOLOGNA - ITALY | TEL. +39 051 4695511 | info@paolocastellispa.com | www.paolocastelli.com