

Inspiration
THE HOUSE OF ELEGANCE

PAOLO CASTELLI

THE RANGE

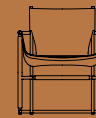
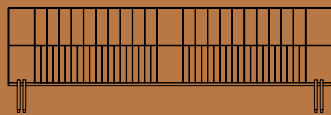
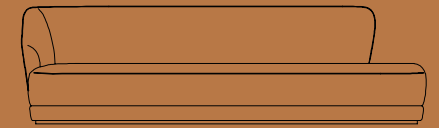
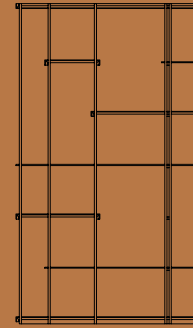
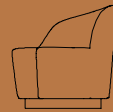
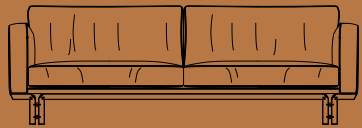

FINE FURNITURE & LIGHTING

TAVOLI TABLES	p. 5
SEDUTE SEATING	p. 71
DIVANI SOFAS	p. 92
POLTRONE ARMCHAIRS	p. 137
LIBRERIE e CONTENITORI BOOKCASES & STORAGE	p. 161
LETTI BED	p. 202
COMPLEMENTI COMPLEMENTS	p. 217
LUCI LIGHTING	p. 247

TAVOLI
TABLES

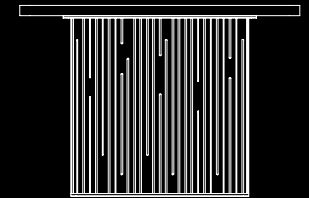
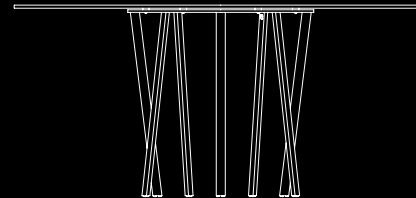
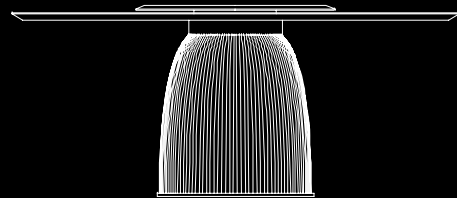
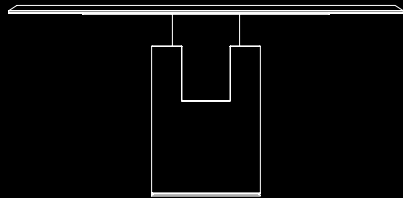

Inspiration

ALBA TABLE

DESIGN | VITTORIO PARADISO



Metal Finish
Bronze
Shadow Matt



Vicenza Stone
Col. Ivory
Honed



Bovine Leather
Col. 634 Oasi

Una miscela di materiali naturali, la pietra vicentina levigata color avorio, e industriali, il bronzo nella finitura shadow opaco, si fondono in un prodotto unico dalle forme geometriche e razionali. Un cerchio e un cilindro, che accostati fra loro formano un unico elemento di grande personalità e dal forte segno grafico in cui la forza espressiva dei materiali esalta le singole lavorazioni.

Il piano presenta al centro una decorazione circolare a bassorilievo, segno della mano degli artigiani che compongono la bellezza di finiture mai banali. Estremamente particolare la giunzione tra la base e il top del tavolo che genera un gradevole ed elegante dettaglio tecnico/estetico.

Disponibile anche la versione con base in legno rivestita in pelle col. 634 Oasi.

A combination of natural and industrial materials, Vicenza stone honed col. Ivory and bronze in a matt shadow finish respectively, come together to create a unique product featuring geometrical and rational shapes. A circle and a cylinder, coupled to form a single element characterised by outstanding personality and a strong graphic sign in which the expressive strength of the materials emphasises the individual processes. The centre of the table features a circular bas-relief decoration, a symbol of the skill of the craftsmen who create the most remarkably beautiful finishes. The joint between the base and the top of the table is extremely remarkable, generating a detail that is elegantly pleasing both technically and aesthetically. Also available model with wooden basement covered in leather, col. 634 Oasi.



ROUND
Ø 160
Ø 180

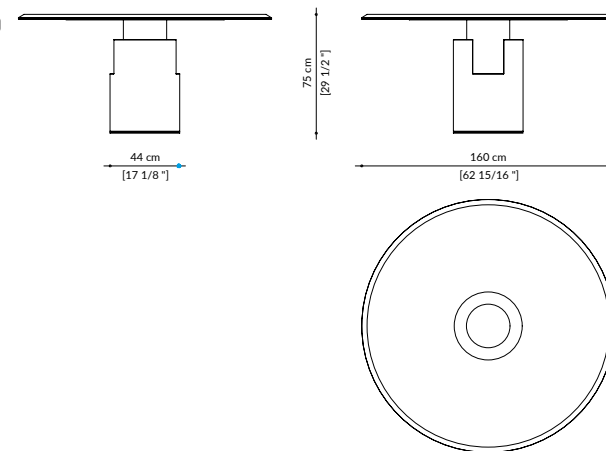

Ø 160 LEATHER | TAV.ALBA.310

Top Vicenza stone col. Ivory honed
Base in metal finish bronze shadow mat, covered with leather col. 634 Oasi

Ø 160 STONE | TAV.ALBA.311

Top Vicenza stone col. Ivory honed
Base in metal finish bronze shadow mat, covered with Vicenza stone col. Ivory honed

Ø 180 LEATHER | TAV.ALBA.320

Top Vicenza stone col. Ivory honed
Base in metal finish bronze shadow mat, covered with leather col. 634 Oasi

Ø 180 STONE | TAV.ALBA.321

Top Vicenza stone col. Ivory honed
Base in metal finish bronze shadow mat, covered with Vicenza stone col. Ivory honed

RECTANGULAR

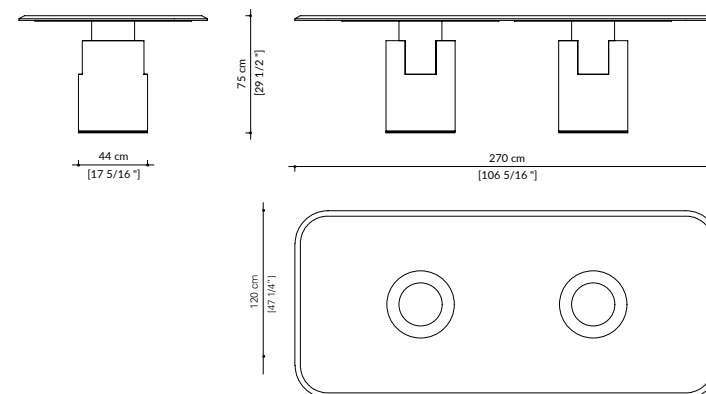

RECTANGULAR LEATHER | TAV.ALBA.330

Top Vicenza stone col. Ivory honed
Base in metal finish bronze shadow mat, covered with leather col. 634 Oasi

RECTANGULAR STONE | TAV.ALBA.331

Top Vicenza stone col. Ivory honed
Base in metal finish bronze shadow mat, covered with Vicenza stone



◀ **Pietra Vicentina: pietra antica con macrofossili.**

Pietra Vicentina: antique stone with macro-fossil.

NETTUNO TABLE

DESIGN | VITTORIO PARADISO



Alternative base options



Marble
Noir Saint
Laurent striped



Wood
Eucalyptus



Metal Finish
Black Nickel
Matt striped

Tavolo dalla spiccata personalità con struttura in metallo con finitura oro satinato opaco e rivestimento base in marmo Noir Saint Laurent lucido a coste - fresatura cnc (a controllo numerico), top in legno di eucalipto con bordatura in metallo con finitura nichel nero satinato opaco impreziosito da dettagli in finitura oro satinato opaco. Disponibile anche con base in metallo finitura nichel nero opaco.

Disponibile nel formato tondo con diametro 180 cm e rettangolare 250 x 110 cm.

A table with a distinct personality featuring a metal structure finished in matt satin gold and a base covered in glossy ribbed cnc (numerically controlled) milled Noir Saint Laurent marble, a top in eucalyptus wood with metal edging with a matt black satin nickel finish embellished with details in matt satin finish gold. Also available with black nickel metal base.

Available as a round table with a 180 cm diameter and rectangular 250 x 110 cm.

ROUND

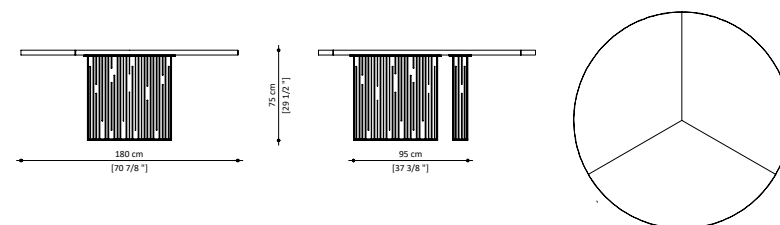

Ø 180 METAL | TAV.NETT.321

Eucalyptus wood top - Metal structure black nichel matt - Metal cnc base

Ø 180 MARBLE | TAV.NETT.320

Eucalyptus wood top - Marble Noir Saint Laurent striped

RECTANGULAR

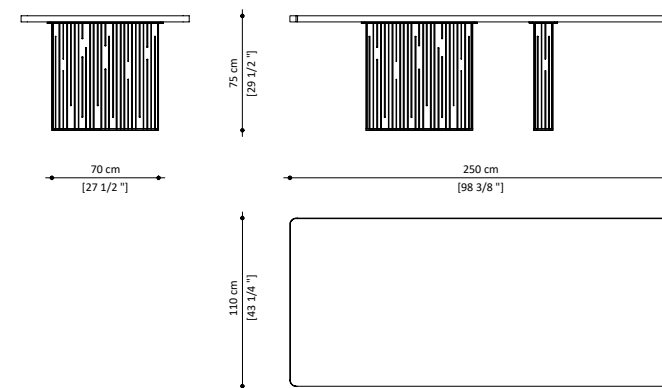

RECTANGULAR METAL | TAV.NETT.301

Eucalyptus wood top - Metal structure black nichel matt - Metal cnc base

RECTANGULAR MARBLE | TAV.NETT.300

Eucalyptus wood top - Marble Noir Saint Laurent striped



C

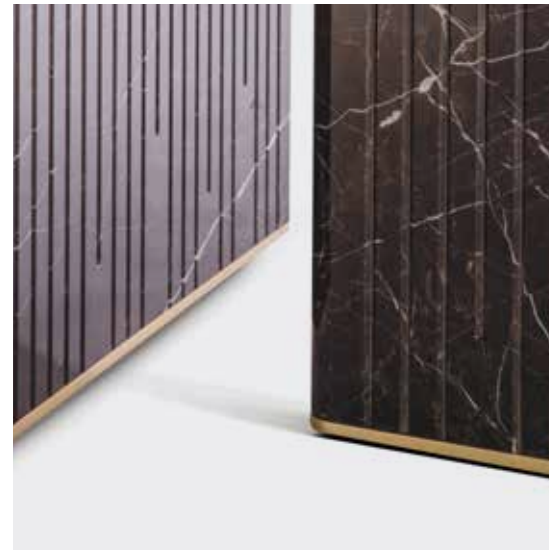

▲
Legno di eucalipto: essenza dalle suggestive venature grigiastre di varie gradazioni.

Eucalyptus wood: wood with grey scaled veining.

Inspiration



LEAF TABLE

DESIGN | PAOLO CASTELLI



Metal Finish
Matt Gold



Glass
Grey
Brown



Resin Concrete
Handcrafted

Un tavolo rotondo dalle dimensioni generose, caratterizzato da una base circolare in metallo, finitura oro satinato opaco, piedistallo decorativo in resina-cemento decorata a mano - finitura brunita, con dettagli in finitura oro opaco, top lucido in vetro retrolaccato RAL 8019 marrone grigiastro, con bordatura metallica finitura oro opaco.

A round table of generous proportions, featuring a circular metal base with a matt satin gold finish, a decorative concrete resin pedestal with a hand-painted surface - a burnished finish, with matt gold details, a glossy top of RAL 8019 grey brown back-lacquered glass, with matt gold finish metal edging.

Ø 160
Ø 180

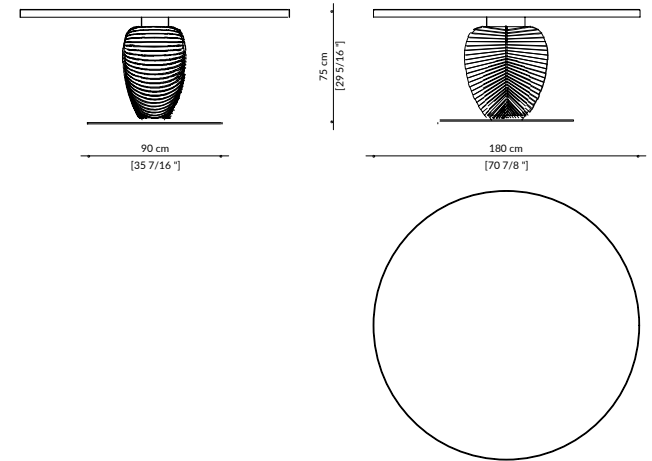

Ø160 | TAV.LEAF.310

Circular metal base, matt satin gold finished - decorative resin concrete pedestal
Glossy back-lacquered RAL 8019 grey brown glass top

Ø180 | TAV.LEAF.300

Circular metal base, matt satin gold finished - decorative concrete pedestal
Glossy back-lacquered RAL 8019 grey brown glass top

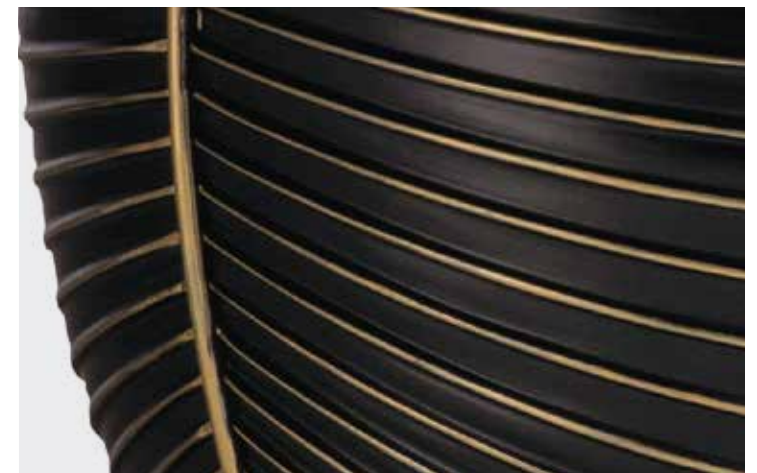



Inspiration



DIONE TABLE

DESIGN | PAOLO CASTELLI

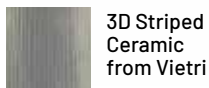

3D Striped
Ceramic
from Vietri



Marble
Calacatta



Metal Finish
Matt Gold



Matt
Brass



Marble
White Silk
(top alternative)

Tavolo monolite che esalta nella purezza statuaria del marmo e della ceramica finemente lavorata, la sua immagine scenica. Realizzato a Vietri - una delle culle storiche della lavorazione della Ceramica Italiana - Dione Table ha forma rotonda e dimensioni scultoree. Base a forma di campana realizzata in ceramica artigianale di Vietri a coste, finitura smaltata bianca, che poggia su una piastra circolare in metallo con finitura oro opaco. Piano in prezioso marmo Calacatta o White Silk opaco con bordi a spizza, disco centrale e dettagli realizzati in ottone satinato opaco.

Monolith table that enhances the statuary purity of finely worked marble and ceramics, its scenic image. Made in Vietri - one of the historic cradles of Italian ceramic manufacturing - Dione Table has a round shape and sculptural dimensions. Bell-shaped base made of Vietri artisan ribbed ceramics, white enamel finish, resting on a circular metal plate with matt gold finish. Top in precious Calacatta marble or White silk matt with raised edges, central disc and details in brass satin matt.

Ø160

Ø180

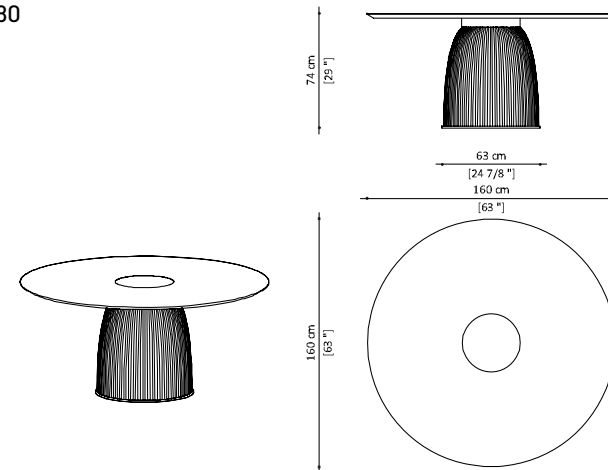

Ø160 WHITE SILK | TAV.DION.322

Top in White Silk marble matt - Mat brass details
3D Ceramic base - Mat gold details

Ø160 CALACATTA | TAV.DION.320

Top in Calacatta marble - Mat brass details
3D Ceramic base - Mat gold details

Ø180 WHITE SILK | TAV.DION.312

Top in White Silk marble matt - Mat brass details
3D Ceramic base - Mat gold details

Ø180 CALACATTA | TAV.DION.310

Top in Calacatta marble - Mat brass details
3D Ceramic base - Mat gold details





C



◀ **Ceramica artigianale realizzata e modellata a mano presso antichi laboratori a Vietri.**

Handmade artisan ceramic manually operated in antique Vietri laboratories.

Inspiration

C

DIONE LAZY SUSAN

DESIGN | PAOLO CASTELLI



3D Striped
Ceramic
from Vietri



Marble
Calacatta



Metal Finish
Matt Gold



Matt
Brass



Marble
White Silk
(top alternative)

Tavolo monolite che esalta nella purezza statuaria del marmo e della ceramica finemente lavorata, la sua immagine scenica. Realizzato a Vietri - una delle culle storiche della lavorazione della Ceramica Italiana - Dione Table ha forma rotonda e dimensioni scultoree. Base a forma di campana realizzata in ceramica artigianale di Vietri a coste, finitura smaltata bianca, che poggia su una piastra circolare in metallo con finitura oro opaco. Piano in prezioso marmo Calacatta o White Silk opaco con bordi a spizza, disco centrale e dettagli realizzati in ottone satinato opaco.

Monolith table that enhances the statuary purity of finely worked marble and ceramics, its scenic image. Made in Vietri - one of the historic cradles of Italian ceramic manufacturing - Dione Table has a round shape and sculptural dimensions. Bell-shaped base made of Vietri artisan ribbed ceramics, white enamel finish, resting on a circular metal plate with matt gold finish. Top in precious Calacatta marble or White silk matt with raised edges, central disc and details in brass satin matt.

Ø 160 - lazy susan Ø 80 cm

Ø 180 - lazy susan Ø 80 cm

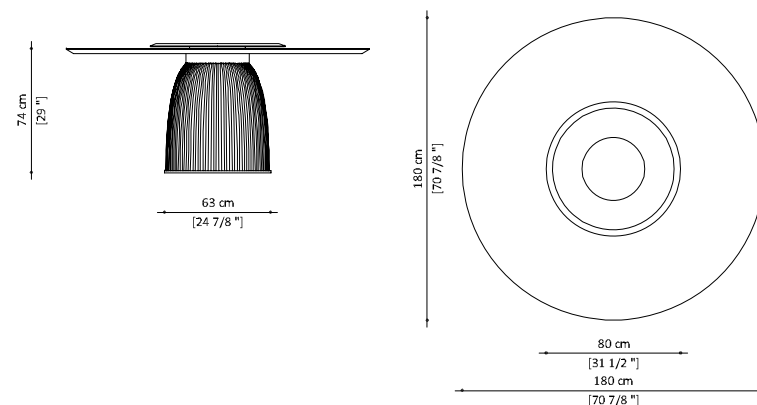

Ø 160 WHITE SILK | TAV.DION.323

Top in White Silk marble matt - Mat brass details
3D Ceramic base - Mat gold details

Ø 160 CALACATTA | TAV.DION.321

Top in Calacatta marble - Mat brass details
3D Ceramic base - Mat gold details

Ø 180 WHITE SILK | TAV.DION.313

Top in White Silk marble matt - Mat brass details
3D Ceramic base - Mat gold details

Ø 180 CALACATTA | TAV.DION.311

Top in Calacatta marble - Mat brass details
3D Ceramic base - Mat gold details

DIONE LAZY SUSAN 220

DESIGN | PAOLO CASTELLI

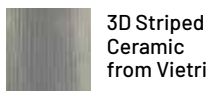

3D Striped
Ceramic
from Vietri



Marble
Calacatta



Metal Finish
Matt Gold



Marble
White Silk
(top alternative)

Tavolo monolite che esalta nella purezza statuaria del marmo e della ceramica finemente lavorata, la sua immagine scenica. Realizzato a Vietri - una delle culle storiche della lavorazione della Ceramica Italiana - Dione Table ha forma rotonda e dimensioni scultoree. Base a forma di campana realizzata in ceramica artigianale di Vietri a coste, finitura smaltata bianca, che poggia su una piastra circolare in metallo con finitura oro opaco. Piano in prezioso marmo Calacatta o White Silk opaco con bordi a spizza, disco centrale e dettagli realizzati in metallo finitura oro satinato opaco.

Monolith table that enhances the statuary purity of finely worked marble and ceramics, its scenic image. Made in Vietri - one of the historic cradles of Italian ceramic manufacturing - Dione Table has a round shape and sculptural dimensions. Bell-shaped base made of Vietri artisan ribbed ceramics, white enamel finish, resting on a circular metal plate with matt gold finish. Top in precious Calacatta marble or White silk matt with raised edges, central disc and details in metal matt gold finish.

Ø 220- lazy susan Ø 120 cm

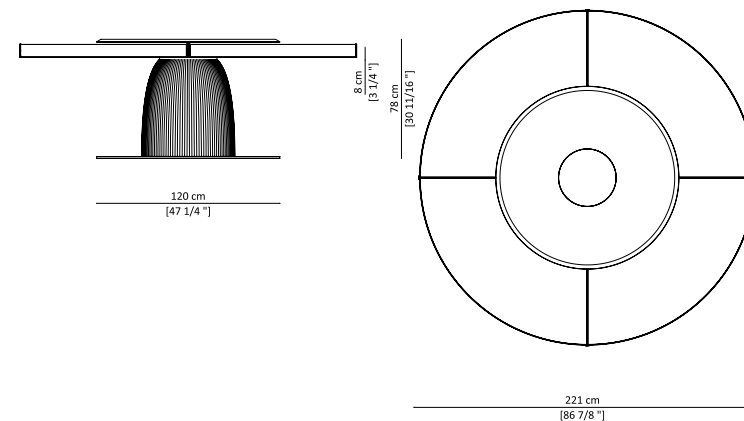

Ø 220 WHITE SILK | TAV.DION.332

Top in White Silk marble matt - Mat gold details
3D Ceramic base - Mat gold details

Ø 220 CALACATTA | TAV.DION.331

Top in Calacatta marble - Mat gold details
3D Ceramic base - Mat gold details



Inspiration



MARS TABLE

DESIGN | PAOLO CASTELLI

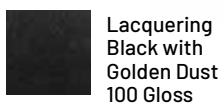

Lacquering
Black with
Golden Dust
100 Gloss



Metal Finish
Matt Gold



Lacquering
Black
100 gloss

Mars Table è un affascinante tavolo, decorato da una cascata di polvere d'oro che rende unici importanti ingressi e sofisticate sale da pranzo, caratterizzato anche da una base sferica dai rimandi galattici. Il tavolo ha un piano circolare in MDF di spessore 4 cm, con una preziosa laccatura lucida nera 100 gloss che incorpora polvere d'oro gettata a mano a più strati, creando un effetto tridimensionale che ne esalta la bellezza. La base è formata da una elegante campana in alluminio tornito in lastra con motivo rigato tridimensionale, finitura color oro opaco e che poggia su una base tonda sempre in mdf laccata nero lucido 100 gloss.

Mars Table is a fascinating table defined by its gold dust decorated top and elegant spherical base with a three-dimensionally striped pattern that bring a unique style to important entrances and sophisticated dining rooms.

The round, the 4 cm thick top is made from MDF with a precious 100 gloss lacquered finish that includes gold dust sprinkled by hand over multiple layers, creating a three-dimensional effect that enhances its beauty. The base is made of a turned aluminium bell with a three-dimensionally striped pattern matt gold finish and placed on a round mdf pedestal with a black 100 gloss lacquered finish.

Ø 160
Ø 180
Ø 200

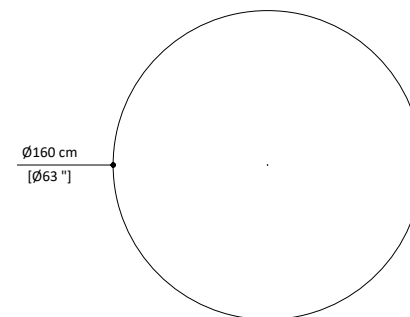
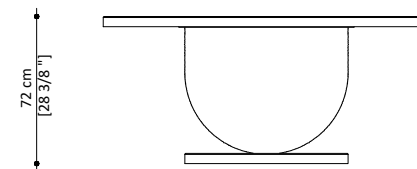

Ø 160 | TAV.MARS.330

Top laquered 100 gloss black with golden dust metal
Support in metal striped col. matt gold - Round base laquered 100 gloss black

Ø 180 | TAV.MARS.310

Top laquered 100 gloss black with golden dust metal
Support in metal striped col. matt gold - Round base laquered 100 gloss black

Ø 200 | TAV.MARS.320

Top laquered 100 gloss black with golden dust metal
Support in metal striped col. matt gold - Round base laquered 100 gloss black





C



◀ **Laccatura 100 gloss
impresiosita da polvere d'oro
gettata a mano a più strati.**

100 gloss lacquering enhanced
by golden powder spread by
hand.

Inspiration



TWELVE TABLE

DESIGN | PAOLO CASTELLI

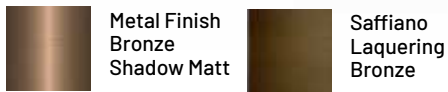

Alternative top options

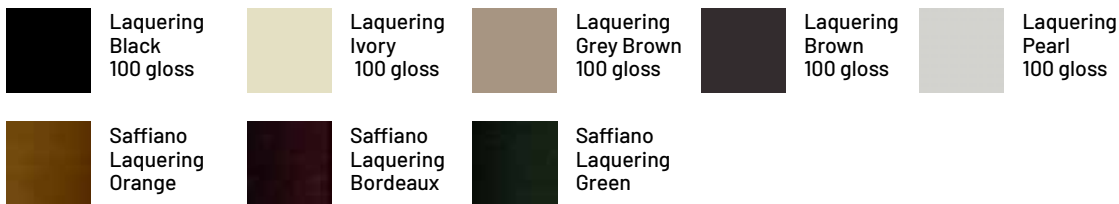

Tavolo con struttura di sostegno dalle gambe geometriche in metallo a sezione quadrata con finitura Bronze shadow opaco. Il piano, dagli angoli arrotondati, presenta dimensioni importanti ed è disponibile in MDF (spessore 2 cm) con laccatura lucida 100 gloss in versione monocromatica oppure nella versione in MDF laccato lucido 100 gloss impreziosito da una sfumatura radiale sulle tonalità dell'oro arricchito da un pattern in saffiano, colore bronzo. Bordo a spazza che consente al piano di incastonarsi nella struttura.

Table with supporting structure with geometric legs in metal section with opaque Bronze shadow finish. The top, with rounded corners, has important dimensions and is available in MDF (2 cm thick) with glossy gloss lacquer 100 gloss in monochromatic version or in the version in 100 gloss lacquered MDF embellished with a radial gradient on the shades of gold enriched by a pattern in saffiano, bronze color. Spatical edge that allows the plane to be embedded in the structure.

L 280

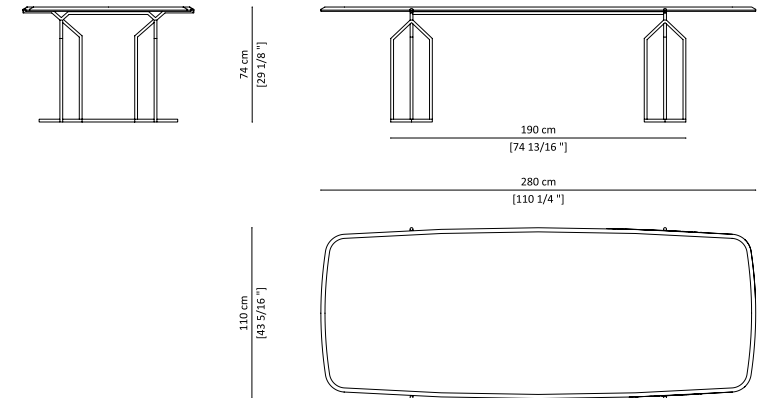

LACQUERED | TAV.TWEL.301

Top Lacquered 100 Gloss in colours: Black Ral 9005, Ivory Ral1013, Brown grey Ncs 5010 Y50r, Brown Ral 8019
Base in metal bronze shadow matt finish

SAFFIANO | TAV.TWEL.311

Lacquered Saffiano finish 100 Gloss in colours: Bronze, Orange, Bordeaux, Green
Base in metal bronze shadow matt finish

L 340

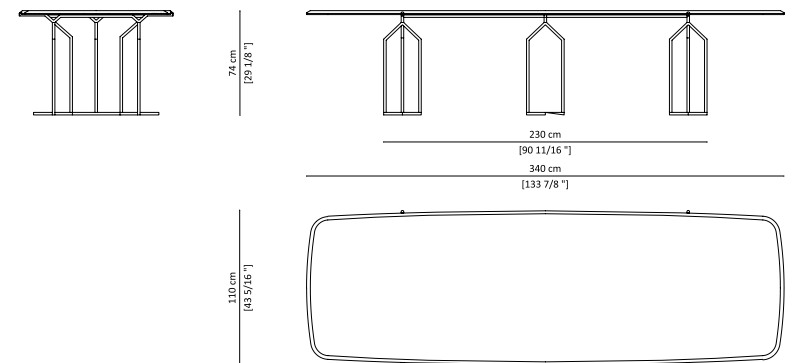

LACQUERED | TAV.TWEL.302

Top Lacquered 100 Gloss in colours: Black Ral 9005, Ivory Ral1013, Brown grey Ncs 5010 Y50r, Brown Ral 8019
Base in metal bronze shadow matt finish

SAFFIANO | TAV.TWEL.312

Lacquered Saffiano finish 100 Gloss in colours: Bronze, Orange, Bordeaux, Green
Base in metal bronze shadow matt finish



◀ **Pattern Saffiano: decorazione artigianale che riprende le più esclusive lavorazioni tipiche dalle concerie del distretto Toscano.**

Saffiano pattern: handcrafted tanning typical of Tuscan district.

Inspiration

C

FOR HALL TABLE OVAL

DESIGN | PAOLO CASTELLI



Metal Finish
Matt Gold



Marble
Calacatta

Alternative top options



Marble
White
Silk



Marble
Black
Sahara



Marble
Silver
Brown



Marble
Bronze
Amani



Glass
Grey
Brown



Glass
Amaranth

For Hall Table Oval è un tavolo realizzato con un piano ellittico con bordi ad ala di gabbiano in pregiato marmo. La struttura si compone di due basi con 8 gambe ciascuna, realizzate in metallo con pregiata finitura oro opaco, disposte con diverse inclinazioni. Spessore piano 2cm.

Il tavolo è disponibile anche in versione con top in vetro lucido retrolaccato colore RAL 8019.(spessore 1,2 cm).

For Hall Table Oval is made with an elliptical top with gull-wing edges in precious marble. The structure consists of two bases with 8 legs each, made of metal with high-quality matte gold finish, arranged with different inclinations. Thickness 2cm.

The table is also available in a version with RAL 8019 back-lacquered glossy glass top (1,2 cm thick).

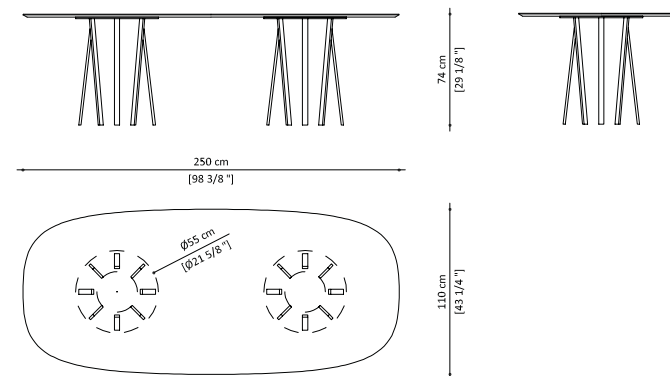

GLASS TRANSPARENT | TAV.FORH.310G

Metal base mat gold finished - Glass top made in transparent glass - col. Avana

BACKLACQUERED GLASS TOP | TAV.FORH.300G

Metal base mat gold finished
Backlacquered glass top gloss finish. Colours: col. Grey Brown Ral 8019, Amaranth Ral 3007

WHITE SILK | TAV.FORH.303

Metal base mat gold finished - White Silk marble matt

SILVER BROWN WAVE | TAV.FORH.300

Metal base mat gold finished - Silver brown wave marble top

BRONZE AMANI | TAV.FORH.300

Metal base mat gold finished - Bronze Amani marble top

CALACATTA | TAV.FORH.304

Metal base mat gold finished - Calacatta marble top



C



Inspiration

C

FOR HALL SQUIRCLE

DESIGN | PAOLO CASTELLI



Metal Finish
Matt Gold



Marble
Black Sahara

Alternative top options



Marble
White Silk



Marble
Silver Brown



Marble
Bronze Amani



Marble
Calacatta

È realizzato con un piano quadrato con angoli arrotondati e bordi ad ala di gabbiano in pregiato marmo, spessore 2cm. La base si compone di 8 gambe in metallo con finitura oro opaca, disposte con diverse inclinazioni, fissate al piano tramite una piastra in metallo. Disponibile anche la versione con piano in vetro retrolaccato col. marrone Ral 8019, spessore piano 1,2 cm.

It features a square top with rounded corners and gullwing edges made in marble - 2 cm thick. The base comprises 8 metal legs with a matt gold finish, set at different angles and anchored to the table top with a metal plate. Also available the model with glass top - backpainted brown Ral 8019 (1,2 cm thick).

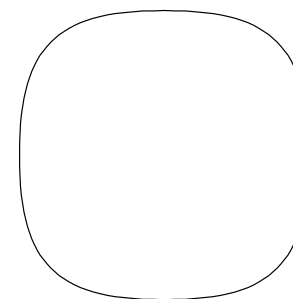
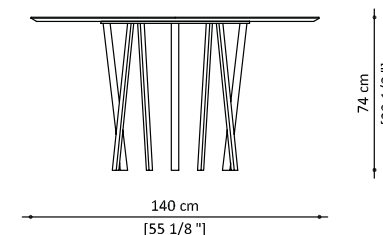

WHITE SILK | TAV.FORH.313

Metal base mat gold finished - White Silk marble matt

MARBLE | TAV.FORH.311

Metal base mat gold finished
Available marbles: Bronze Amani - Black Sahara - Silver Brown Wave

CALACATTA | TAV.FORH.314

Metal base mat gold finished - Calacatta marble top

FOR HALL CIRCLE

DESIGN | PAOLO CASTELLI



Metal Finish
Matt Gold



Glass
Amaranth

Alternative top options



Glass
Grey
Brown



Transparent
glass col. Avana

È realizzato con un piano circolare in vetro, disponibile in finitura retrolaccata col grigio marrone Ral 8019, o Amarantho Ral 3007, oppure in vetro trasparente color Avana. La base si compone di 8 gambe in metallo con preziosa finitura oro opaca, disposte con diverse inclinazioni. Spessore piano 1,2 cm.

Is made by a circular top made in glass backlacquered col. grey brown Ral 8019, or Amaranth Ral 3007, or in transparent glass col. Avana. The base comprises 8 metal legs with a matt gold finish, set at different angles and anchored to the table top with a metal plate. Top is 1,2 cm thick.

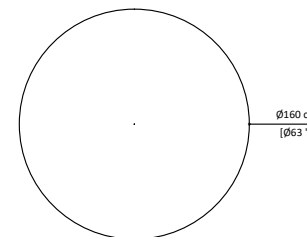
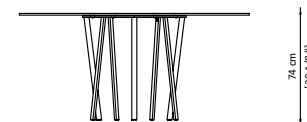

Ø 160 TRANSPARENT GLASS | TAV.FORH.321

Metal base matt gold finished - Glass top made in transparent glass - col. Avana

Ø 160 BACKLACQUERED GLASS | TAV.FORH.320

Metal base matt gold finished
Backlacquered glass top gloss finish. Colours: col. Grey Brown Ral 8019, Amaranth Ral 3007

Inspiration

BLACK & GOLD

DESIGN | LUCA SCACCHETTI

C



Metal Finish
Matt Flamed
Brass



Laquering
Black
100 gloss

Alternative top options



Laquering
Pearl
100 gloss

Una collezione di tavoli, dalle forti linee geometriche e caratterizzati da un accostamento di materiali inedito e di grande eleganza: uno più naturale, architettonico in metallo e un altro più finito, lucido e decorativo, il laccato nero. Un ripasso o rivisitazione dell'astrattismo italiano del primo dopoguerra.

Il grande tavolo rettangolare è composto da un piano in mdf verniciato lucido nero 100 gloss, con bordi dei lati corti leggermente rastremati e quelli dei lati lunghi che sembrano fondersi nelle due basi massicce ed eleganti al tempo stesso, realizzate in metallo pieno con preziosa lavorazione in ottone fiammato opaco. Spessore piano 3,2 cm. Disponibile la versione Pearl & Gold con piano laccato lucido col. bianco perla NCS S 1500N.

A collection of tables with strong geometric lines defined by an unusual and very elegant combination of materials: one more natural, marked, architectural, in metal, and the other more finished, decorative and luxurious, lacquered black.

A reinterpretation of post-war Italian abstractionism. The large rectangular table has a mdf top with a black 100 gloss lacquered finish with gullwing edges on the shorter sides of the table, and the solid and elegant metal structure parts, with an opaque, iridescent brass finish, inserted along the long sides.

Top 3,2 cm thick. Also available the Pearl & Gold model, with white top lacquered 100 gloss NCS S 1500N

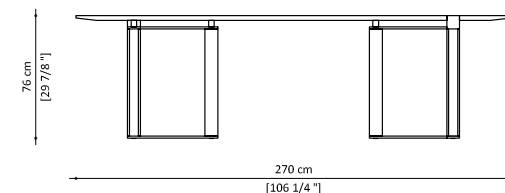

270 cm
[106 1/4 "]

76 cm
[29 7/8 "]

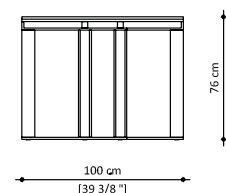

76 cm
[29 7/8 "]

100 cm
[39 3/8 "]



BLACK & GOLD TABLE | TAV.BLAC.320

Mat flamed brass structure - Lacquered top 100 gloss
Available colours: Black Ral 9005, White Pearl NCS S 1500N



◀ **Galvanica: prezioso processo di trattamento dell'ottone in grado di conferire allo stesso un'inaspettata tridimensionalità.**

Galvanic process: galvanic bath which gives to brass precious three-dimensional effect.

FLORA TABLE

DESIGN | PAOLO CASTELLI



Metal Finish
Matt Gold



Marble
White Silk

Alternative top options



Laquering
Black
100 gloss



Laquering
Ivory
100 gloss



Laquering
Grey Brown
100 gloss



Laquering
Brown
100 gloss



Laquering
Pearl
100 gloss



Marble
Calacatta

Flora è un prezioso tavolo dai rimandi naturalistici, con una base intrecciata e realizzata interamente a mano, ideale per arredare eleganti ambienti privati e pubblici. Il tavolo ha una struttura formata da tondini intrecciati tra loro in metallo, finitura oro opaco. La preziosità di questo tavolo è esaltata dal peculiare piano in pregiati marmi. Spessore piano 2cm.

Flora is a precious table with naturalistic references, with a woven base and made entirely by hand, ideal for furnishing elegant private and public environments. The table has a structure formed by intertwined steel rods, finished in opaque gold. The preciousness of this table is enhanced by the peculiar top in precious marble. Top is 2cm thick.

ROUND

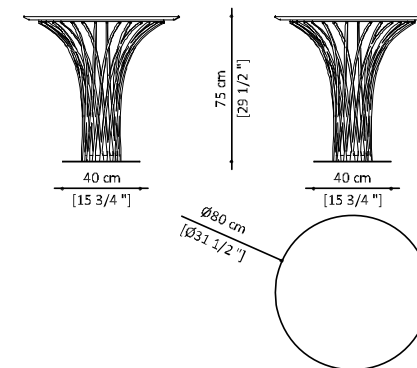

ROUND LACQUERED | TAV.FLOR.300

Top Lacquered 100 Gloss in colours: Black Ral 9005, Ivory Ral1013, Brown grey Ncs 5010 Y50r, Brown Ral 8019
Base in metal mat gold finished

ROUND WHITE SILK | TAV.FLOR.313

Metal base mat gold finished - White Silk marble matt

ROUND CALACATTA | TAV.FLOR.314

Metal base mat gold finished - Calacatta marble top

OVAL

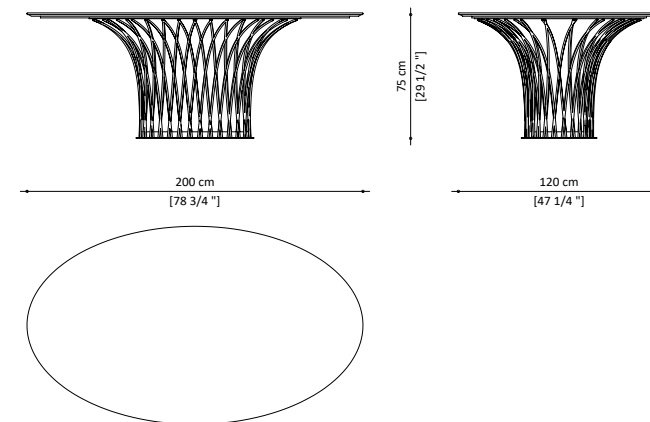

OVAL LACQUERED | TAV.FLOR.320

Top Lacquered 100 Gloss in colours: Black Ral 9005, Ivory Ral1013, Brown grey Ncs 5010 Y50r, Brown Ral 8019, Pearl NCS S 1500 N
Base in metal mat gold finished

OVAL WHITE SILK | TAV.FLOR.323

Metal base mat gold finished - White Silk marble matt

OVAL CALACATTA | TAV.FLOR.324

Metal base mat gold finished - Calacatta marble top



C



Inspiration



NETTUNO DESK

DESIGN | VITTORIO PARADISO



Metal Finish
Black Nickel
Matt striped



Bovine Leather
Col. 674 Siena

Declinazione da ufficio del tavolo Nettuno. Top rivestito in pelle pieno fiore con bordo perimetrale in metallo finitura nichel nero satinato opaco con dettagli oro satinato opaco, base in metallo plissettato finitura nichel nero lucido. Cassettiera indipendente, completamente rivestita in pelle pieno fiore, apertura push pull e serratura di sicurezza.

Office adaptation of the Nettuno table. Top covered in full grain leather with metal perimeter edges in matt black satin nickel finish with matt satin golden details, base in pleated metal with a shiny black nickel finish. Independent drawer, completely covered in full grain leather, push-to-open drawer slides and security door lock.

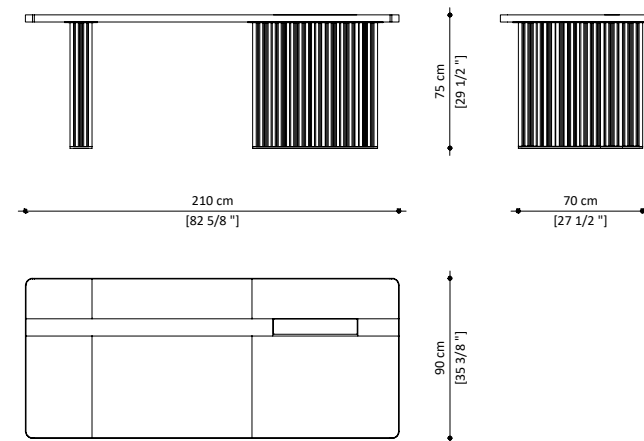

L210 | TAV.NETT.310

Top in wood covered in full grain leather - matt satin finish gold details
Base in pleated metal with a shiny black nickel finish.





Inspiration



MY BEAUTY

DESIGN | PAOLO CASTELLI



Laquering Pearl 100 gloss

Alternative colour options

Laquering Black 100 gloss

Laquering Ivory 100 gloss

Laquering Grey Brown 100 gloss

Laquering Brown 100 gloss

My Beauty è un grazioso mobile toeletta dedicato all'universo femminile, con una struttura a ponte, ribaltina centrale apribile con specchio illuminato a led, vano centrale rivestito internamente in microfibra, e due cassetti laterali imbottiti e rivestiti in microfibra. E' realizzata interamente in mdf laccato lucido 100 gloss. Su richiesta è disponibile la versione con jewellery box centrale.

My Beauty is a makeup desk dedicated to women, with a bridge structure and central flap concealing a led lit mirror, with central compartment and two side drawers upholstered and lined in microfibra. It is entirely made from mdf with a 100 gloss lacquered finish. Optional jewellery box is available on request.

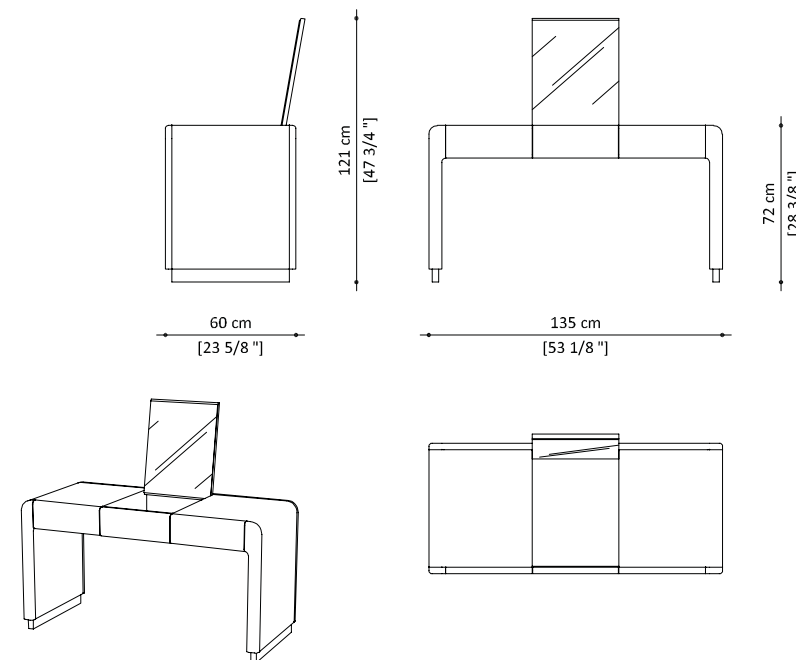

MY BEAUTY | TAV.MYBE.200

Lacquered 100 Gloss in colours: Black Ral 9005, Ivory Ral1013, Brown grey Ncs 5010 Y5Or, Brown Ral 8019, Pearl NCS S 1500 N
Microfiber internal covering

MY BEAUTY WITH JEWELRY BOX | TAV.MYBE.210

Lacquered 100 Gloss in colours: Black Ral 9005, Ivory Ral1013, Brown grey Ncs 5010 Y5Or, Brown Ral 8019, Pearl NCS S 1500 N
Microfiber internal covering
Inner jewellery box with leather details

Inspiration

C

MY TOY DESK

DESIGN | PAOLO CASTELLI



Metal Finish
Matt Gold



Wood
Walnut



Bovine
Nabuk col. 01
Chocolate

My Toy è realizzato con un piano in legno, impiallacciato in noce americano, con cassetto ed un pannello centrale rivestito in elegante pelle, che poggia su una struttura a x in metallo con una preziosa lavorazione oro opaco. Il piano è dotato di vano apribile per inserimento prese elettriche. La scrivania è disponibile anche nella versione con piano completamente rivestito in nabuk.

My Toy features an x-shaped metal support structure, with a matt gold finish, and hickory wood top with a drawer and a central panel covered in elegant leather. The top is equipped with an opening compartment for inserting electrical sockets. The desk is also available in the version with a completely covered in nubuck top.

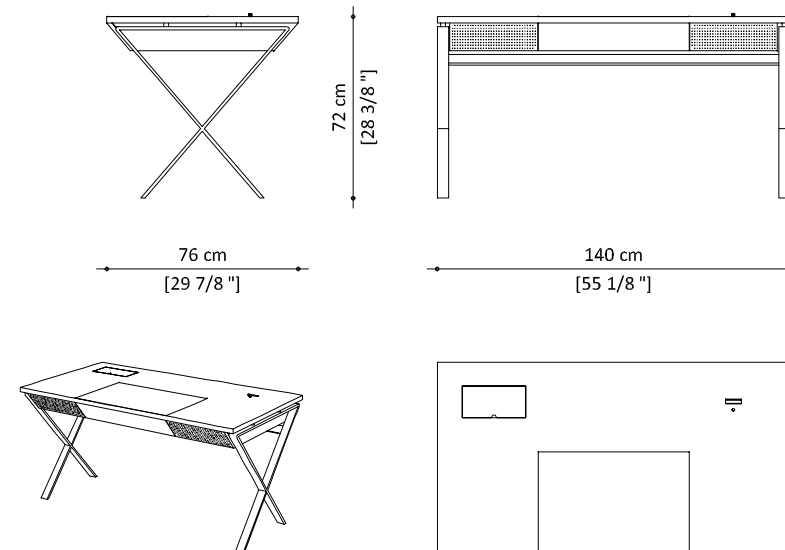

WOOD | TAV.MYTO.300

Wooden top walnut
Metal base - finish mat gold

NABUK | TAV.MYTO.310

Wooden top covered in nabuk
Metal base - galvanic finish mat gold

Inspiration



BDS DESK

DESIGN | BORROMEODESILVA



Metal Finish
Matt Gold



Wood
Black Ashwood

Bds Desk è un'elegante scrivania dalle geometrie decise e razionali che bene si sposa con il concetto dell'home office e di un ufficio direzionale qualificato. La scrivania ha una struttura in metallo, dal pregevole disegno, con finitura oro opaco ed un piano attrezzato con cassetto e vani laterali a giorno realizzati in essenza di frassino black. Il cassetto ha apertura push-pull e serratura invisibile. La scrivania è inoltre dotata sul piano di un vano apribile per l'inserimento di apposite prese di corrente. In una delle gambe della struttura può scorrere il filo elettrico delle prese.

Bds Desk is an elegant desk, boasting bold and rational lines, that will complement home offices as well as elegant corporate spaces.

The desk features a metal structure, boasting a fine design and a matt gold finish, and a black ash top with a drawer and open compartments on the sides. The drawer has a push-pull opening mechanism and invisible lock. The desk also has a side compartment on the top to allow to plug devices into wall sockets. Electric cables can run through one of the legs.

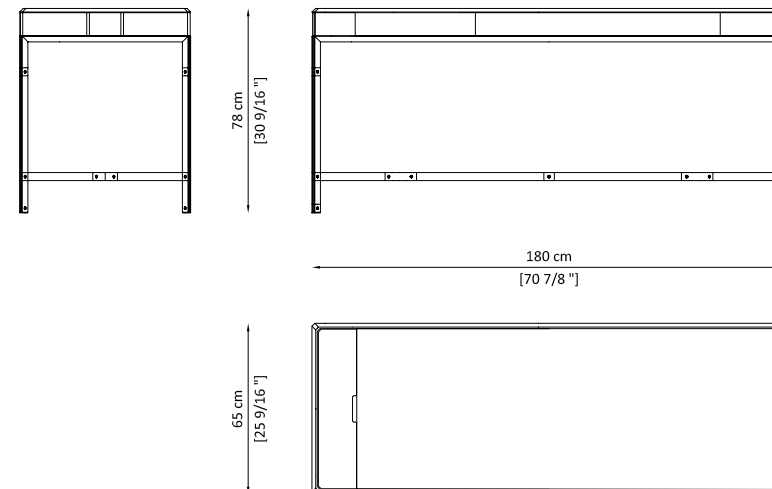

BDS DESK | TAV.BDST.310

Wooden top black ash
Base in metal matt gold



C



◀ Predisposizione salita cavi tramite una delle gambe della scrivania.

Electrical cables can pass through the metal structure.

TWELVE CONSOLE

DESIGN | PAOLO CASTELLI



Metal Finish
Matt Gold



Marble
Calacatta

Alternative top options



Marble
White Silk



Marble
Black Sahara

Console di leggera eleganza e di forte presenza, trova il suo elemento caratterizzante nella struttura di sostegno con gambe geometriche in metallo con finitura oro satinato. Il piano dallo spessore di 2 cm è disponibile in marmo. Espressione di un'estetica raffinata, Twelve console non teme l'accostamento con altri stili.

A console of light elegance and powerful presence, its characteristic element lies in the support structure with geometric metal legs and satin gold finish. The 2 cm thick top is available in Calacatta marble. Expression of a refined aesthetic, Twelve console matches well with other styles.

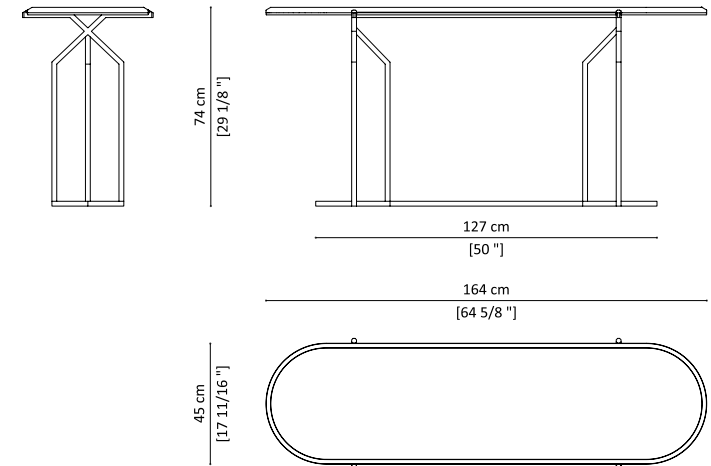

WHITE SILK | TAV.TWEL203

Metal base matt gold finished - White Silk marble matt

BLACK SAHARA | TAV.TWEL201

Metal base matt gold finished - Black Sahara marble top

CALACATTA | TAV.TWEL.204

Metal base matt gold finished - Calacatta marble top



CE



FOR HALL CONSOLE

DESIGN | PAOLO CASTELLI



Metal Finish
Matt Gold

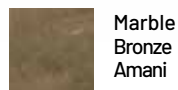

Marble
Bronze
Amani

Alternative top options



Marble
White
Silk

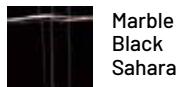

Marble
Black
Sahara



Marble
Silver
Brown



Marble
Calacatta

È realizzato con un piano ovale e angoli ad ala di gabbiano in pregiato marmo. La base si compone di 7 gambe in metallo con finitura oro opaco, disposte con diverse inclinazioni e saldate a un disco di fissaggio in metallo che viene fissato al piano tramite viti metalliche. Spessore piano 2cm

It comprises an oval-shaped top with rounded corners in precious marble. The base features 7 metal legs with a matt gold finish, set at different angles and welded onto a metal disk that is fixed to the table top with metal screws. Top thick 2 cm.

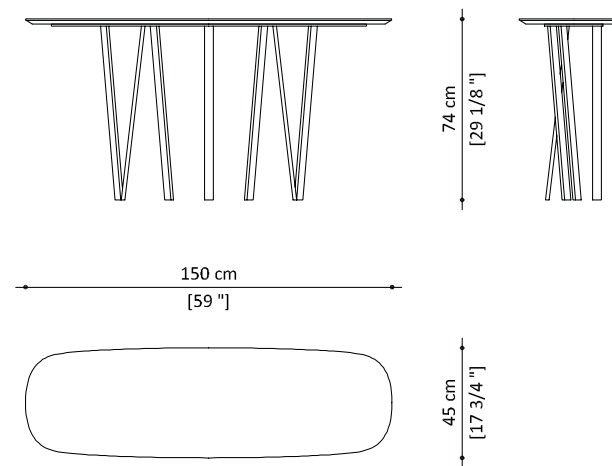

WHITE SILK | TAV.FORH.202

Mat gold finish base
White Silk marble matt

MARBLE | TAV.FORH.201

Mat gold finish base
Available marbles: Bronze Amani, Silver Brown Wave, Black Sahara

CALACATTA | TAV.FORH.204

Mat gold finish base
Calacatta marble top



C



REVERSE CONSOLE

DESIGN | PAOLO CASTELLI



Alternative top options

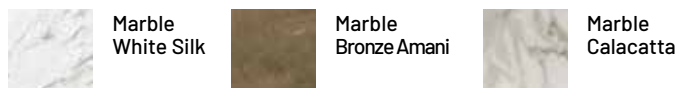

Console dal disegno apparentemente semplice in cui la base incrociata alterna gambe in metallo trattato con finitura oro opaco e gambe in rovere cotto.

La proposta di abbinamenti materici all'insegna di un'inedita eleganza prosegue nella scelta del piano in marmo dallo spessore di 2 cm.

Linee e materiali ridefiniscono l'estetica degli anni "ruggenti" che, contaminata dalla sensibilità contemporanea della collezione Inspiration, contribuisce a dare prestigio e luminosità all'ambiente in cui è inserito.

Of apparently simple design, the base of the console alternates legs in finish mat gold treated metal and in dark stained oak.

The proposal of materic matching in the name of an unprecedented elegance proceeds in the choice of the top in 2 cm thick in marble. Lines and materials redefine the aesthetics of the "roaring" years which, intermingled with the contemporary sensibility of the Inspiration collection, contributes to lending prestige and luminosity to its setting.

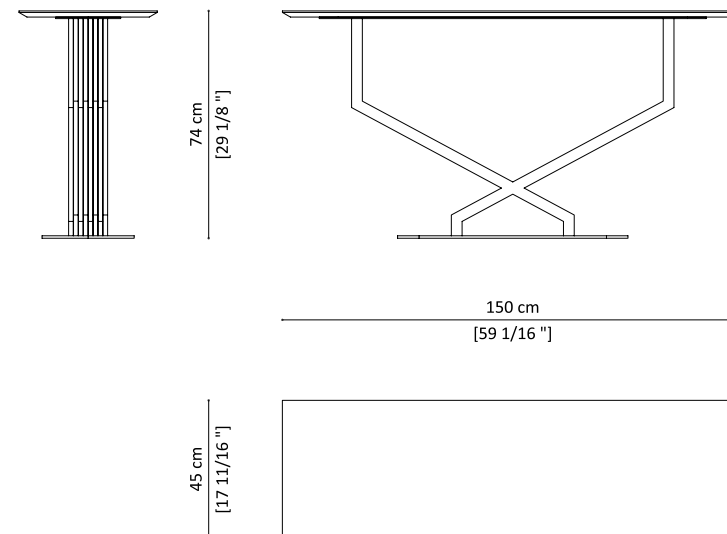

WHITE SILK | TAV.REVE.203

Marble top, mat gold finished metal base with dark stained oak inserts
White Silk marble matt or polished

BLACK SAHARA | TAV.REVE.201

Marble top, mat gold finished metal base with dark stained oak inserts
Black Sahara marble top

BRONZE AMANI | TAV.REVE.202

Marble top, mat gold finished metal base with dark stained oak inserts
Bronze Amani marble top

CALACATTA | TAV.REVE.204

Marble top, mat gold finished metal base with dark stained oak inserts
Calacatta marble top

Inspiration



CULTUM CONSOLE

DESIGN | PAOLO CASTELLI



Metal Finish
Bronze
Shadow Mat



Transparent
glass col. Avana



Pece
Stone



Mirrored
undulated glass
col. Avana

Options for back disc

Cultum console è un linguaggio polimaterico, non il design di un complemento ma lo sviluppo di un'idea che si fa gesto.

Struttura in metallo finitura bronze shadow opaco, con ripiani e disco anteriore in vetro temperato col. Avana (sp. 6 mm). Il disco posteriore -disponibile in pietra pece oppure in vetrofuso ondulato retrolaccato col. Avana- definisce i confini tridimensionali di questo oggetto multiforme.

Cultum console is a multi-material language, achieved not by designing a piece of furniture but by developing an idea into a gesture.

Metal structure with a matt bronze shadow finish, with tempered glass shelves and front disc (6 mm thick). Back disc -available in Pece stone or in mirrored undulated glass col. Avana- defines the three-dimensional boundaries of this multiform object.

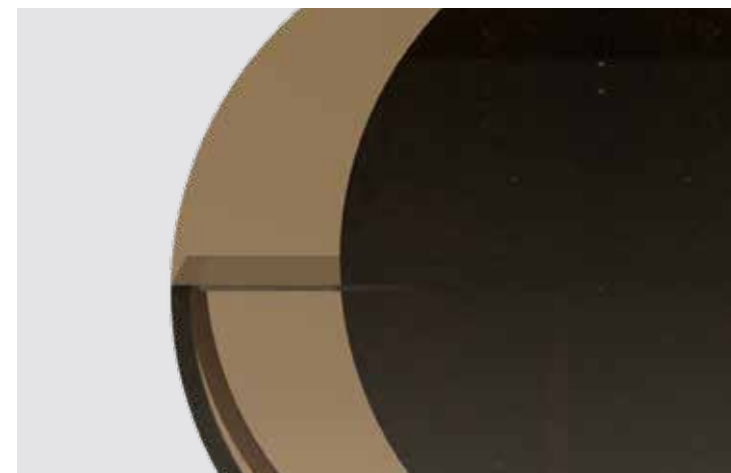
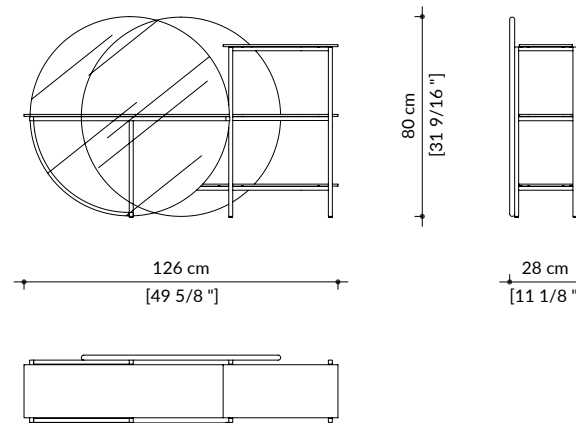

MIRRORED UNDULATED GLASS | TAV.CULT.200

Metal frame mat gold finished - Shelves and front disc made in transparent glass col. Avana
Back disc made in mirrored undulated backlaquered glass col. Avana

PECE STONE | TAV.CULT.210

Metal frame mat gold finished - Shelves and front disc made in transparent glass col. Avana
Back disc made in Pece stone

Inspiration



BLACK & GOLD CONSOLE

DESIGN | LUCA SCACCHETTI



Metal Finish
Matt Flamed
Brass



Laquering
Black
100 gloss

Alternative top options



Laquering
Ivory
100 Gloss

La console Black & Gold Console, esalta l'accostamento di materiali inedito e di grande eleganza: uno più naturale, macchiato, architettonico in metallo e un altro più finito, lucido, decorativo e lussuoso, il laccato nero, spessore 3.2 cm. Si tratta di una console con un piano in mdf verniciato lucido nero 100 gloss, con i lati corti dal bordo inferiore leggermente rastremato, e una doppia base realizzata in metallo pieno con elegante lavorazione in ottone fiammato opaco. Disponibile la versione Pearl & Gold con piano laccato lucido col. bianco perla NCS S 1500N.

The Black & Gold Console is defined by an unusual and very elegant combination of materials: one more natural, marked, architectural, in metal, and the other more finished, shiny, decorative and luxurious, lacquered black, 3,2 cm thick. It features a mdf top with a black 100 gloss lacquered finish; the bottom edge of the short ends are slightly flared and the double base is made of solid metal with a burnished matt brass finish. Top 3,2 cm thick. Also available the Pearl & Gold model, with white top lacquered 100 gloss NCS S 1500N.

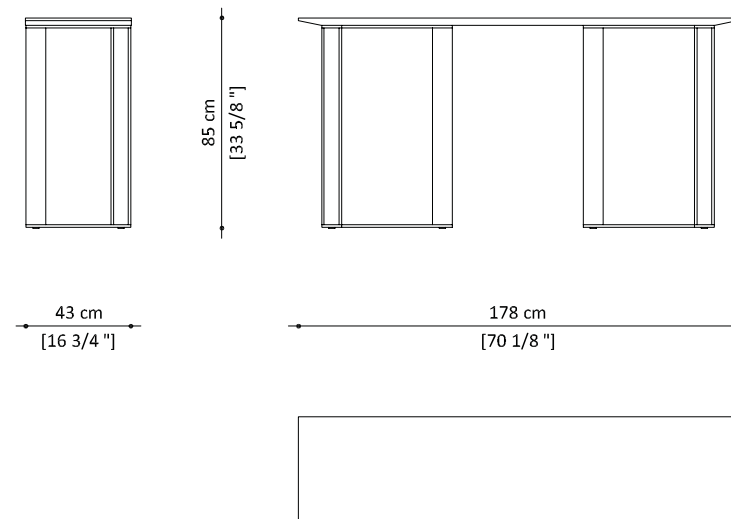

BLACK & GOLD CONSOLE | TAV.BLAC.200

Mat flamed brass structure - Lacquered top 100 gloss
Available colours: Black Ral 9005, White Pearl NCS S 1500N



◀ **Galvanica:** prezioso processo di trattamento dell'ottone in grado di conferire allo stesso un'inaspettata tridimensionalità.

Galvanic process: galvanic bath which gives to brass precious three-dimensional effect.

Inspiration

C

SEAN CONSOLE

DESIGN | PAOLO CASTELLI



Metal Finish
Matt Gold



Metal Finish
Polished
Black Nickel



Bronze
Mirrored Glass Matt

Console caratterizzata da una sofisticata semplicità delle linee, declinata in una scelta di materiali di grande pregio. Basamento in trafilati finitura oro satinato opaco, struttura in tubolare ellissoidale nichel nero lucido e top di forma ovale in specchio color bronzo satinato.

Console featuring a sophisticated simplicity of lines, offered with a choice of high quality materials. Base with a drawn matt gold finish, structure in ellipsoidal tubular shiny black nickel polished and oval top in bronze mirrored glass matt.

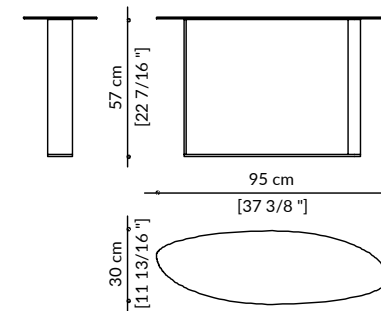

BACKLACQUERED GLASS | TAV.SEAN.200

Matt satin gold finish base - Polished black nickel structure
Bronze mirrored glass matt top



SOFT RATIO COFFEE TABLE

DESIGN | PAOLO CASTELLI



2 SHELVES

1 SHELF

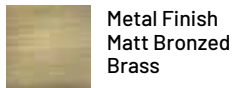

Metal Finish
Matt Bronzed
Brass



Metal Black
Matt varnished



Transparent
glass col. Avana
(top)



Pece
Stone

Alternative lower top option



Bovine Leather
Col. 602 Dark
Brown

Elegante tavolino che completa la proposta living e ben si abbina alla linea di contenitori e divani Soft Ratio. La base in metallo finitura nero opaco con doppi piedini in metallo finitura bronzo ottone opaco, evidenzia la leggerezza complessiva del progetto, sostenendo il ripiano superiore in vetro trasparente color Avana e quello inferiore in pietra Pece o in alternativa rivestito in pelle col. 602 testa di moro. Disponibile anche la versione a 1 ripiano in vetro col. Avana.

Elegant coffee table that completes the living proposal and well coordinates with the Soft Ratio line of containers and sofas. The metal base matt black finish with double metal feet matt bronzed brass finish, highlights the overall lightness of the project, supporting the top Havana coloured transparent glass, and the lower shelf in Pece stone or alternatively covered in leather col. 602 dark brown. Also available with one shelf in glass col. Avana.

1 SHELF

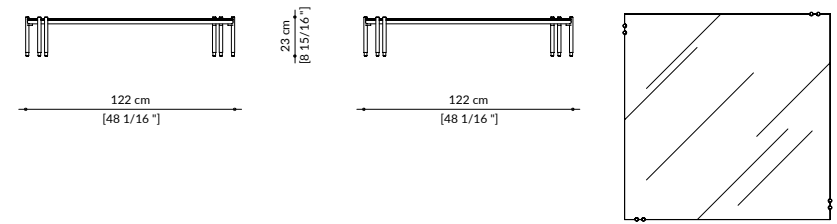

1 SHELF GLASS | TAV.SOFT.100

Metal base matt black finish with double metal feet matt bronzed brass finish
Top made in transparent glass col. Avana

2 SHELVES

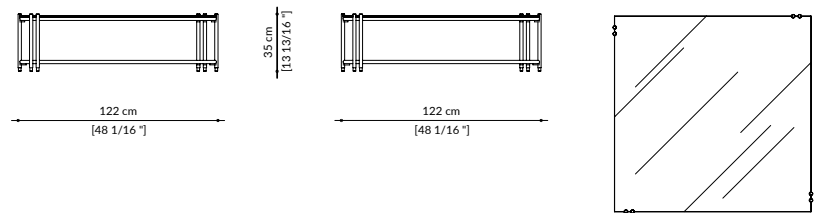

2 SHELVES LEATHER | TAV.SOFT.110

Metal base matt black finish with double metal feet matt bronzed brass finish
Top made in transparent glass col. Avana
Shelf covered in leather col. 602 dark brown

2 SHELVES STONE | TAV.SOFT.111

Metal base matt black finish with double metal feet matt bronzed brass finish
Top made in transparent glass col. Avana
Shelf in Pece stone



FOR HALL COFFEE TABLE

DESIGN | PAOLO CASTELLI



A

B

C



Metal Finish
Matt Gold

Available marbles



Marble
White Silk



Marble
Black Sahara



Marble
Silver Brown



Marble
Bronze Amani



Marble
Calacatta

I For Hall Coffee Tables sono una serie originale e preziosa di tavolini bassi, congeniali ad arredare spazi living, anche in composizioni con più elementi combinati tra loro. Sono composti da un piano realizzato in prezioso marmo e una base con gambe in metallo con finitura oro opaco.

The For Hall Coffee Tables are a range of original and elegant low tables, ideal to furnish living spaces also in combination with other elements. The top is made in marble and the base has legs made in metal with a matt gold finish.

A

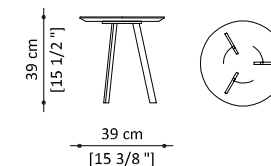

MARBLE | TAV.FORH.110

Marble top - metal base mat gold finished

Available marbles: Bronze Amani - Sahara Noir - Silver Brown Wave - White Silk

CALACATTA | TAV.FORH.114

Marble top Calacatta - metal base mat gold finished

B

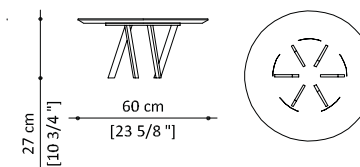

MARBLE | TAV.FORH.120

Marble top - metal base mat gold finished

Available marbles: Bronze Amani - Sahara Noir - Silver Brown Wave - White Silk

CALACATTA | TAV.FORH.124

Marble top Calacatta - metal base mat gold finished

C

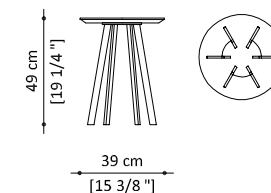

MARBLE | TAV.FORH.130

Marble top - metal base mat gold finished

Available marbles: Bronze Amani - Sahara Noir - Silver Brown Wave - White Silk

CALACATTA | TAV.FORH.134

Marble top Calacatta - metal base mat gold finished



CE



FOR HALL COFFEE TABLE

DESIGN | PAOLO CASTELLI



D



E



Metal Finish
Matt Gold

Available marbles



Marble
White Silk



Marble
Black Sahara



Marble
Silver Brown



Marble
Bronze Amani



Marble
Calacatta

Available glass for model E



Glass
Grey
Brown



Glass
Amaranth



Transparent
glass col. Avana

Sono composti da un piano realizzato in prezioso marmo e una base con gambe in metallo con finitura oro opaco. Il modello E è proposto anche con piano in vetro.

The top is made in marble and the base has legs made in metal with a matt gold finish. Model E is available also with glass top.

D

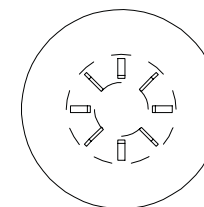
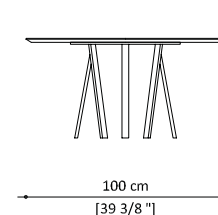

WHITE SILK | TAV.FORH.143

Marble top White Silk matt or polished- metal base mat gold finished

MARBLE | TAV.FORH.140

Marble top - metal base mat gold finished
Available marbles: Bronze Amani - Sahara Noir - Silver Brown Wave

CALACATTA | TAV.FORH.144

Marble top Calacatta - metal base mat gold finished

E

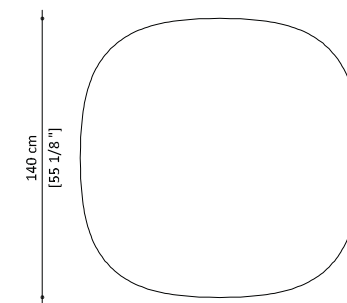
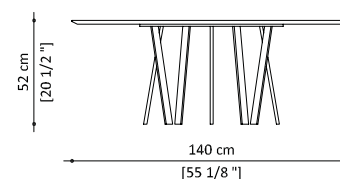

LACQUERED GLASS | TAV.FORH.150G

Backlacquered glass top 100 gloss - metal base mat gold finished
Available colors: Brown 100gloss RAL8019 - Amaranth RAL 3007

AVANA GLASS | TAV.FORH.151

Transparent glass top col. Avana - metal base mat gold finished

MARBLE WHITE SILK | TAV.FORH.153

Marble top White Silk matt or polished- metal base mat gold finished



DIONE COFFEE TABLE

DESIGN | PAOLO CASTELLI



A

C

B

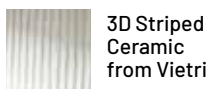

3D Striped
Ceramic
from Vietri



Matt
Brass



Marble
Calacatta

Alternative top option



Marble
White Silk

A - E' composto da base in ceramica di forma slanciata e piano in metallo oro opaco spazzolato, di spessore 3 mm. Basamento in metallo verniciato oro opaco.

B - Ha una base compatta in ceramica sormontata da un grande piano in marmo Calacatta con bordo spizzato di spessore 20 mm, al centro del quale è inserito un disco metallico in ottone satinato opaco. Basamento in metallo verniciato oro opaco. Disponibile anche con top in marmo bianco White silk opaco.

C - E' composto da base in ceramica e piano in marmo Calacatta con bordo spizzato di spessore 20 mm, che accoglie un inserto ad anello in metallo finitura oro opaco spazzolato. Basamento in metallo finitura oro opaco. Disponibile anche con top in marmo White Silk opaco.

A - Is composed of a ceramic base in slim shape and a metal top in mat gold finish, 3mm thick. The lower base is in metal mat gold finished.

B - Has a solid base on which a wide slab of Calacatta marble with 45° edges 20 mm thick stands. In the centre lies a metallic plate in mat gold finish. The lower base is in metal mat gold finish. Available also with top in marble White silk matt.

C - Is composed of a ceramic base and a top in Calacatta marble with 45° edges 20mm thick. It includes a ring shape metallic insert in finish mat gold. The lower base is in metal mat gold finish. Available also with top in marble White silk matt.

A

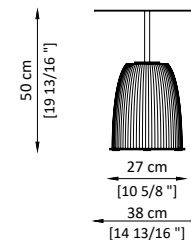

A | TAV.DION.110

Mat brass top - 3D Ceramic base

B

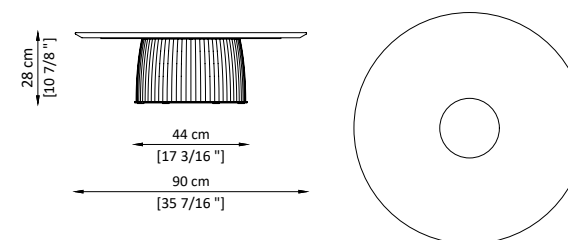

WHITE SILK | TAV.DION.121

Marble top White Silk matt - mat brass details - 3D Ceramic base

CALACATTA | TAV.DION.120

Marble top Calacatta - mat brass details - 3D Ceramic base

C

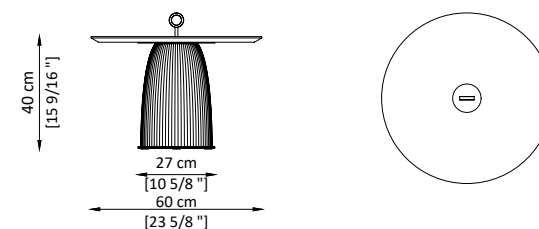

WHITE SILK | TAV.DION.131

Marble top White Silk matt - mat brass details - 3D Ceramic base

CALACATTA | TAV.DION.130

Marble top Calacatta - mat brass details - 3D Ceramic base



▲
**Ceramica artigianale realizzata
 e modellata a mano presso
 antichi laboratori a Vietri.**

Handmade artisan ceramic
 manually operated in antique
 Vietri laboratories.

Inspiration

C

CLAUDE COFFEE TABLE

DESIGN | VITTORIO PARADISO



A

B

C



Metal Finish
Polished Gold



Marble
Botanic Green

Alternative top options



Marble
Calacatta

L'ispirazione deriva dai famosi quadri "ninfee" dell'artista impressionista Claude Monet. Così è nata la serie di elementi di servizio, composta da tre varianti, da utilizzare come piano d'appoggio in numerose situazioni. Morbidezza e rigidità, accostamento di materiali a contrasto. Sono i dettagli che creano i movimenti impercettibili nell'andamento delle forme. Le basi in metallo con finitura oro lucido sorreggono mutevoli scorci di lago in marmo botanic green che si rastremano lievemente nella parte inferiore smussando la loro geometria; forme morbide, calibratissime, dettagli accurati.

The inspiration comes from the famous "water-lilies" paintings of the impressionist artist Claude Monet. This gave birth to the series of serving elements consisting of three variants to be used as trivets in various situations. Softness and rigidity, matching of contrasting materials. These are the details that create imperceptible movements in the progression of the forms. The metal bases in shiny gold finish support mutating glimpses of lake in botanic green marble which lightly taper off in the lower part, smoothing their geometry; soft forms, highly calibrated, fine details.

A

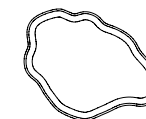
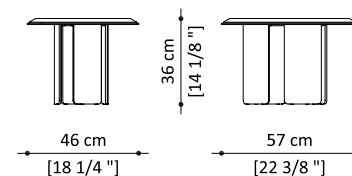

BOTANIC GREEN | TAV.CLAU.110

Metal base polished gold finished
Top marble Botanic Green

CALACATTA | TAV.CLAU.140

Polished gold finish base
Top marble Calacatta

B

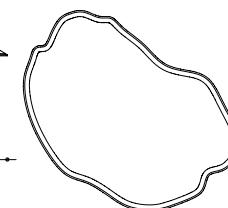
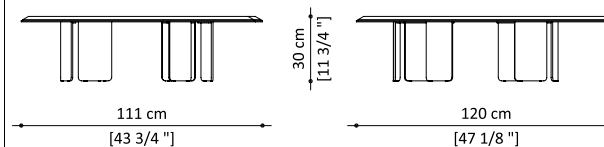

BOTANIC GREEN | TAV.CLAU.120

Metal base polished gold finished
Top marble Botanic Green

CALACATTA | TAV.CLAU.150

Polished gold finish base
Top marble Calacatta

C

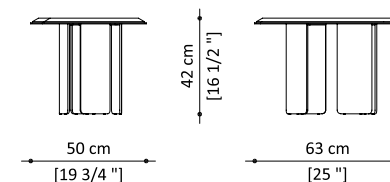

BOTANIC GREEN | TAV.CLAU.130

Metal base polished gold finished
Top marble Botanic Green

CALACATTA | TAV.CLAU.160

Polished gold finish base
Top marble Calacatta



◀ **Botanic green: pregiata
quarzite proveniente dal
Brasile di un intenso colore
verde brillante.**

Botanic green: brilliant green
Brazilian quartzite stone.

ELLE COFFEE TABLE

DESIGN | LUCA SCACCHETTI



RECTANGULAR

SQUARE 50

SQUARE 80



Metal Finish
Matt Gold



Bronze Mirrored
Glass Matt

Elle Collection Coffee Table è un tavolino basso ideale per arredare salotti e zone living, nelle due proposte quadrata e rettangolare. La struttura è in metallo con finitura oro opaco satinato e top realizzato in vetro specchiato satinato color bronzo.

Elle Collection Coffee Table is a low table ideal in sitting rooms and living rooms, offered in both square and rectangular versions. The structure is made in metal with mat gold finishing, top is made in bronze mirrored glass matt.

SQUARE 50

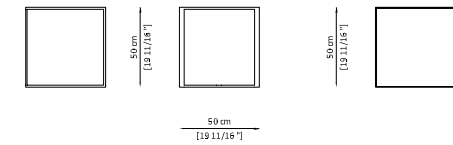

BRONZE MIRRORED GLASS | TAV.ELLE.132

Bronze mirrored glass mat top - metal base mat gold finished

SQUARE 80

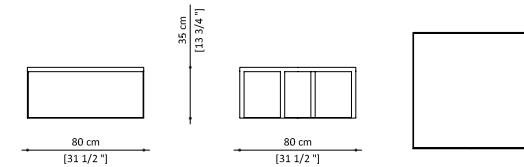

BRONZE MIRRORED GLASS | TAV.ELLE.112

Bronze mirrored glass mat top - metal base mat gold finished

RECTANGULAR

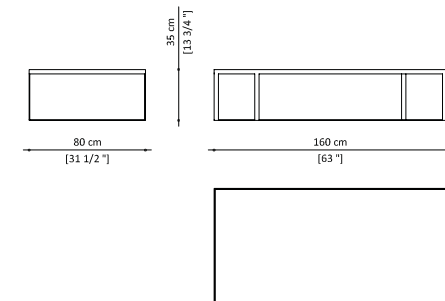

RECTANGULAR | TAV.ELLE.122

Bronze mirrored glass mat top - metal base mat gold finished

IMPERFECT COFFEE TABLE

DESIGN | PAOLO CASTELLI

GLASS

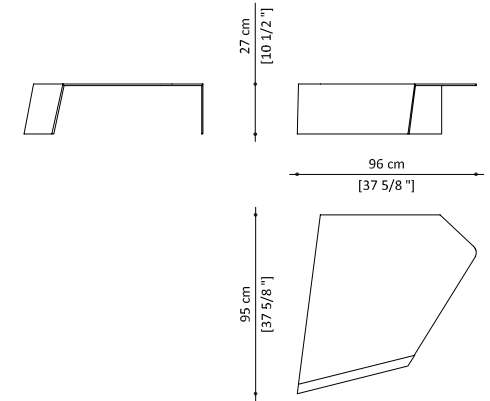

GLASS | TAV.IMPE.120
Mirrored Bronze glass

MARBLE

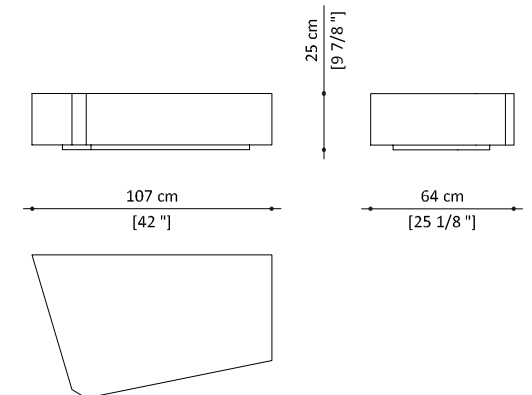

PECE STONE | TAV.IMPE.111
Pece stone

ROSA EGEO | TAV.IMPE.110
Marble Rosa Egeo



SIDE

GLASS

MARBLE

METAL

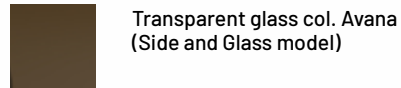
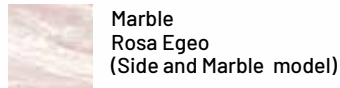

GLASS - Tavolino composto da lastre di vetro con sfumatura metallizzata fatta a mano, che ha la caratteristica di essere sfumato dal trasparente allo specchiato.

MARBLE- Tavolino in marmo con struttura in legno, rivestito con lastre di marmo Rosa Egeo o in pietra Pece. Zoccolo realizzato in legno impiallacciato tinto scuro.

GLASS - Coffee table made by reflective bronze glass plates, it has the characteristic of a gradient from transparent to mirrored.

MARBLE- marble coffee table with wooden frame covered with marble slabs Rosa Egeo or Pece stone. Hidden base made of dark stained veneered wood.

IMPERFECT COFFEE TABLE

DESIGN | PAOLO CASTELLI



SIDE

GLASS

STONE

METAL



Metal Finish Polished Gold
(Side and Metal model)



Pece Stone
(Side and Marble model)



Transparent glass col. Avana
(Side and Glass model)

METAL SHINE GOLD- Tavolino realizzato con 3 lastre di metallo spessore 8mm, posizionate ad incastro, in finitura oro lucido.

SIDE- Tavolino realizzato con 3 lastre in materiali diversi - marmo Rosa Egeo, metallo con finitura oro lucido, vetro color Avana - combinati tra loro e posizionati ad incastro.

METAL SHINE GOLD - Coffee table made of 3 metal sheets 8mm thick, positioned interlocking, in polished gold finish.

SIDE - Coffee table made by 3 sheets of different materials - Marble Rosa Egeo, metal with finish gold gloss, transparent Avana glass - combined and placed interlocked.

METAL SHINE GOLD

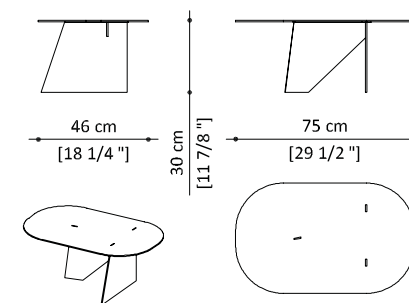

METAL SHINE GOLD | TAV.IMPE.130

Metal polished gold finish

SIDE

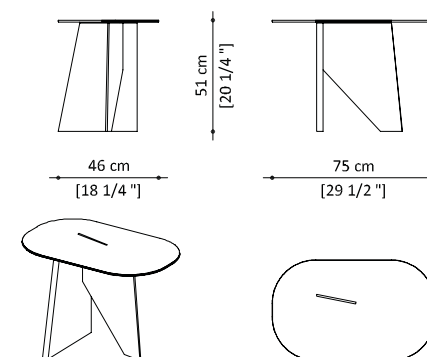

PECE STONE | TAV.IMPE.141

Glass col. Avana top
Base made in Pece Stone and metal polished gold

ROSA EGEO | TAV.IMPE.140

Glass col. Avana top
Base made in Rosa Egeo marble and metal polished gold



◀ Raffinati accostamenti di materiali nobili.

Noble materials tastefully juxtaposed.

NETTUNO COFFEE TABLE

DESIGN | VITTORIO PARADISO



L105

L120



Metal Finish
Polished Bronze
Shadow Striped



Bronze Mirrored
Glass Matt



Transparent
glass col. Avana
Satin

Alternative base option



Metal Finish
Polished Gold
Striped

Alternative top options



Glass
Grey
Brown



Glass
Amaranth

Collezione di tavolini caratterizzati da una sofisticata semplicità delle linee, declinata in una scelta di materiali di grande pregio per suggerire un modo diverso di pensare lo spazio abitato. Top in vetro bronzato con un lato parzialmente specchiato, o in alternativa retrolaccato, base in metallo plissettato finitura lucida bronze shadow o oro.

Collection of coffee tables featuring a sophisticated simplicity of lines, offered with a choice of high quality materials to present a different way of conceiving a living space. Top in bronzed glass with one side partially mirrored (also available the backlaquered glass top) base in pleated metal with a polished finish bronze shadow or gold.

L105

backlaquered glass top

bronzed mirrored glass top

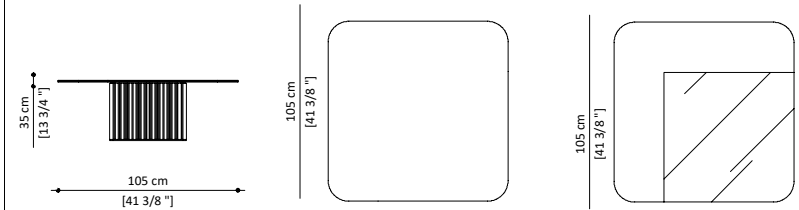

L105 BACKLAQUERED GLASS | TAV.NETT.120

Backlaquered glass top - Brown 100gloss RAL8019 - Amaranth RAL 3007
Plissé metal base, polished gold finish or bronze shadow.

L105 BRONZED GLASS | TAV.NETT.121

Bronzed glass top with mirrored insert
Plissé metal base, polished gold finish or bronze shadow.

L120

backlaquered glass top

bronzed mirrored glass

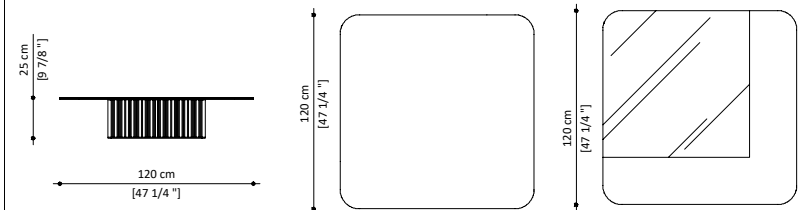

L120 BACKLAQUERED GLASS | TAV.NETT.110

Backlaquered glass top - Brown 100gloss RAL8019 - Amaranth RAL 3007
Plissé metal base, polished gold finish or bronze shadow.

L120 BRONZED GLASS | TAV.NETT.111

Bronzed glass top with mirrored insert
Plissé metal base, polished gold finish or bronze shadow.



C



◀ **Top in vetro bronzato con un lato parzialmente specchiato.**

Top in bronzed glass partially mirrored.

RIBBON COFFEE TABLE

DESIGN | PAOLO CASTELLI



Alternative top options



Una sinfonia di linee ondulate in ottone verniciato opaco, che sorreggono un piano, in mdf laccato con preziosa finitura Saffiano a più strati o in marmo Black Sahara, oppure con piano in vetro retrolaccato. I tavolini Ribbon coffee table sono pensati come elementi di servizio alla zona living, inoltre sono facilmente adattabili a contesti differenti grazie alla loro misurata eleganza e alla pluralità di forme e altezze disponibili.

A symphony of undulating lines in matt varnished brass supporting a mdf lacquered top with Saffiano finishing or a marble top in Black Sahara, or backlaquered glass top.

The Ribbon coffee tables are designed as service elements in the living area, while they are easily adaptable to different contexts thanks to their measured elegance and the plurality of available forms and heights.

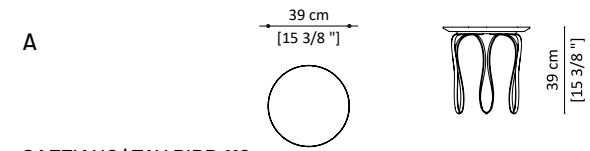

SAFFIANO | TAV.RIBB.110

Base in brass matt finish - Lacquered top Saffiano finish 100 gloss
Available colours: Bronze, Orange, Green, Bordeaux

BLACK SAHARA | TAV.RIBB.111

Base in brass matt finish
Black Sahara marble top

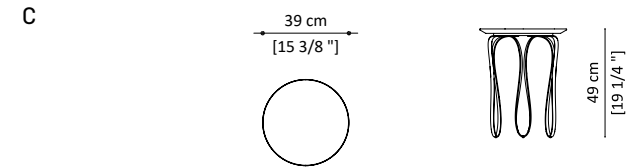

SAFFIANO | TAV.RIBB.130

Base in brass matt finish - Lacquered top Saffiano finish 100 gloss
Available colours: Bronze, Orange, Green, Bordeaux

BLACK SAHARA | TAV.RIBB.131

Base in brass matt finish
Black Sahara marble top

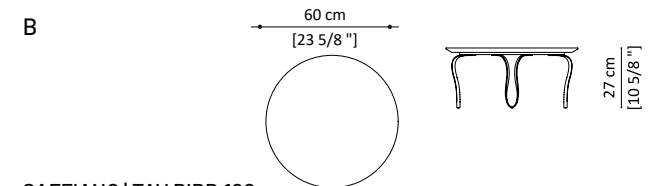

SAFFIANO | TAV.RIBB.120

Base in brass matt finish - Lacquered top Saffiano finish 100 gloss
Available colours: Bronze, Orange, Green, Bordeaux

BLACK SAHARA | TAV.RIBB.121

Base in brass matt finish
Black Sahara marble top

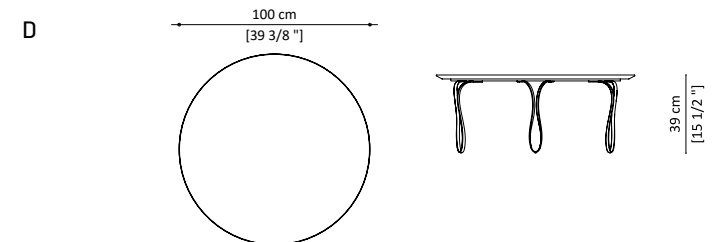

SAFFIANO | TAV.RIBB.140

Base in brass matt finish - Lacquered top Saffiano finish 100 gloss
Available colours: Bronze, Orange, Green, Bordeaux

RIBBON GLASS COFFEE TABLE

DESIGN | PAOLO CASTELLI



A

B

C

D



Matt Brass



Glass Brown



Glass Amaranth

Una sinfonia di linee ondulate in ottone verniciato opaco, che sorreggono un piano, in mdf laccato con preziosa finitura Saffiano a più strati o in marmo Black Sahara, oppure con piano in vetro retrolaccato. I tavolini Ribbon coffee table sono pensati come elementi di servizio alla zona living, inoltre sono facilmente adattabili a contesti differenti grazie alla loro misurata eleganza e alla pluralità di forme e altezze disponibili.

A symphony of undulating lines in matt varnished brass supporting a mdf lacquered top with Saffiano finishing or a marble top in Black Sahara, or backlaquered glass top.

The Ribbon coffee tables are designed as service elements in the living area, while they are easily adaptable to different contexts thanks to their measured elegance and the plurality of available forms and heights.

A

39 cm
[15 3/8"]

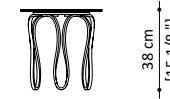

38 cm
[15 1/8"]

BACKLAQUERED GLASS | TAV.RIBB.110G

Base in brass matt finish

Backlaquered glass top - Brown 100gloss RAL8019 - Amaranth RAL 3007

C

39 cm
[15 3/8"]

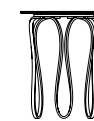

48 cm
[19"]

BACKLAQUERED GLASS | TAV.RIBB.130G

Polished gold finish base - Backlaquered glass top

Backlaquered glass top - Brown 100gloss RAL8019 - Amaranth RAL 3007

B

60 cm
[23 5/8"]

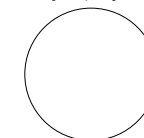

26 cm
[10 3/8"]

BACKLAQUERED GLASS | TAV.RIBB.120G

Polished gold finish base - Backlaquered glass top

Backlaquered glass top - Brown 100gloss RAL8019 - Amaranth RAL 3007

D

100 cm
[39 3/8"]

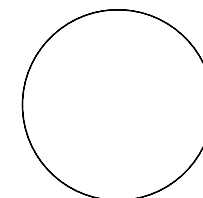

38 cm
[15 1/8"]

BACKLAQUERED GLASS | TAV.RIBB.140G

Polished gold finish base - Backlaquered glass top

Backlaquered glass top - Brown 100gloss RAL8019 - Amaranth RAL 3007

Gambe in ottone lavorate e curvate manualmente una ad una.

Brass legs shaped by hand one by one.





TIMBUCTU SIDE TABLES

DESIGN | SAMUELE MAZZA



Ø65

Ø80



Noto
Stone
(top model 65)



Pece
Stone
(top model 80)



Metal Finish
Bronze
Shadow Matt



Nabuk twisted
Col. 02
Dark Brown

Ø65: tavolino da salotto con piano di forma rotonda, realizzato in pietra di Noto color Beige. La struttura a quattro gambe è in metallo con finitura Bronze Shadow Opaco, rivestite in nabuk con motivo intrecciato col. marrone scuro cod. 02.

Ø80: tavolino da salotto con piano di forma rotonda, realizzato in pietra Pece color marrone. La struttura a quattro gambe è in metallo con finitura Bronze Shadow Opaco, rivestite in nabuk con motivo intrecciato colorato in tinta col. marrone scuro cod. 02.

Ø65: coffee table with round shaped top, made of beige Noto stone. The four-leg frame is made of metal with a Bronze Shadow matt finish, covered in Nabuck, with a matching colored braided pattern - coloured dark browk cod. 02.

Ø80: coffee table with round shaped top, made of brown Pece stone. The four-leg frame is made of metal with a Bronze Shadow matt finish, covered in nubuck with a matching colored braided pattern - dark browk cod. 02.

Ø65

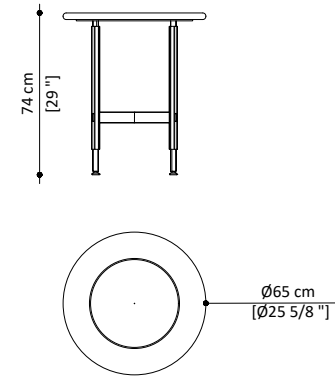

Ø65 |TAV.TIMB.130

Pece stone top

Metal base - finish Bronze Shadow Matt with interwooven pattern Nabuk details col. 02 Dark brown

Ø80

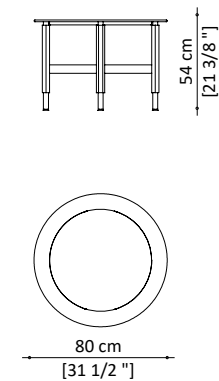

Ø80 |TAV.TIMB.120

Pece stone top

Metal base - finish Bronze Shadow Matt with interwooven pattern Nabuk details col. 02 Dark brown



C



◀ **Gambe rivestite in nabuk a motivo intrecciato.**

Legs upholstered in nubuck with twist texture.

TIMBUCTU COFFEE TABLE

DESIGN | SAMUELE MAZZA



Noto
Stone



Wood
Elm Grey



Metal Finish
Bronze
Shadow Mat



Nabuk twisted
Col. 02
Dark Brown

Tavolo da salotto dalle dimensioni importanti e dalla forma insolita a canoa, realizzato in legno finitura Olmo cenere. La struttura a quattro gambe con traversi è in metallo con finitura Bronze Shadow Opaco, rivestite in nabuk con stampa a motivo intrecciato colorato in tinta col. marrone scuro cod. 02. A richiesta è disponibile il vassoio ovale in pietra di Noto da disporre in appoggio sul piano.

A large size table with an unusual canoe shape, made of ash elm wood. The four legs frame with crosspieces is made of metal with a Bronze Shadow Opaque finish, legs are covered in Nabuck, with a matching colored braided pattern - dark brown cod. 02. On request the oval tray made of Noto stone is available to be placed on the top.

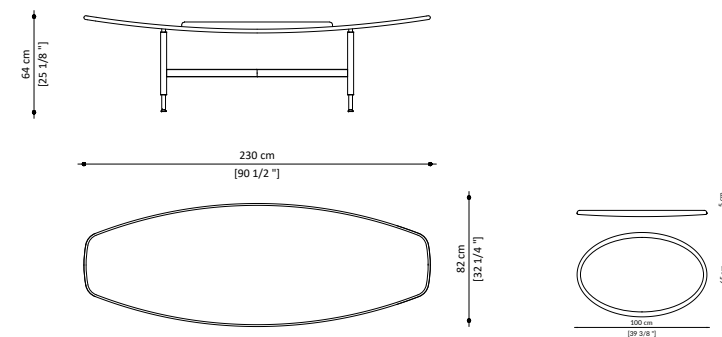

COFFEE TABLE | TAV.TIMB.110

Ash elm wooden top
Metal base - finish Bronze Shadow Mat with interwooven pattern Nabuk details col. 02 Dark Brown

OPTIONAL TRAY IN NOTO STONE | COM.TRAY.TIM.001

Noto stone top



SUEZ COFFEE TABLE

DESIGN | SAMUELE MAZZA



L 90

L 120

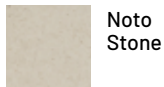

Noto
Stone



Pece
Stone



Metal Finish
Bronze
Shadow Matt



Nabuk twisted
Col. 02
Dark Brown

L90: tavolino con piano in pietra Pece color marrone con bordi arrotondati. Struttura in metallo a 3 gambe, con finitura Bronze Shadow Opaco, rivestite in nabuk con stampa a motivo intrecciato colorato in tinta col. marrone scuro cod. 02.

L120: tavolino con piano in pietra di Noto color Beige con bordi arrotondati. Struttura in metallo a 3 gambe, con finitura Bronze Shadow Opaco, rivestite in nabuk con stampa a motivo intrecciato col. marrone scuro cod. 02.

L90: coffee table with brown Pece stone top with rounded edges. Metal frame with 3 legs, Bronze Shadow Matt finish, covered in nubuck with interwoven pattern printed, coloured in the same color of the stone top - dark brown cod. 02.

L120: coffee table with beige Noto stone top with rounded edges. Metal frame with 3 legs, Bronze Shadow Matt finish, covered in nubuck with interwoven pattern printed, coloured dark brown cod. 02.

L 90

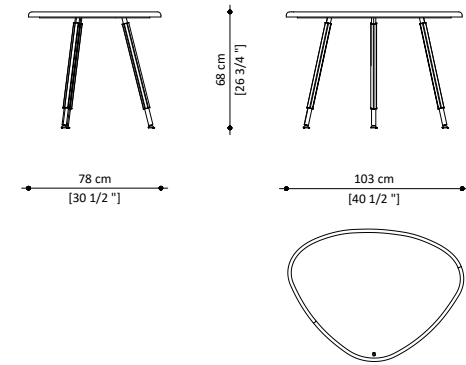

L 90 | TAV.SUEZ.110

Pece stone top
Metal base - finish Bronze Shadow Matt with twisted pattern Nabuk details col. 02 Dark Brown

L 120

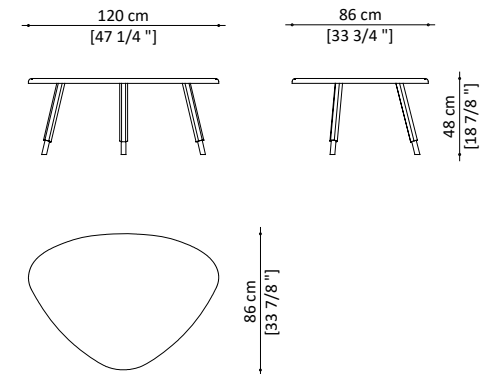

L 120 | TAV.SUEZ.120

Noto stone top
Metal base - finish Bronze Shadow Matt with twisted pattern Nabuk details col. 02 Dark Brown



Inspiration



PROFESSOR PLUM

DESIGN | CRISTIANO GATTO DESIGN



H30

H46



Marble
Black Sahara



Metal Finish
Matt Bronzed
Brass

Monolitici elementi geometrici, a sezione esagonale, in altezze differenti, realizzati in marmo. La base è in legno rivestita con profilo metallico con finitura bronzo ottone opaco. E' realizzato in marmo Black Sahara ricavato da pieno.

Monolithic geometric elements in a hexagonal shape, different heights made of marble. The wooden base is covered with a metallic enriched with a mat bronze finish.

The marble model is made of whole Black Sahara marble.

H 30

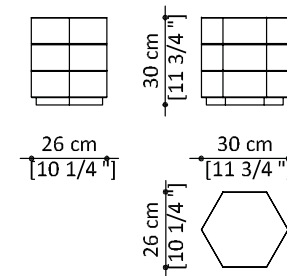

H 30 | TAV.PPLU.110

Marble Black Sahara

H 46

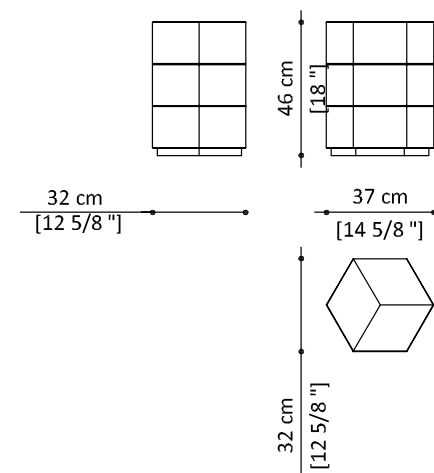

H 46 | TAV.PPLU.111

Marble Black Sahara

Inspiration
THE HOUSE OF ELEGANCE

C



PAOLO CASTELLI

SEDUTE CHAIRS

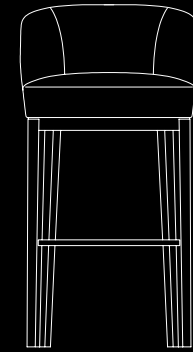
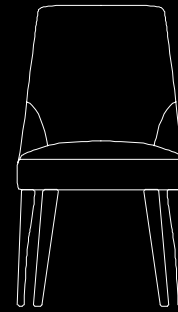
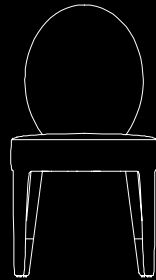
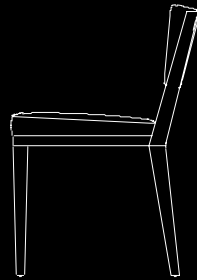
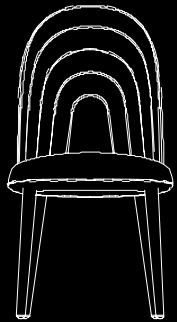

Inspiration



SOFIA CHAIR

DESIGN | PAOLO CASTELLI



Polished
brass



Fabric Superior
Velvet Sig
Col. 42 Green

Sofia è una sofisticata e confortevole seduta che rivisita, nelle sue forme, il design degli anni '30, per adattarsi ad ogni contesto abitativo o spazio collettivo con uno spiccato appeal estetico.

La seduta ha un telaio in legno multistrato curvato e imbottitura in poliuretano espanso sagomato a quote differenziate, mentre le gambe in legno di faggio sono rivestite nel medesimo rivestimento con un prezioso puntale in ottone lucido nelle gambe posteriori. Sofia è interamente rivestita in pregiati velluti non sfoderabili, pelle bovine e nabuk. Sofia è disponibile nel modello con e senza braccioli. Non sfoderabile.

Sofia is a sophisticated and comfortable chair, with a shape reminiscent of the design of the 1930s, which adapts to every living context or collective space with a high level of visual appeal.

Its structure is made of curved multi-layer wood, padded in different density expanded polyurethane, while the legs are beech wood and have the same upholstery as the chair. The back legs feature a metal insert in polished brass. Sofia can be completely upholstered in nonremovable elegant velvets, fine leather or nubuck. Sofia is available in both without and with armrests. Unremovable covering.

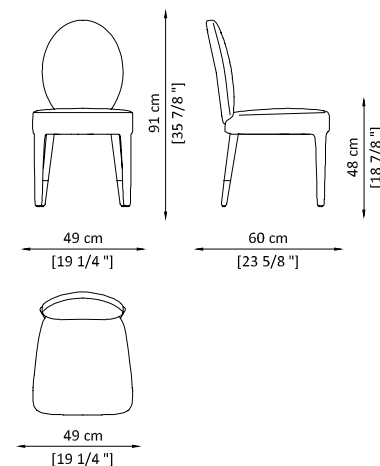

ECOLEATHER | SED.SOFI.700.ECO

Polished gold feet
Eco-Friendly Leather

VELVET SUPERIOR | SED.SOFI.700.SUP

Polished gold feet
Velvet Superior

LEATHER | SED.SOFI.700.PEL

Polished gold feet
Bovine Leather

NABUK | SED.SOFI.700.NAB

Polished gold feet
Nabuk



C



Inspiration

C

SOFIA WITH ARMS

DESIGN | PAOLO CASTELLI



Polished
brass



Fabric Superior
Velvet Sig
Col. 20 Bordeaux

Sofia è una sofisticata e confortevole seduta che rivisita, nelle sue forme, il design degli anni '30, per adattarsi ad ogni contesto abitativo o spazio collettivo con uno spiccato appeal estetico.

La seduta ha un telaio in legno multistrato curvato e imbottitura in poliuretano espanso sagomato a quote differenziate, mentre le gambe in legno di faggio sono rivestite nel medesimo rivestimento con un prezioso puntale in ottone lucido nelle gambe posteriori. Sofia è interamente rivestita in pregiati velluti non sfoderabili, pelle bovine e nabuk. Sofia è disponibile nel modello con e senza braccioli. Non sfoderabile.

Sofia is a sophisticated and comfortable chair, with a shape reminiscent of the design of the 1930s, which adapts to every living context or collective space with a high level of visual appeal.

Its structure is made of curved multi-layer wood, padded in different density expanded polyurethane, while the legs are beech wood and have the same upholstery as the chair. The back legs feature a metal insert in polished brass. Sofia can be completely upholstered in nonremovable elegant velvets, fine leather or nubuck. Sofia is available in both without and with armrests. Unremovable covering.

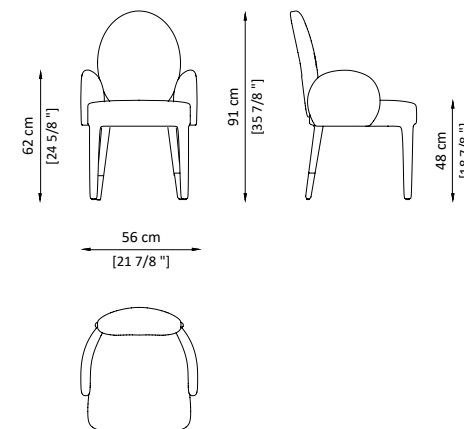

ECOLEATHER | SED.SOFI.710.ECO

Polished gold feet
Eco-Friendly Leather

VELVET SUPERIOR | SED.SOFI.710.SUP

Polished gold feet
Velvet Superior

LEATHER | SED.SOFI.710.PEL

Polished gold feet
Bovine Leather

NABUK | SED.SOFI.710.NAB

Polished gold feet
Nabuk



Inspiration

C

AUDREY CHAIR

DESIGN | PAOLO CASTELLI



Wood Painted
Matt Gold

Fabric Deluxe
Lampasso
Col. 12 Saffron

Le linee morbide e fluide sono i tratti distintivi della seduta Audrey, ideata per arredare con eleganza la zona dining offrendo al contempo un ottimo comfort. La seduta ha una struttura realizzata in legno di faggio con soffice imbottitura in poliuretano espanso sagomato a quote differenziate, con pre-rivestimento in cotone 100% e ovatta di poliestere. Il rivestimento è personalizzabile con eleganti tessuti, pelli bovine e nabuk, mentre le gambe sono in legno di faggio verniciato color oro opaco. Non sfoderabile.

Soft, fluid lines are the distinctive characteristics of this seat, designed to bring elegance to the dining area while offering maximum comfort at the same time. The chair has a beech wood structure, padded in different density expanded polyurethane, covered on the inside with 100% cotton and polyester. The upholstery can be personalized choosing elegant fabric, fine leather or nubuck; the legs are beech wood and are painted matt gold. Unremovable covering.

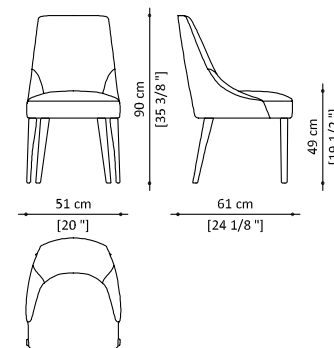

ECOLEATHER | SED.AUDR.720.ECO

Wooden legs matt gold painted
Eco-Friendly Leather

FABRIC SUPERIOR | SED.AUDR.720.SUP

Wooden legs matt gold painted
Fabric Superior

FABRIC DELUXE | SED.AUDR.720.DEL

Wooden legs matt gold painted
Fabric Deluxe

LEATHER | SED.AUDR.720.PEL

Wooden legs matt gold painted
Bovine Leather

NABUK | SED.AUDR.720.NAB

Wooden legs matt gold painted
Nabuk



C



AUDREY WITH ARMS

DESIGN | PAOLO CASTELLI



Wood Painted
Matt Gold



Fabric Deluxe
Lampasso
Col. 01 Stone

Le linee morbide e fluide sono i tratti distintivi della seduta Audrey, ideata per arredare con eleganza la zona dining offrendo al contempo un ottimo comfort. La seduta ha una struttura realizzata in legno di faggio con soffice imbottitura in poliuretano espanso sagomato a quote differenziate, con pre-rivestimento in cotone 100% e ovatta di poliestere. Il rivestimento è personalizzabile con eleganti tessuti, pelli bovine e nabuk, mentre le gambe sono in legno di faggio verniciato color oro opaco. Non sfoderabile.

Soft, fluid lines are the distinctive characteristics of this seat, designed to bring elegance to the dining area while offering maximum comfort at the same time. The chair has a beech wood structure, padded in different density expanded polyurethane, covered on the inside with 100% cotton and polyester. The upholstery can be personalized choosing elegant fabric, fine leather or nubuck; the legs are beech wood and are painted matt gold. Unremovable covering.

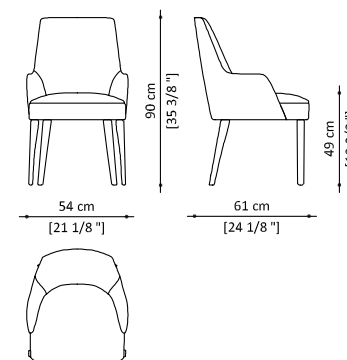

ECOLEATHER | SED.AUDR.710.ECO

Wooden legs matt gold painted
Eco-Friendly Leather

FABRIC SUPERIOR | SED.AUDR.710.SUP

Wooden legs matt gold painted
Fabric Superior

FABRIC DELUXE | SED.AUDR.710.DEL

Wooden legs matt gold painted
Fabric Deluxe

LEATHER | SED.AUDR.710.PEL

Wooden legs matt gold painted
Bovine Leather

NABUK | SED.AUDR.710.NAB

Wooden legs matt gold painted
Nabuk



CE



Inspiration



ECHO CHAIR

DESIGN | PAOLO CASTELLI

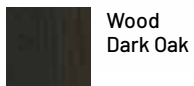

Wood
Dark Oak



Nabuck
Col. 34 Wine

Sedia di impianto classico e di comode proporzioni, le cui forme fluide invitano a piacevoli conversazioni. Struttura in multistrato curvato con gambe rastremate in legno di rovere tinto scuro, imbottitura in poliuretano espanso sagomato a quote differenziate. Lo schienale imbottito trapuntato con motivo ad archi richiama le suggestioni prospettiche dei portici bolognesi. Rivestimento disponibile in pregiati tessuti, pelli bovine e nabuk. Non sfoderabile.

Classical, comfortably sized chair with fluid shapes that just invite pleasant conversations. Curved plywood frame with tapered legs in dark stained oak, padded in different density expanded polyurethane. The backrest, padded with arches pattern, brings to mind the intriguing perspective of the porticoes of Bologna. Covers are available in elegant fabric, fine leathers or nabuk. Unremovable covering.

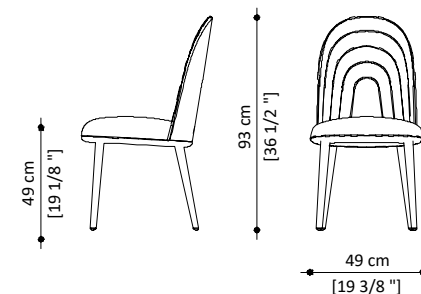

ECOLEATHER | SED.ECHO.700.ECO

Base in oak finish
Eco-Friendly Leather

FABRIC SUPERIOR | SED.ECHO.700.SUP

Base in oak finish
Fabric Superior

FABRIC DELUXE | SED.ECHO.700.DEL

Base in oak finish
Fabric Deluxe

LEATHER | SED.ECHO.700.PEL

Base in oak finish
Bovine Leather

NABUK | SED.ECHO.700.NAB

Base in oak finish
Nabuk



◀ Schienale imbottito a fasce ondulate.

Back padded with wavy bands.

Inspiration



STRAPUNTINO CHAIR

DESIGN | PAOLO CASTELLI

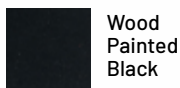

Wood
Painted
Black



Nabuk twisted
Col. 15 Taupe



Matt
Brass

Questa sedia riassume in sé l'essenza del design contemporaneo e la memoria della tradizione. Telaio, essenziale nel disegno ma raffinato nelle proporzioni, in faggio laccato nero opaco con preziosi dettagli in ottone satinato opaco, che garantiscono il fascino a questa seduta estremamente versatile. Imbottitura in poliuretano espanso sagomato a quote differenziate. Rivestimento disponibile in pregiati tessuti, pelli bovine e nabuk. Non sfoderabile.

This chair embodies the very essence of contemporary design and the memory of tradition. The frame, simple in its design but refined in its proportions, is in matt black lacquered beech with fine details in matt satin finish brass, which guarantee the charm of this extremely versatile seat. Padding in different density expanded polyurethane. Covers are available in elegant fabric, fine leathers or nabuk. Unremovable covering.

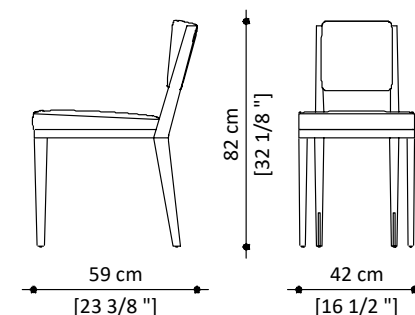

ECOLEATHER | SED.TRAI.700.ECO

Base mat black lacquered beech
Eco-Friendly Leather

FABRIC SUPERIOR | SED.TRAI.700.SUP

Base mat black lacquered beech
Fabric Superior

FABRIC DELUXE | SED.TRAI.700.DEL

Base mat black lacquered beech
Fabric Deluxe

LEATHER | SED.TRAI.700.PEL

Base mat black lacquered beech
Bovine Leather

NABUK | SED.TRAI.700.NAB

Base mat black lacquered beech
Nabuk



C



◀ **Seduta compatta e dalle raffinate e insolite proporzioni.**

Solid seat characterised by refined and peculiar proportions.

Inspiration

C

N°5 LOW CHAIR

DESIGN | PAOLO CASTELLI

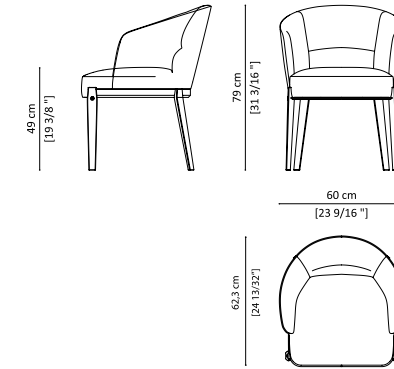

Wood
Dark Oak



Nabuk
Col. 15 Taupe



Matt
Brass

Linee avvolgenti e fluide per questa collezione di sedute imbottite dal grande comfort e dalla massima raffinatezza. Disponibile in due versioni: con seduta a pozzetto e con schienale alto.

LOW CHAIR: gambe in rovere tinto scuro, seduta a pozzetto con sedile e schienale imbottiti in poliuretano espanso sagomato a quote differenziate e rivestita in tessuto o pelle a campionario. Non sfoderabile.

Enveloping and fluid lines for this collection of highly comfortable upholstered chairs of optimal refinement. Available in two versions: with low and high back.

LOW CHAIR: dark stained oak legs, padded seat and back in different density expanded polyurethane, upholstered in fabric or sample leather. Not removable.

FABRIC SUPERIOR | SED.NUM5.710.SUP

Front & back fabric Superior

FABRIC DELUXE | SED.NUM5.710.DEL

Front & back fabric Deluxe

LEATHER | SED.NUM5.710.PEL

Front & back bovine leather

NABUK | SED.NUM5.710.NAB

Front & back nabuk



C



◀ **Confort e versatilità di utilizzo soprattutto in ambito contract.**

Ideal in contract commissions for his comfort and versatility.

Inspiration



N°5 HIGH CHAIR

DESIGN | PAOLO CASTELLI



Wood
Dark Oak



Nabuk
Col. 15 Taupe



Matt
Brass

Linee avvolgenti e fluide per questa collezione di sedute imbottite dal grande comfort e dalla massima raffinatezza. Disponibile in due versioni: con seduta a pozzetto e con schienale alto.

HIGH CHAIR: struttura in rovere tinto scuro, seduta schienale in legno di rovere tinto scuro, seduta imbottita in poliuretano espanso sagomato a quote differenziate e rivestita in tessuto o pelle a campionario. Impreziosisce il disegno un pregiata maniglia decorativa in pelle e ottone opaco, posizionata sul retro dello schienale. Non sfoderabile.

Enveloping and fluid lines for this collection of highly comfortable upholstered chairs of optimal refinement. Available in two versions: with low and high back.

HIGH CHAIR: dark stained oak structure, dark-stained oak backrest seat, padded seat and back in different density expanded polyurethane, upholstered in fabric or sample leather. The design is enhanced by a high-quality decorative handle in opaque brass and leather positioned on the back of the back. Not removable.

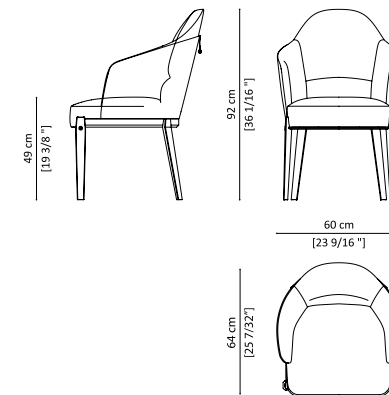

FABRIC SUPERIOR | SED.NUM5.720.SUP

Front in fabric Superior and back in oak wood

FABRIC DELUXE | SED.NUM5.720.DEL

Front in fabric Deluxe and back in oak wood

LEATHER | SED.NUM5.720.PEL

Front in bovine leather and back in oak wood

NABUK | SED.NUM5.720.NAB

Front nabuk and back in oak wood



Inspiration



EMPIRE CHAIR

DESIGN | PAOLO CASTELLI

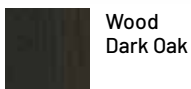

Wood
Dark Oak



Leather
Col. Dark Brown



Metal Finish
Matt Gold

Una sedia polimerica che profuma di viaggi esotici alla ricerca di un Eden perduto. Ispirata allo stile coloniale lo schienale e la seduta sono rivestiti in cuoio, mentre la ricercatezza della lavorazione della struttura in rovere tinto scuro è esalta dal contrasto cromatico e materico dei preziosi inserti in metallo con finitura oro opaco.

A multi-materic chair with the scent of exotic voyages in search of a lost Eden. Inspired by the colonial style, the back and seat are covered in leather, whereas the refinement of the working of the structure in dark stained oak is highlighted by the chromatic and materic contrast of precious inserts in metal matt gold finish.

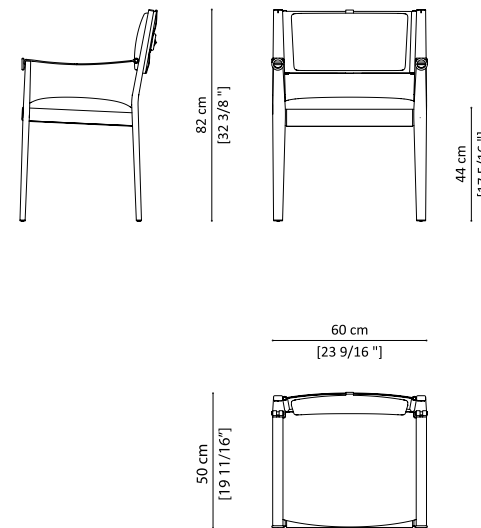

EMPIRE | SED.EMPI.710.PEL

Wooden structure dark stained oak, emery leather, metal details in matt gold finish



C



◀ **Ispirazione coloniale e preziosi dettagli dorati.**

Colonial inspiration with precious golden details.

Inspiration

C

GINEVRA CHAIR

DESIGN | GIAMPIERO PELA



Metal Finish
Chrome



Bovine Leather
Col. 661 Cuoio

Poltroncina elegante ed accogliente su base girevole, Ginevra è un tocco di classe per il soggiorno e perfetta abbinata a tavoli da pranzo e da riunione. La seduta ha una base girevole in acciaio inox cromato ed una scocca in legno multistrato curvato imbottita in poliuretano espanso sagomato a quote differenziate con pre-rivestimento in cotone 100% e ovatta di poliestere. Il rivestimento è in ecopelle o pelle bovina pieno fiore, non sfoderabile.

An elegant and light swivel chair, Ginevra brings a touch of class to the living room and is perfect around a dinner or a meeting table. It has a stainless steel swayable base and a curved multi-layer wood structure, padded with molded different density expanded polyurethane with an inside cover made of 100% cotton and polyester. The Ginevra chair can be upholstered in fine leather or ecoleather, non-removable.

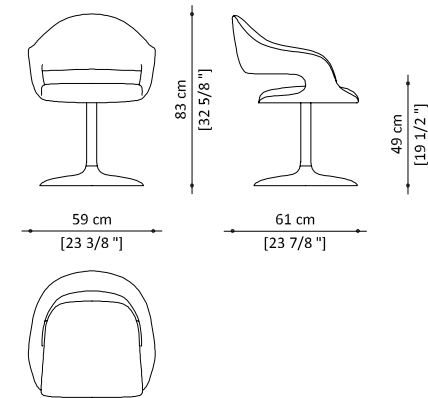

ECOLEATHER | SED.GINE.700.ECO

Chromed base
Eco-Friendly Leather

LEATHER | SED.GINE.700.PEL

Chromed base
Bovine Leather

NABUK | SED.GINE.700.NAB

Chromed base
Nabuk

Inspiration



VENICE STOOL

DESIGN | PAOLO CASTELLI

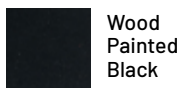

Wood
Painted
Black



Metal Finish
Black Nichel
Matt



Metal Finish
Polished Brass
(footrest)



Leather
Col. 603
Light Grey

Elegante e versatile sgabello, adatto per cocktail bar e per ambienti domestici.
Ha una struttura interna in multistrato di legno curvato con imbottitura in poliuretano a densità variabile.
Rivestimento non sfoderabile personalizzabile con pregiati tessuti, raffinate pelli bovine pieno fiore e nabuk. La seduta poggia su una struttura in legno di faggio verniciato nero opaco con poggia piedi in metallo finitura nichel nero con frontale in ottone lucido.

Stool with enveloping lines and high-backed which expands the Venice collection.
Suitable for the living room as for the night zone, is characterized by an internal structure in curved wood with padding in variable-density polyurethane-finishing. It has a non-removable cover customizable with fine fabrics, fine full-grain leather and nabuk finishing. The seat rests on a bleach wooden frame mat black lacquered, footrest in metal - nichel finish with polished brass insert.

STOOL H72

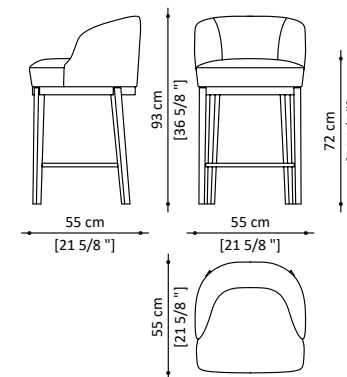

STOOL H85

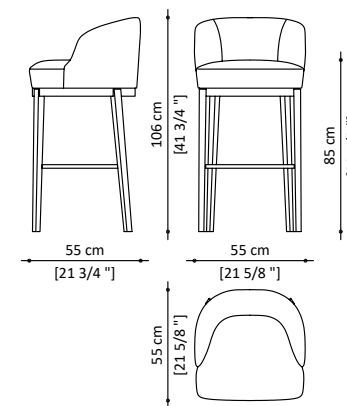

STOOL H72 / H85
ECOLEATHER | SED.VENI.810.ECO / SED.VENI.800.ECO
Black mat varnished legs - Eco-Friendly Leather

FABRIC SUPERIOR | SED.VENI.810.SUP / SED.VENI.800.SUP
Black mat varnished legs - Fabric Deluxe

FABRIC DELUXE | SED.VENI.810.DEL / SED.VENI.800.DEL
Black mat varnished legs - Fabric Deluxe

LEATHER | SED.VENI.810.PEL / SED.VENI.800.PEL
Black mat varnished legs - Leather

NABUK | SED.VENI.810.NAB / SED.VENI.800.NAB
Black mat varnished legs - Nabuk

Inspiration
THE HOUSE OF ELEGANCE



PAOLO CASTELLI

DIVANI
SOFAS

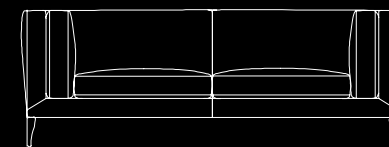
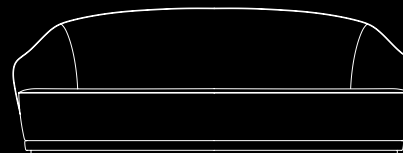
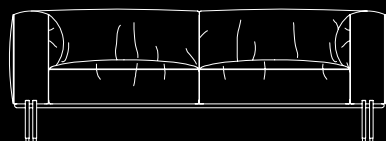
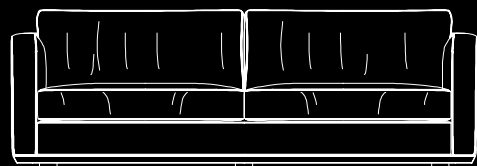

Inspiration



LEMMA SOFA

DESIGN | PAOLO CASTELLI



Fabric Superior
Velvet Sig col. 29
Beige

Lemma Sofa ha struttura in legno con sistema di molleggio a cinghie elastiche imbottito con poliuretano espanso sagomato a quote differenziate. È provvisto di zoccolo in legno rivestito con il medesimo rivestimento. Il rivestimento, non sfoderabile, può essere personalizzato con morbidi velluti e cuscini decorativi. Possibilità di rivestire lo schienale a contrasto, anche con tessuti decorativi. Il rivestimento è realizzato con piping in tinta che impreziosisce ed esalta la linea del divano.

Its wooden structure features a suspension system of elastic bands, with different density expanded polyurethane stuffing. Its base is made of wood covered with the same materials. The non-removable cover can be personalised with soft velvet fabric and decorative cushions. The back can be upholstered in a contrasting colour even with decorative fabrics.

The upholstery is made with matching piping that embellishes and enhances the sofa line.

LEMMA SX - also available dx model

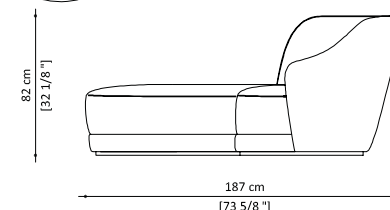
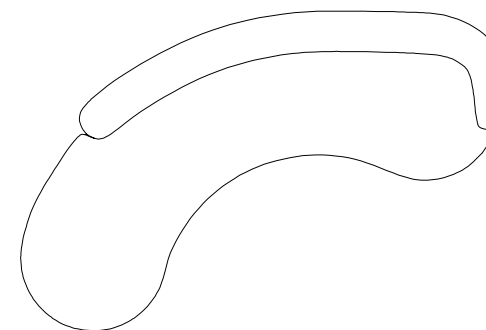
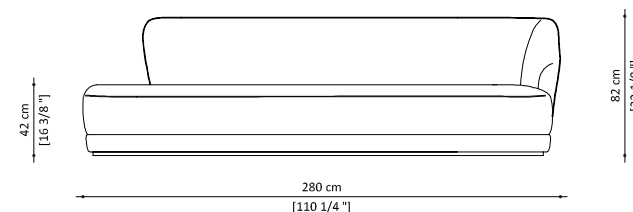

SX / DX
VELVET SUPERIOR | SED.LEMM.110.SUP / SED.LEMM.120.SUP
Fabric Velvet Superior

VELVET DELUXE | SED.LEMM.110.DEL / SED.LEMM.120.DEL
Fabric Velvet Deluxe

NABUK | SED.LEMM.110.NAB / SED.LEMM.120.NAB
Nabuk



◀ Lo sviluppo delle proporzioni è definito dall'applicazione della sezione aurea.

Golden ratio develops the proportions of this sofa.



Inspiration

C

LEMMA SIMMETRIC

DESIGN | PAOLO CASTELLI



Fabric Superior
Velvet Sig Col. 48
Grey

La versione a 3 posti ha un andamento simmetrico ed è una seduta da conversazione ideale per zone living, pubbliche e private, capace di creare un ambiente movimentato ed insolito.

Lemma Simmetric ha struttura in legno con sistema di molleggio a cinghie elastiche imbottito con poliuretano espanso sagomato a quote differenziate.

È provvisto di zoccolo in legno rivestito con il medesimo rivestimento. Il rivestimento, non sfoderabile, può essere personalizzato con morbidi velluti e cuscini decorativi. Possibilità di rivestire lo schienale a contrasto. Il rivestimento è realizzato con piping in tinta che impreziosisce ed esalta la linea del divano.

The three-seat version has a symmetrical shape and is ideal for conversation both in public or private living spaces, it is able to create a dynamic and unusual effect. Its wooden structure features a suspension system of elastic bands, with different density expanded polyurethane stuffing. Its base is made of wood covered with the same materials. The non-removable cover can be personalised with soft velvet fabric and decorative cushions. The back can be upholstered in a contrasting colour even with decorative fabrics.

The upholstery is made with matching piping that embellishes and enhances the sofa line.

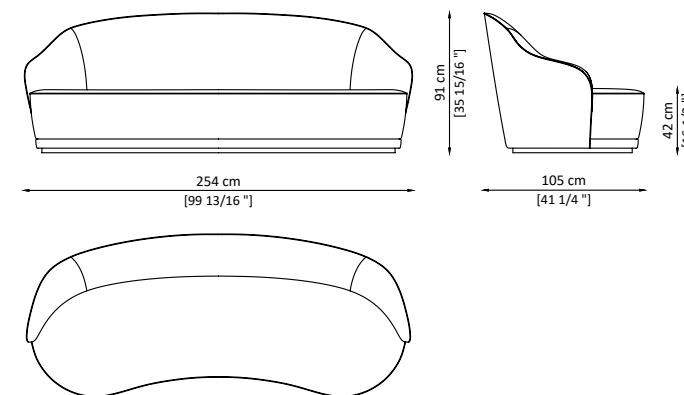

VELVET SUPERIOR | SED.LEMM.100.SUP
Fabric Velvet Superior

VELVET DELUXE | SED.LEMM.100.DEL
Fabric Velvet Deluxe

NABUK | SED.LEMM.100.NAB
Nabuk



Inspiration



ELEGANCE SOFA

DESIGN | PAOLO CASTELLI



Wood Painting
Matt Gold



Fabric Superior
Velvet Sig col. 20
Bordeaux

Elegance è un divano dal confort avvolgente e dalle forme lineari e classiche, impreziosito dal design dei piedini in metallo. Si compone di una struttura interna in acciaio e multistrato di legno con imbottitura e cuscineria in poliuretano espanso sagomato a quote differenziate. I piedini in metallo esaltano la linea e hanno una pregiata finitura oro opaco. Elegance Sofa è personalizzabile con pregiati tessuti, raffinati pelli bovine pieno fiore e nubuk. Cuscineria sedile e schienale sfoderabile.

Elegance is a sofa boasting enfolding comfort and clean, classic lines enriched by the detail of the frame and its characteristic metal feet.

The structure is made of steel and multi-layer wood while the padding and cushions are stuffed with different density expanded polyurethane. Metal feet that embellish the line have a matt gold finish. Elegance Sofa can be personalized in a wide range of elegant fabrics, fine leather and nubuck. Removable covering for seat and back cushions.

L 205

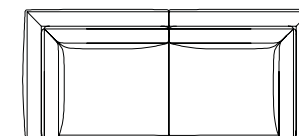
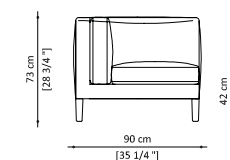
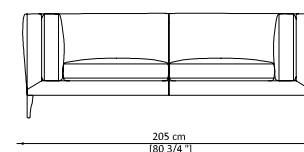

ECOLEATHER | SED.ELEG.110.ECO

Eco-Friendly Leather

FABRIC SUPERIOR | SED.ELEG.110.SUP

Fabric Superior

FABRIC DELUXE | SED.ELEG.110.DEL

Fabric Deluxe

LEATHER | SED.ELEG.110.PEL

Bovine Leather

NABUK | SED.ELEG.110.NAB

Nabuk

L 256

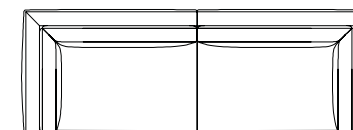
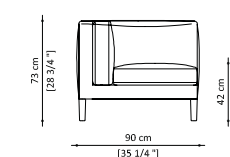
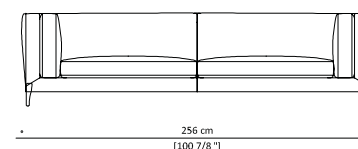

ECOLEATHER | SED.ELEG.100.ECO

Eco-Friendly Leather

FABRIC SUPERIOR | SED.ELEG.100.SUP

Fabric Superior

FABRIC DELUXE | SED.ELEG.100.DEL

Fabric Deluxe

LEATHER | SED.ELEG.100.PEL

Bovine Leather

NABUK | SED.ELEG.100.NAB

Nabuk



- ◀ **Elegante piedino
rielaborazione del classico
modello a cipolla dei mobili di
inizio secolo scorso.**

Elegant feet inspired by the
classic 'onion' model of early
1900.

Inspiration



MAMBO SOFA

DESIGN | MASSIMO IOSA GHINI



Nabuk
Col. 15 Taupe

Eleganza, cura del dettaglio e comfort sono le principali caratteristiche del divano Mambo Capitonné, realizzato con elegante manifattura, ideale da centro stanza. Presenta un telaio interno realizzato in legno multistrato e imbottito in poliuretano espanso a densità differenziate e fibra di poliestere. La preziosa manifattura del decoro realizzato a mano è ideale con rivestimento in pelle bovina pieno fiore o morbido nabuk. Non sfoderabile.

Elegance, attention to detail and comfort are the main characteristics of the Mambo Capitonné, with elegant upholstery, ideal at the center of the room. Its multi-layer wood structure is padded with different density expanded polyurethane and polyester fibre. The precious handcrafted manufacturing of the decor is ideal with the fine leather or soft nubuck finish. Unremovable covering.

SOFA

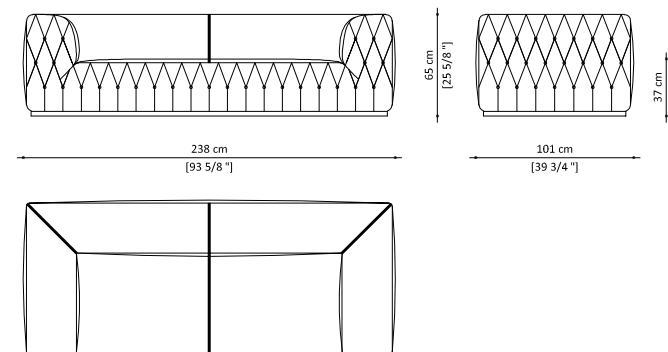

FABRIC SUPERIOR | SED. MAMB. 120. SUP

Fabric Superior

LEATHER | SED. MAMB. 120. PEL

Bovine Leather

NABUK | SED. MAMB. 120. NAB

Nabuk

POUF 50

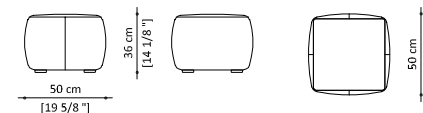

FABRIC SUPERIOR | SED. MAMB. 510. SUP

Velvet Sig Superior

LEATHER | SED. MAMB. 510. PEL

Bovine Leather

NABUK | SED. MAMB. 510. NAB

Nabuk

POUF 80

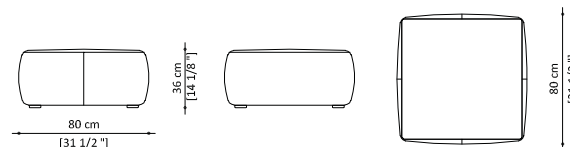

POUF 80

FABRIC SUPERIOR | SED. MAMB. 520. SUP

Velvet Sig Superior

LEATHER | SED. MAMB. 520. PEL

Bovine Leather

NABUK | SED. MAMB. 520. NAB

Nabuk



◀ Pregiata lavorazione capitonné su tutti i lati del divano.

Refined quilted handmaking.

Inspiration



SOFT RATIO SOFA

DESIGN | PAOLO CASTELLI



Available back and side options

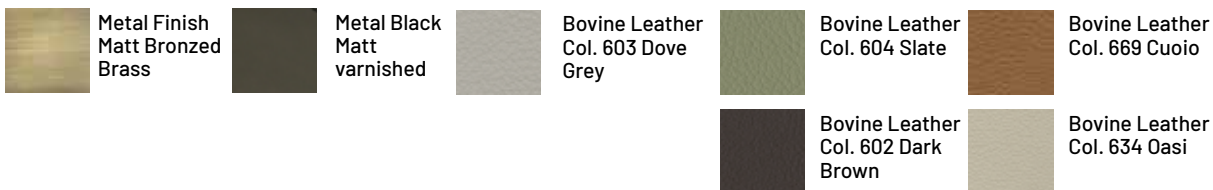

La linea Soft Ratio è un sistema di sedute componibili a 11 elementi lineari, ad angolo o a penisola che si abbinano tra loro per dare luogo a molteplici combinazioni.

La base in metallo finitura nero opaco con doppi piedini in metallo finitura bronzo ottone opaco, evidenzia la leggerezza complessiva del progetto, mentre la scocca esterna in pelle con cuciture in tinta e a contrasto nel bracciolo, e l'abbondante seduta sono il frutto di una costante ricerca nel mondo del living contemporaneo. Cuscineria sedile e schienale non sfoderabile, realizzata in poliuretano espanso sagomato a quote differenziate.

Nel modulo chaise longue con tavolino integrato il piano è realizzato in pietra Pece o rivestito in pelle.

The Soft Ratio range is a modular seating system consisting of 11 straight, corner or peninsula elements which can be mixed and matched to create multiple combinations.

The metal base matt black finish with double metal feet matt bronzed brass finish highlights the overall lightness of the design, while the leather backrest, with matching or contrasting visible stitching (even on the armrests), and the generous seat are the result of constant research into the world of contemporary living.

Seat and backrest cushion are padded in different density expanded polyurethane, covers are not removable. The chaise longue element with fixed coffee table is provided with Pietra Pece top or leather covered.

210

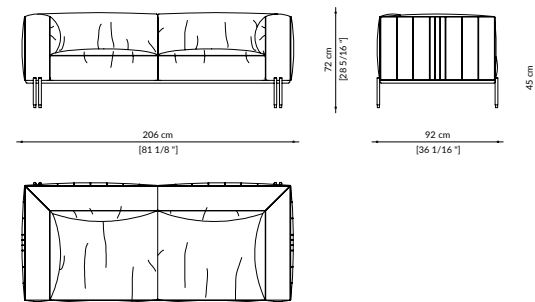

FABRIC SUPERIOR | SED.SOFT.110.SUP

Metal base matt black finish with double metal feet matt bronzed brass finish
Leather back and side covering - Upholstering Fabric Superior

FABRIC DELUXE | SED.SOFT.110.DEL

Metal base matt black finish with double metal feet matt bronzed brass finish
Leather back and side covering - Upholstering Fabric Deluxe

LEATHER | SED.SOFT.110.PEL

Metal base matt black finish with double metal feet matt bronzed brass finish
Leather back and side covering - Upholstering Bovine Leather

NABUK | SED.SOFT.110.NAB

Metal base matt black finish with double metal feet matt bronzed brass finish
Leather back and side covering - Upholstering Nabuk

250

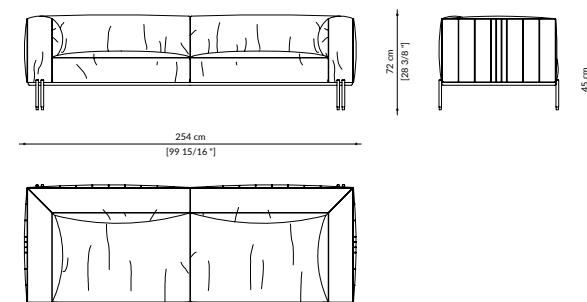

FABRIC SUPERIOR | SED.SOFT.120.SUP

Metal base matt black finish with double metal feet matt bronzed brass finish
Leather back and side covering - Upholstering Fabric Superior

FABRIC DELUXE | SED.SOFT.120.DEL

Metal base matt black finish with double metal feet matt bronzed brass finish
Leather back and side covering - Upholstering Fabric Deluxe

LEATHER | SED.SOFT.120.PEL

Metal base matt black finish with double metal feet matt bronzed brass finish
Leather back and side covering - Upholstering Bovine Leather

NABUK | SED.SOFT.120.NAB

Metal base matt black finish with double metal feet matt bronzed brass finish
Leather back and side covering - Upholstering Nabuk

SOFT RATIO COMPOSITION M



CENTRAL 170

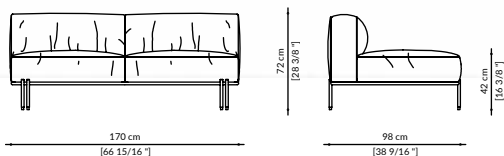

FABRIC SUPERIOR | SED.SOFT.131.SUP

Metal base matt black finish with double metal feet matt bronzed brass finish
Leather back and side covering - Upholstering Fabric Superior

FABRIC DELUXE | SED.SOFT.131.DEL

Metal base matt black finish with double metal feet matt bronzed brass finish
Leather back and side covering - Upholstering Fabric Deluxe

LEATHER | SED.SOFT.131.PEL

Metal base matt black finish with double metal feet matt bronzed brass finish
Leather back and side covering - Upholstering Bovine Leather

NABUK | SED.SOFT.131.NAB

Metal base matt black finish with double metal feet matt bronzed brass finish
Leather back and side covering - Upholstering Nabuk

CENTRAL 170 LEFT BACK

also available right model

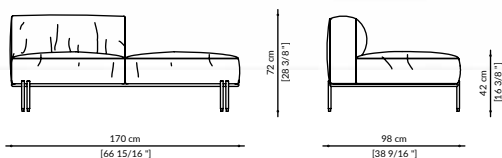

FABRIC SUPERIOR | SED.SOFT.132.SUP

Metal base matt black finish with double metal feet matt bronzed brass finish
Leather back and side covering - Upholstering Fabric Superior

FABRIC DELUXE | SED.SOFT.132.DEL

Metal base matt black finish with double metal feet matt bronzed brass finish
Leather back and side covering - Upholstering Fabric Deluxe

LEATHER | SED.SOFT.132.PEL

Metal base matt black finish with double metal feet matt bronzed brass finish
Leather back and side covering - Upholstering Bovine Leather

NABUK | SED.SOFT.132.NAB

Metal base matt black finish with double metal feet matt bronzed brass finish
Leather back and side covering - Upholstering Nabuk

TERMINAL 190 LEFT

also available right model

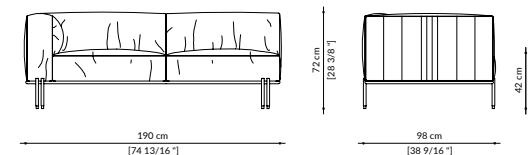

FABRIC SUPERIOR | SED.SOFT.133.SUP

Metal base matt black finish with double metal feet matt bronzed brass finish
Leather back and side covering - Upholstering Fabric Superior

FABRIC DELUXE | SED.SOFT.133.DEL

Metal base matt black finish with double metal feet matt bronzed brass finish
Leather back and side covering - Upholstering Fabric Deluxe

LEATHER | SED.SOFT.133.PEL

Metal base matt black finish with double metal feet matt bronzed brass finish
Leather back and side covering - Upholstering Bovine Leather

NABUK | SED.SOFT.133.NAB

Metal base matt black finish with double metal feet matt bronzed brass finish
Leather back and side covering - Upholstering Nabuk

CHAISE LONGUE 190 LEFT

also available right model

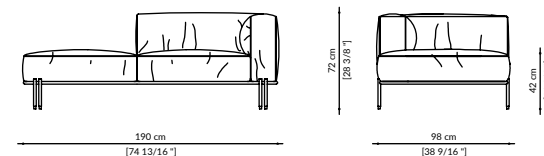

FABRIC SUPERIOR | SED.SOFT.334.SUP

Metal base matt black finish with double metal feet matt bronzed brass finish
Leather back and side covering - Upholstering Fabric Superior

FABRIC DELUXE | SED.SOFT.334.DEL

Metal base matt black finish with double metal feet matt bronzed brass finish
Leather back and side covering - Upholstering Fabric Deluxe

LEATHER | SED.SOFT.334.PEL

Metal base matt black finish with double metal feet matt bronzed brass finish
Leather back and side covering - Upholstering Bovine Leather

NABUK | SED.SOFT.334.NAB

Metal base matt black finish with double metal feet matt bronzed brass finish
Leather back and side covering - Upholstering Nabuk

OPTIONAL BACK SUPPORT - 60 x 60 cm (round element Ø12 x 45cm)

FABRIC SUPERIOR | COM.SOFT.CUS.SUP

FABRIC DELUXE | COM.SOFT.CUS.DEL

LEATHER | COM.SOFT.CUS.PEL

NABUK | COM.SOFT.CUS.NAB

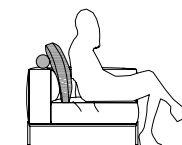

SOFT RATIO COMPOSITION L

CENTRAL 210

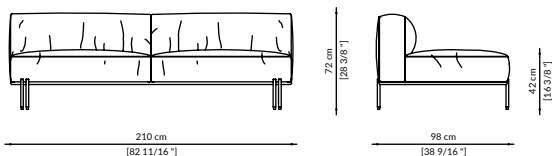

FABRIC SUPERIOR | SED.SOFT.141.SUP

Metal base matt black finish with double metal feet matt bronzed brass finish
Leather back and side covering - Upholstering Fabric Superior

FABRIC DELUXE | SED.SOFT.141.DEL

Metal base matt black finish with double metal feet matt bronzed brass finish
Leather back and side covering - Upholstering Fabric Deluxe

LEATHER | SED.SOFT.141.PEL

Metal base matt black finish with double metal feet matt bronzed brass finish
Leather back and side covering - Upholstering Bovine Leather

NABUK | SED.SOFT.141.NAB

Metal base matt black finish with double metal feet matt bronzed brass finish
Leather back and side covering - Upholstering Nabuk

CENTRAL 210 LEFT BACK also available right model

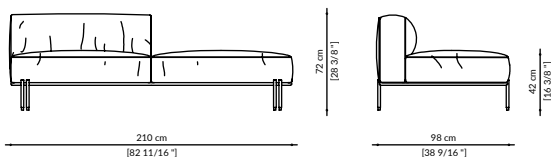

FABRIC SUPERIOR | SED.SOFT.142.SUP

Metal base matt black finish with double metal feet matt bronzed brass finish
Leather back and side covering - Upholstering Fabric Superior

FABRIC DELUXE | SED.SOFT.142.DEL

Metal base matt black finish with double metal feet matt bronzed brass finish
Leather back and side covering - Upholstering Fabric Deluxe

LEATHER | SED.SOFT.142.PEL

Metal base matt black finish with double metal feet matt bronzed brass finish
Leather back and side covering - Upholstering Bovine Leather

NABUK | SED.SOFT.142.NAB

Metal base matt black finish with double metal feet matt bronzed brass finish
Leather back and side covering - Upholstering Nabuk

TERMINAL 230 LEFT also available right model

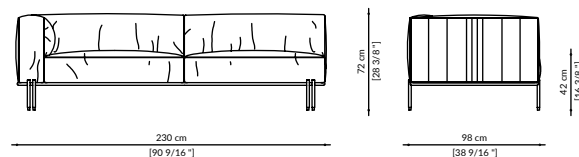

FABRIC SUPERIOR | SED.SOFT.143.SUP

Metal base matt black finish with double metal feet matt bronzed brass finish
Leather back and side covering - Upholstering Fabric Superior

FABRIC DELUXE | SED.SOFT.143.DEL

Metal base matt black finish with double metal feet matt bronzed brass finish
Leather back and side covering - Upholstering Fabric Deluxe

LEATHER | SED.SOFT.143.PEL

Metal base matt black finish with double metal feet matt bronzed brass finish
Leather back and side covering - Upholstering Bovine Leather

NABUK | SED.SOFT.143.NAB

Metal base matt black finish with double metal feet matt bronzed brass finish
Leather back and side covering - Upholstering Nabuk

CHAISE LONGUE 230 LEFT

also available right model

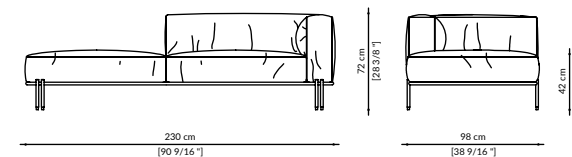

FABRIC SUPERIOR | SED.SOFT.344.SUP

Metal base matt black finish with double metal feet matt bronzed brass finish
Leather back and side covering - Upholstering Fabric Superior

FABRIC DELUXE | SED.SOFT.344.DEL

Metal base matt black finish with double metal feet matt bronzed brass finish
Leather back and side covering - Upholstering Fabric Deluxe

LEATHER | SED.SOFT.344.PEL

Metal base matt black finish with double metal feet matt bronzed brass finish
Leather back and side covering - Upholstering Bovine Leather

NABUK | SED.SOFT.344.NAB

Metal base matt black finish with double metal feet matt bronzed brass finish
Leather back and side covering - Upholstering Nabuk

CHAISE LONGUE 230 LEFT WITH TABLE (for composition M and L)

also available right model

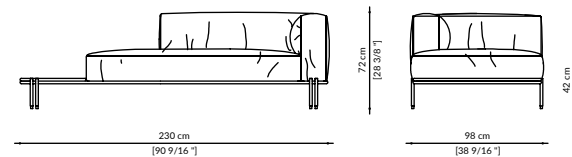

FABRIC SUPERIOR | SED.SOFT.345.SUP

Metal base matt black finish with double metal feet matt bronzed brass finish
Leather back and side covering - Upholstering Fabric Superior

FABRIC DELUXE | SED.SOFT.345.DEL

Metal base matt black finish with double metal feet matt bronzed brass finish
Leather back and side covering - Upholstering Fabric Deluxe

LEATHER | SED.SOFT.345.PEL

Metal base matt black finish with double metal feet matt bronzed brass finish
Leather back and side covering - Upholstering Bovine Leather

NABUK | SED.SOFT.345.NAB

Metal base matt black finish with double metal feet matt bronzed brass finish
Leather back and side covering - Upholstering Nabuk



Inspiration



DROMO CLUB SOFA

DESIGN | VITTORIO PARADISO



Nabuck
Col. 08 Olive



Wood
Black Ashwood

Dromo Club è una declinazione della linea Dromo, nata come omaggio al grande maestro Carlo Scarpa e alla sua città. Lo sviluppo del basamento fino a terra rafforza l'invito alla seduta e al relax, trasformandone la silhouette elegante in una proposta dal forte impatto geometrico, capace di interpretare il ruolo di protagonista in ogni ambiente. Cuscineria sedile e schienale sfoderabile, imbottitura in poliuretano espanso sagomato a quote differenziate e piuma d'oca. Il rivestimento è in pelle, nabuk o tessuto con piping in tessuto col. marrone (Ref. Fabric Sateen D6037815 Brown) o in tinta.

Dromo Club is a development of the Dromo line, conceived as a tribute to the great artist Carlo Scarpa and his home town.

The extension of the base to the floor emphasises the invitation to sit down and relax, transforming the elegant silhouette into a proposal with a strong geometric impact, capable of playing the leading role in any setting. Removable seat and backrest cushion covers, padding in different density expanded polyurethane added with feather padding.

Upholstered in leather, nubuck or fabric with piping in brown fabric (Ref. Fabric Sateen D6037815 Brown) or in the same colour as the upholstery.

3 SEATS

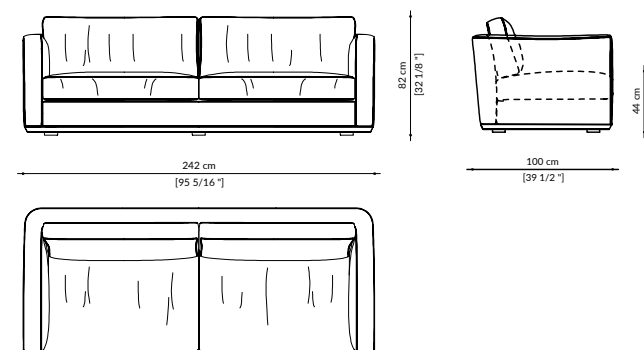

ECOLEATHER | SED.DROM.140.ECO

Wooden base back ashwood - Ecoleather

FABRIC SUPERIOR | SED.DROM.140.SUP

Wooden base back ashwood - Fabric Superior

FABRIC DELUXE | SED.DROM.140.DEL

Wooden base back ashwood - Fabric Deluxe

LEATHER | SED.DROM.140.PEL

Wooden base back ashwood - Bovine Leather

NABUK | SED.DROM.140.NAB

Wooden base back ashwood - Nabuk

4 SEATS

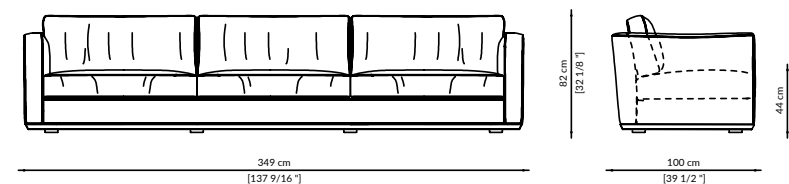

ECOLEATHER | SED.DROM.141.ECO

Wooden base back ashwood - Ecoleather

FABRIC SUPERIOR | SED.DROM.141.SUP

Wooden base back ashwood - Fabric Superior

FABRIC DELUXE | SED.DROM.141.DEL

Wooden base back ashwood - Fabric Deluxe

LEATHER | SED.DROM.141.PEL

Wooden base back ashwood - Bovine Leather

NABUK | SED.DROM.141.NAB

Wooden base back ashwood - Nabuk

DROMO CLUB COMPOSITION

CENTRAL 215

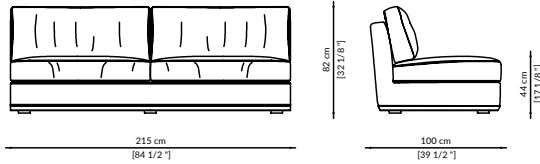

ECOLEATHER | SED.DROM.151.ECO
Wooden base back ashwood - Ecoleather

FABRIC SUPERIOR | SED.DROM.151.SUP
Wooden base back ashwood - Fabric Superior

FABRIC DELUXE | SED.DROM.151.DEL
Wooden base back ashwood - Fabric Deluxe

LEATHER | SED.DROM.151.PEL
Wooden base back ashwood - Bovine Leather

NABUK | SED.DROM.151.NAB
Wooden base back ashwood - Nabuk

CENTRAL 215 LEFT BACK also available right model

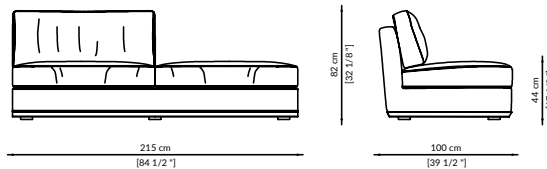

ECOLEATHER | SED.DROM.152.ECO
Wooden base back ashwood - Ecoleather

FABRIC SUPERIOR | SED.DROM.152.SUP
Wooden base back ashwood - Fabric Superior

FABRIC DELUXE | SED.DROM.152.DEL
Wooden base back ashwood - Fabric Deluxe

LEATHER | SED.DROM.152.PEL
Wooden base back ashwood - Bovine Leather

NABUK | SED.DROM.152.NAB
Wooden base back ashwood - Nabuk

TERMINAL 229 LEFT also available right model

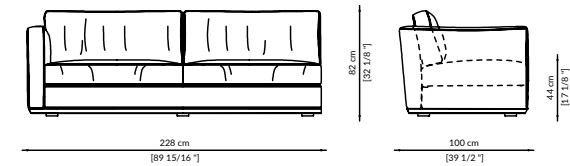

ECOLEATHER | SED.DROM.153.ECO
Wooden base back ashwood - Ecoleather

FABRIC SUPERIOR | SED.DROM.153.SUP
Wooden base back ashwood - Fabric Superior

FABRIC DELUXE | SED.DROM.153.DEL
Wooden base back ashwood - Fabric Deluxe

LEATHER | SED.DROM.153.PEL
Wooden base back ashwood - Bovine Leather

NABUK | SED.DROM.153.NAB
Wooden base back ashwood - Nabuk

CHAISE LONGUE 245 LEFT

also available right model

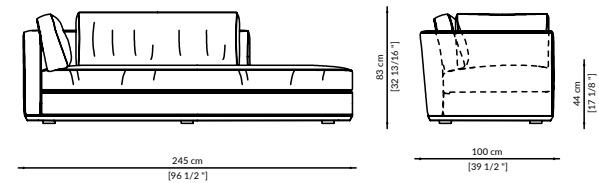

ECOLEATHER | SED.DROM.350.ECO
Wooden base back ashwood - Ecoleather

FABRIC SUPERIOR | SED.DROM.350.SUP
Wooden base back ashwood - Fabric Superior

FABRIC DELUXE | SED.DROM.350.DEL
Wooden base back ashwood - Fabric Deluxe

LEATHER | SED.DROM.350.PEL
Wooden base back ashwood - Bovine Leather

NABUK | SED.DROM.350.NAB
Wooden base back ashwood - Nabuk





Inspiration



DROMO SOFA

DESIGN | PAOLO CASTELLI & VITTORIO PARADISO



Wood
Dark Oak



Matt
Brass



Fabric Superior
Velvet Mana
Col. 0714 Dove

Dromo Sofa nasce come omaggio al grande maestro Carlo Scarpa e alla sua città. Si presenta come una piattaforma sospesa, dove il volume importante della cuscineria è reso più leggero dalla struttura in rovere massello tinto scuro, impreziosita dagli elementi esagonali in ottone naturale satinato.

Il rivestimento è in pelle, nabuk o tessuto con piping in tessuto col. marrone (Ref. Fabric Sateen D6037815 Brown) o in tinta. È disponibile nella versione 3 posti, poltrona e angolare.

Cuscineria sedile e schienale sfoderabile, imbottitura in poliuretano espanso sagomato a quote differenziate e piuma d'oca.

Dromo Sofa came into being as a tribute to the great master Carlo Scarpa and his town. It appears like a suspended platform where the significant volume of the cushions is rendered lighter by the structure in solid oak dark painted. It is enriched by precious details such as the hexagonal elements in natural satin brass on the legs of the structure.

The upholstery is in leather, nubuck or fabric with piping in fabric col. brown (Ref. Fabric Sateen D6037815 Brown) or matching. Available in three-seat and corner versions.

The armchair is also available. Removable covering for seat and back cushions, padding in different density expanded polyurethane added with feather padding.

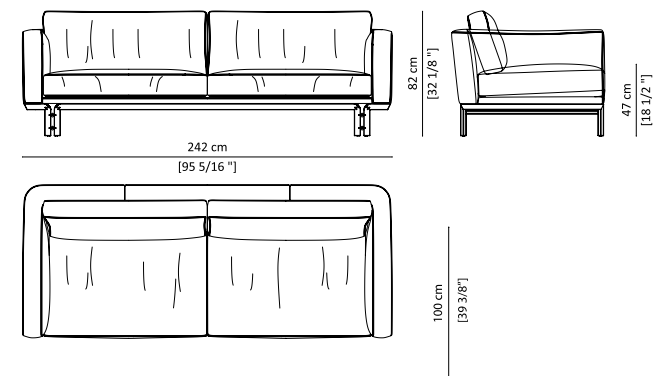

FABRIC SUPERIOR | SED.DROM.120.SUP

Base in Oak finish - Piping col. 16 brown
Fabric Superior

FABRIC DELUXE | SED.DROM.120.DEL

Base in Oak finish - Piping col. 16 brown
Fabric Deluxe

LEATHER | SED.DROM.120.PEL

Base in Oak finish - Piping col. 16 brown
Bovine Leather

NABUK | SED.DROM.120.NAB

Base in Oak finish - Piping col. 16 brown
Nabuk



▲
Elementi esagonali in ottone
naturale satinato.

Hexagonal details in matte
natural brass.

Inspiration



DROMO ANGULAR

DESIGN | PAOLO CASTELLI & VITTORIO PARADISO



Wood
Dark Oak



Fabric Superior
Velvet Mana
Col. 0714 Dove



Matt
Brass

Dromo Sofa nasce come omaggio al grande maestro Carlo Scarpa e alla sua città. Si presenta come una piattaforma sospesa, dove il volume importante della cuscineria è reso più leggero dalla struttura in rovere massello tinto scuro, impreziosita dagli elementi esagonali in ottone naturale satinato.

Il rivestimento è in pelle, nabuk o tessuto con piping in tessuto col. marrone (Ref. Fabric Sateen D6037815 Brown) o in tinta. È disponibile nella versione 3 posti, poltrona e angolare.

Cuscineria sedile e schienale sfoderabile, imbottitura in poliuretano espanso sagomato a quote differenziate e piuma d'oca.

Dromo Sofa came into being as a tribute to the great master Carlo Scarpa and his town. It appears like a suspended platform where the significant volume of the cushions is rendered lighter by the structure in solid oak dark painted. It is enriched by precious details such as the hexagonal elements in natural satin brass on the legs of the structure.

The upholstery is in leather, nubuck or fabric with piping in fabric col. brown (Ref. Fabric Sateen D6037815 Brown) or matching. Available in three-seat and corner versions.

The armchair is also available. Removable covering for seat and back cushions, padding in different density expanded polyurethane added with feather padding.

DROMO ANGULAR SX - also available dx model

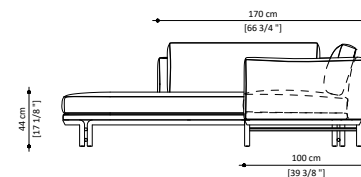
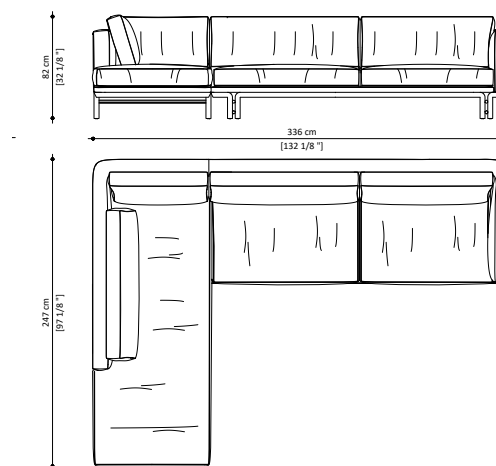

DX / SX

FABRIC SUPERIOR | SED.DROM.110/130.SUP

Base in Oak finish - Piping col. 16 brown
Fabric Superior

FABRIC DELUXE | SED.DROM.110/130.DEL

Base in Oak finish - Piping col. 16 brown
Fabric Deluxe

LEATHER | SED.DROM.110./130.PEL

Base in Oak finish - Piping col. 16 brown
Bovine Leather

NABUK | SED.DROM.110/130.NAB

Base in Oak finish - Piping col. 16 brown
Nabuk



Inspiration

C

FLUON SOFA

DESIGN | MASSIMO IOSA GHINI



Nabuck
Col. 02 Dark Brown

Il telaio interno è realizzato in massello d'abete multistrato di pino cileno, con inserto interno composto da cinghie elastiche e imbottitura con schiuma poliuretanic a espansa indeformabile, di densità a quote differenziate, e ricoperto da una soffice trapunta in cotone 100% imbottita con piuma d'oca per aumentarne il confort. Il design offre un profilo ben disegnato con il taglio vivo del nabuk, mentre la versione in tessuto, non sfoderabile, è impreziosita da una doppia orlatura. La serie Fluon si articola in divano a 3 posti, composizione ad angolo, poltrona e pouf. Non sfoderabile. Cuscino lombare incluso

Its structure is multi-layer solid Chilean pine wood, with an internal system of elastic bands padded with polyurethane crushproof foam entirely covered by a soft quilt of 100% cotton, added with goose down for additional comfort. The nabuk version boasts a well-defined profile thanks to its cut, while the fabric version, with non-removable cover, is enriched by a double seam. The fluon range includes 3 sofas, corner sofa, armchair and pouf. Unremovable covering. Lumbar cushion included.

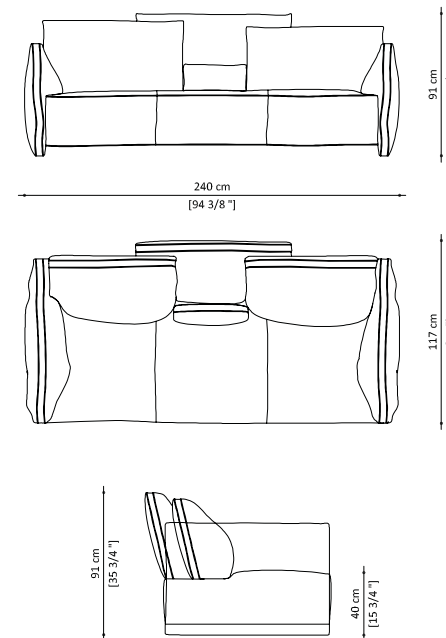

VELVET SUPERIOR | SED.FLUO.120.SUP
Velvet Superior

HAMMERED VELVET DELUXE | SED.FLUO.120.DEL
Hammered Velvet

NABUK | SED.FLUO.120.NAB
Nabuk

Inspiration



FLUON ANGULAR

DESIGN | MASSIMO IOSA GHINI



Nabuck
Col. 08 Olive

Il telaio interno è realizzato in massello d'abette multistrato di pino cileno, con inserto interno composto da cinghie elastiche e imbottitura con schiuma poliuretana espansa indeformabile, di densità a quote differenziate, e ricoperto da una soffice trapunta in cotone 100% imbottita con piuma d'oca per aumentarne il confort. Il design offre un profilo ben disegnato con il taglio a vista del nabuk, mentre la versione in tessuto è impreziosita da una doppia orlatura. La serie Fluon si articola in divano a 3 posti, composizione ad angolo, poltrona e pouf. Non sfoderabile. Cuscino lombare incluso.

Its structure is multi-layer solid Chilean pine wood, with an internal system of elastic bands padded with expanded polyurethane crushproof foam entirely covered by a soft quilt of 100% cotton, added with goose down for additional comfort. The nabuk version boasts a well-defined profile thanks to its cut, while the fabric version, with non-removable cover, is enriched by a double seam. The fluon range includes 3 sofas, corner sofa, armchair and pouf. Unremovable covering. Lumbar cushion included.

FLUON DX - also available sx model

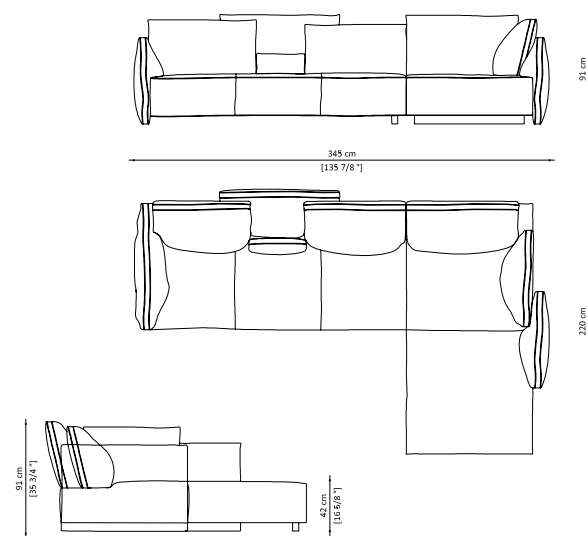

DX / SX
VELVET SUPERIOR | SED.FLUO.110/111.SUP
Velvet Superior

HAMMERED VELVET DELUXE | SED.FLUO.110/111.DEL
Fabric Hammered Velvet

NABUK | SED.FLUO.110/111.NAB
Nabuk

DURBAN SOFA

DESIGN | SAMUELE MAZZA



Wood
Elm Grey



Fabric Superior
Blended linen
col. Gog Ivory

Un grande divano a forma di arco, realizzato con struttura in legno di olmo cenere che "incastona" la soffice seduta, rivestita in pregiati tessuti o pelli. L'imbottitura della seduta è realizzata in poluretano espanso sagomato a quote differenziate e divisa in 4 porzioni, quella dello schienale è predisposta sempre con 4 cuscini fissi cui si aggiungono 7 mobili. Il divano ha piping in tessuto col. marrone in tinta con la base. La serie comprende anche la poltrona angolare, fornita con due cuscini mobili, ed il pouf. Cuscinatura schienale sfoderabile.

Wrapping and comfortable shapes. A large arch-shaped sofa, made with an elm ash wood structure that "embeds" the soft seat, upholstered in precious fabrics or leathers. The padding of the seat is made of different density expanded polyurethane and divided in 4 portions, while that of the back is portioned in 4 fixed cushions to which are added 7movable cushions. The sofa has piping in fabric col. brown to match the base. The series also includes the corner armchair, supplied with two movable cushions, and the pouf. Back cushion with removable covering.

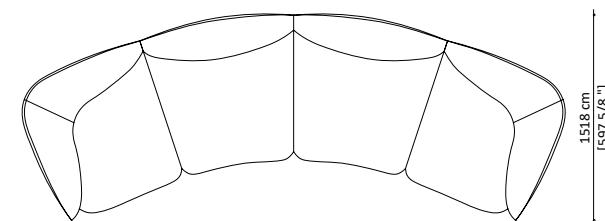
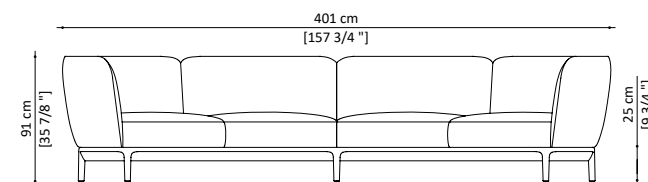

FABRIC SUPERIOR | SED.DURB.110.SUP

Base in ash elm wood 0 gloss - Piping col. 16 brown
Fabric Superior

FABRIC DELUXE | SED.DURB.110.DEL

Base in ash elm wood 0 gloss - Piping col. 16 brown
Fabric Deluxe

LEATHER | SED.DURB.110.PEL

Base in ash elm wood 0 gloss - Piping col. 16 brown
Bovine Leather

NABUK | SED.DURB.110.NAB

Base in ash elm wood 0 gloss - Piping col. 16 brown
Nabuk



Inspiration



VICTOR SOFA

DESIGN | PAOLO CASTELLI



Metal Finish
Matt Gold



Leather
Col. Dark Brown



Fabric Deluxe
Sun Col. 03 Sand

Geometrie maschili, carattere deciso che ne enfatizza la personalità: Victor Sofa ha una struttura solida in metallo, arricchita da finitura oro opaco e preziosi dettagli in cuoio testa di moro abbinati a una cuscineria con piping in tinta resa morbida ed accogliente grazie ad un'imbottitura realizzata in soffice piuma d'oca.

Sui fianchi e sul retro, troviamo un appoggio rivestito in cuoio testa di moro che consente di depositare libri e piccoli oggetti. Il divano è disponibile con rivestimento in pregiate pelli ed eleganti tessuti. Cuscineria sedile e schienale sfoderabile.

Masculine geometries, strong character emphasizing its personality. Victor Sofa has a solid structure made of metal enriched by a matt gold finish and precious details in dark brown emery leather, combined with soft and cozy three-seat cushions with piping in the same colour, with a feather padding.

On the sides and back it features a plane upholstered in dark brown emery leather so that books and other little items can be put on it. The sofa is available in fine leather and precious fabric. Removable covering for seat and back cushions.

2 SEATS

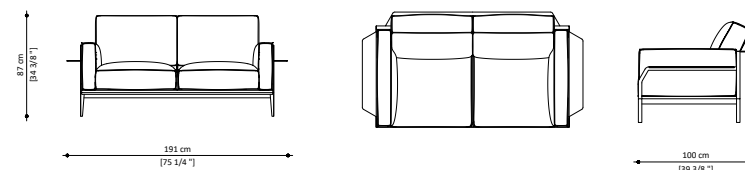

FABRIC SUPERIOR | SED.VICT.110.SUP

Matt gold metal base - Dark brown leather details
Fabric Superior

FABRIC DELUXE | SED.VICT.110.DEL

Matt gold metal base - Dark brown leather details
Fabric Deluxe

LEATHER | SED.VICT.110.PEL

Matt gold metal base - Dark brown leather details
Bovine Leather

NABUK | SED.VICT.110.NAB

Matt gold metal base - Dark brown leather details
Nabuk

3 SEATS

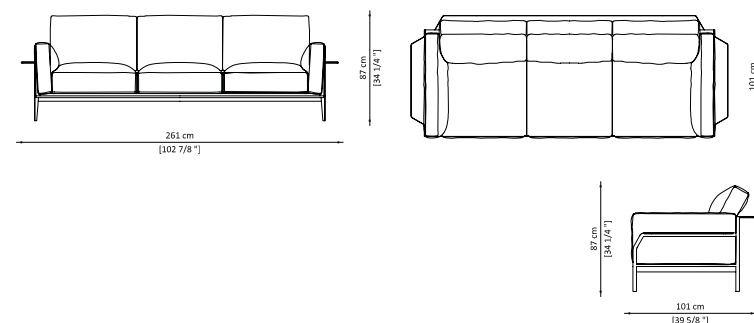

FABRIC SUPERIOR | SED.VICT.100.SUP

Matt gold metal base - Dark brown leather details
Fabric Superior

FABRIC DELUXE | SED.VICT.100.DEL

Matt gold metal base - Dark brown leather details
Fabric Deluxe

LEATHER | SED.VICT.100.PEL

Matt gold metal base - Dark brown leather details
Bovine Leather

NABUK | SED.VICT.100.NAB

Matt gold metal base - Dark brown leather details
Nabuk



C



◀ **Comodo ed elegante ripiano
d'appoggio sullo schienale e
sui fianchi.**

Elegant and comfortable shelf
along the back and on the
sides.

Inspiration



SEAN SOFA

DESIGN | PAOLO CASTELLI



Nabuck
Col. 08 Olive



Bronze Mirrored
Glass Matt



Metal Finish
Matt Gold

Sean divano angolare ha la chiarezza strutturale e le proporzioni limpide di un'architettura. Il suo equilibrio nasce dalla riduzione di qualsiasi elemento superfluo e dalla costruzione proporzionata delle sue componenti. La struttura in legno è rivestita con lamiera metallica finitura oro opaco, innovativo l'inserto in vetro specchiato satinato color bronzo che conferisce leggerezza al divano. Imbottitura in poluretano espanso sagomato a quote differenziate. Rivestimento, non sfoderabile, disponibile in pregiati pelli e tessuti.

A corner sofa that has the structural clarity and clear proportions of architecture. Its balance is the result of the reduction of any superfluous elements and from the proportionate construction of its components. The wooden structure is covered with a metallic gold matt finish, and the bronze mirrored glass matt insert that gives the sofa its lightness is an innovative touch. Padding is made in different density expanded polyurethane. The non removable covers are available in fine leathers and fabrics.

SEAN DX - also available sx model

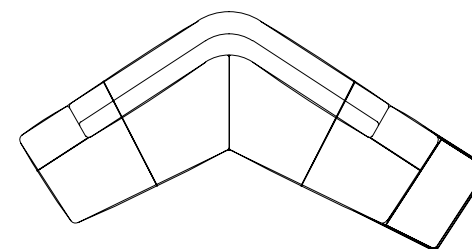
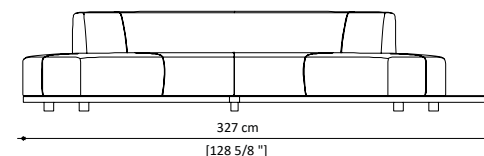
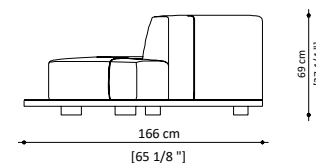

SEAN DX / SX
FABRIC SUPERIOR | SED.SEAN.110/100.SUP
Fabric Superior

FABRIC DELUXE | SED.SEAN.110/100.DEL
Fabric Deluxe

LEATHER | SED.SEAN.110/100.PEL
Bovine Leather

NABUK | SED.SEAN.110/100.NAB
Nabuk



Inspiration

C

PETALO SOFA

DESIGN | GIAMPIERO PELA



Metal Finish
Matt Gold



Fabric
Velvet Superior Mana
Col. 2204 Teal

Petalo Sofa, con le sue forme avvolgenti e l'alto schienale è un divano insolito dalla forte identità. Il divano ha una struttura in legno di faggio curvato e un sistema di molleggio con cinghie elastiche incrociate. Imbottitura in poluretano espanso sagomato a quote differenziate. Il rivestimento, non sfoderabile, può essere realizzato in pelle bovina pieno fiore o in eleganti velluti. Infine, lo zoccolo è rivestito in laminato metallico finitura oro satinato.

Its enfolding shape and high backrest give it a unique and distinctive look. Its beech structure features a suspension system of crossing elastic bands. Padding is made in different density expanded polyurethane. The non-removable cover can be personalized with soft velvet fabric or fine leather. Additionally, the base is covered in metal laminate with a gold matt finish.

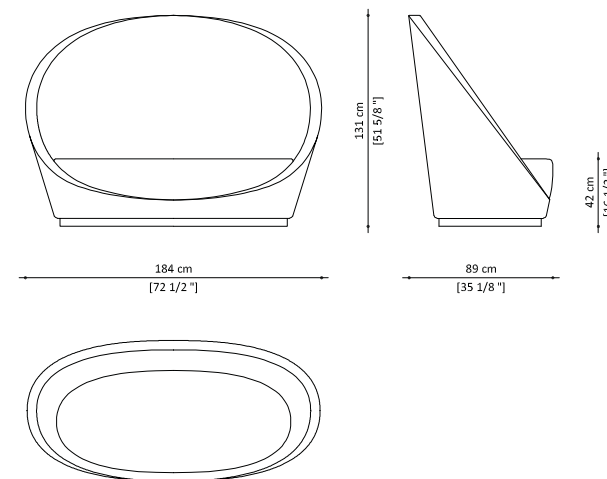

ECOLEATHER | SED.PETA.100.ECO
Eco-Friendly Leather

FABRIC SUPERIOR | SED.PETA.100.SUP
Fabric Superior

LEATHER | SED.PETA.100.PEL
Bovine Leather

NABUK | SED.PETA.100.NAB
Nabuk

(Decorative cushions not included)



C

Inspiration



ORUS SOFA

DESIGN | PAOLO CASTELLI



Metal Finish
Matt Gold



Fabric Superior
Velvet Sig Col. 20
Bordeaux

Orus Sofa è un divanetto compatto ed elegante con uno schienale avvolgente, un regale mantello che vi accoglie tra i suoi drappi e ascolta le più frizzanti conversazioni.

Divanetto a due sedute dal richiamo "belle époque", consta di una struttura interna in multistrato di legno curvato con imbottitura in poliuretano a densità variabile. Ha un rivestimento, non sfoderabile, personalizzabile con pregiati tessuti, raffinate pelli bovine pieno fiore e nubuk. Il divano poggia su di una struttura in metallo con gambe disposte ad incrocio, arricchite con preziosa finitura oro opaco.

Orus Sofa is a smart and compact love seat featuring an enchanting seatback, a noble cover embracing you among its drapes and capturing the most sparkling speeches. Two-seat sofa evoking the charme of belle époque, it consists in a curved multilayer wooden internal structure, the padding is made from different density expanded polyurethane. The non removable cover can be personalized with graceful fabrics, refined bovine grain leather and nubuck. Its base is made of an all-metal structure with criss-crossed legs enriched by a precious mat gold finish.

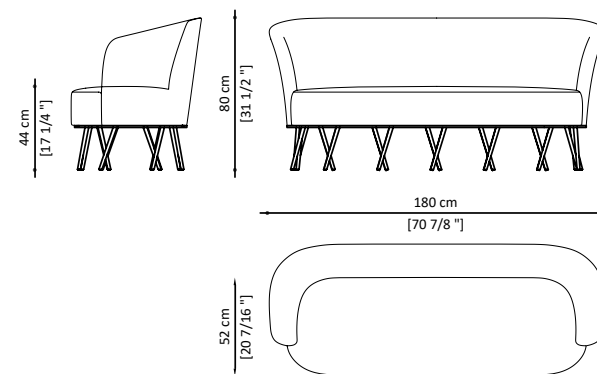

FABRIC SUPERIOR | SED.ORUS.100.SUP

Matt gold metal base
Fabric Superior

FABRIC DELUXE | SED.ORUS.100.DEL

Matt gold metal base
Fabric Deluxe

LEATHER | SED.ORUS.100.PEL

Matt gold metal base
Bovine Leather

NABUK | SED.ORUS.100.NAB

Matt gold metal base
Nabuk



◀ **Ispirazione "Belle Epoque" per il divertente gioco di incroci delle gambe.**

The criss-cross twist of the legs comes from 'Belle époque' inspiration.

Inspiration



ORUS DORMEUSE

DESIGN | PAOLO CASTELLI



Metal Finish
Matt Gold



Fabric Superior
Velvet Sig Col. 07
Graphite

Orus dormeuse ha forme seducenti ed avvolgenti dal richiamo "belle époque". Perfetta per ambienti da conversazione o privati, consta di una struttura interna in multistrato di legno curvato con imbottitura in poliuretano a densità variabile. Ha un rivestimento, non sfoderabile, personalizzabile con pregiati tessuti, raffinate pelli bovine pieno fiore e nubuck. La dormeuse poggia su di una struttura in metallo con gambe disposte ad incrocio, arricchite con preziosa finitura oro opaco.

Orus dormeuse owns enchanting and embracing shapes recalling the "belle-époque" charme. Ideal for conversation or private living spaces, it consists in a curved multilayer wooden internal structure, the padding is made from different density expanded polyurethane. The non removable cover can be personalized with graceful fabrics, refined bovine grain leather and nubuck. The dormeuse lies on an all-metal structure with criss-crossed legs enriched by a precious mat gold finish.

ORUS DORMEUSE DX - also available sx model

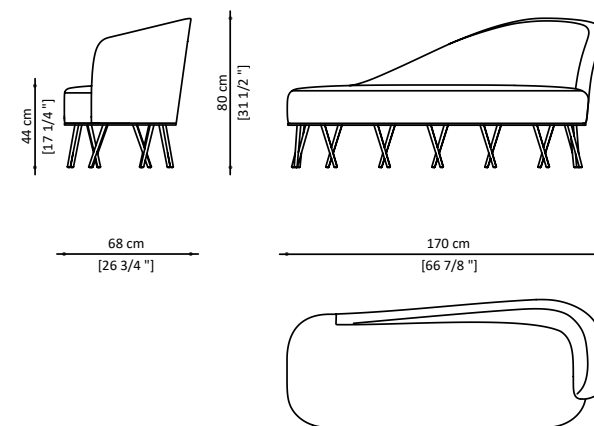

DX / SX
FABRIC SUPERIOR | SED.ORUS.110/120.SUP
Matt gold metal base
Fabric Superior

FABRIC DELUXE | SED.ORUS.110/120.DEL
Matt gold metal base
Fabric Deluxe

LEATHER | SED.ORUS.110/120.PEL
Matt gold metal base
Bovine Leather

NABUK | SED.ORUS.110/120.NAB
Matt gold metal base
Nabuk



Inspiration

C

VICTOR CHAISE LONGUE

DESIGN | PAOLO CASTELLI



Metal Finish
Matt Gold



Leather
Col. Dark Brown



Fabric Deluxe
Sun Col. 03 Sand

Victor chaise longue ha una struttura solida in metallo, arricchita da finitura oro opaco e preziosi dettagli in cuoio testa di moro abbinati a una cuscineria con piping in tinta resa morbida ed accogliente grazie ad un'imbottitura realizzata in soffice piuma d'oca. Sul fianco e sul retro, troviamo un appoggio rivestito in cuoio testa di moro che consente di depositare libri e piccoli oggetti. La chaise longue è disponibile con rivestimento in pregiate pelli ed eleganti tessuti. Cuscini seduta e schienale sfoderabili.

Victor chaise longue has a solid structure made of metal enriched by a mat gold finish and precious details in dark brown emery leather, combined with soft and cosy three-seat cushions with matching piping. On the sides and back it features a plane upholstered in dark brown emery leather so that books and other little items can be put on it. The chaise longue is available in fine leather and precious fabric upholstery. Removable covering for back and seat cushions.

DX - also available sx model

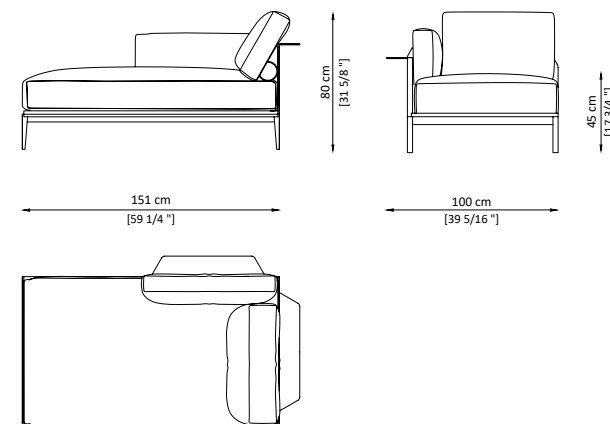

DX / SX
FABRIC SUPERIOR | SED.VICT.300/310.SUP
Matt gold metal base - Dark brown leather details
Fabric Superior

FABRIC DELUXE | SED.VICT.300/310.DEL
Matt gold metal base - Dark brown leather details
Fabric Deluxe

LEATHER | SED.VICT.300/310.PEL
Matt gold metal base - Dark brown leather details
Bovine Leather

NABUK | SED.VICT.300/310.NAB
Matt gold metal base - Dark brown leather details
Nabuk



Inspiration

C

ELEGANCE CHAISE LONGUE

DESIGN | PAOLO CASTELLI



Wood Painted
Matt Gold



Fabric
Velvet Superior Mana
Col. Green Grey

Elegance Chaise Lounge è un imbottito dalle forme lineari, ideali da bordo del letto ma valide anche per ingressi e camere guardaroba. Ha una struttura interna in multistrato di legno con imbottitura in poliuretano a densità variabile.

E' decorato con cuscini cilindrici e i piedini sono in metallo con finitura oro opaco. E' personalizzabile con pregiati tessuti, raffinati pelli bovine pieno fiore e nabuk.

Elegance Chaise Lounge is a padded chair with an elegant design. Ideal in entrances, living spaces, wardrobe areas and bedrooms.

The structure is made of multi-layer wood with padding made in different density expanded polyurethane. It is decorated with a cylindrical cushion and the metal feet have a matt gold finish. The product can be personalized in a wide range of elegant fabrics, fine leather and nubuck.

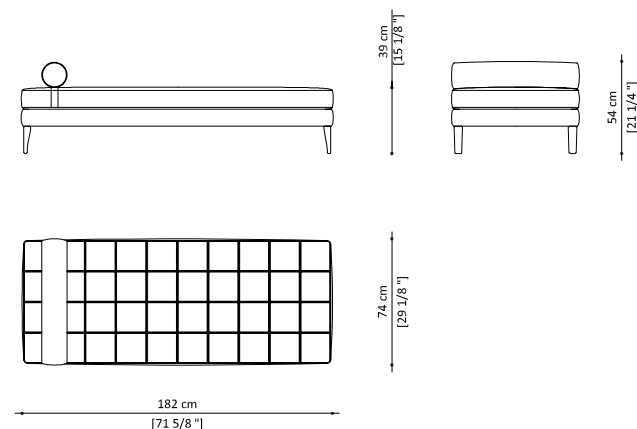

ECOLEATHER | SED.ELEG.300.ECO
Eco-Friendly Leather

VELVET SUPERIOR | SED.ELEG.300.SUP
Fabric Superior

VELVET DELUXE | SED.ELEG.300.DEL
Fabric Deluxe

LEATHER | SED.ELEG.300.PEL
Bovine Leather

NABUK | SED.ELEG.300.NAB
Nabuk

(1 round cushion included)



◀ **Elegante piedino**
rielaborazione del classico
modello a cipolla dei mobili di
inizio secolo scorso.

Elegant feet inspired by the
classic 'onion' model of early
1900.

Inspiration



ELEGANCE BENCH

DESIGN | PAOLO CASTELLI



Wood Painted
Matt Gold



Fabric
Velvet Superior Mana
Col. Green Grey

Elegance Bench è un imbottito dalle forme lineari, ideali da bordo del letto ma valide anche per ingressi e camere guardaroba. Ha una struttura interna in multistrato di legno con imbottitura in poliuretano a densità variabile.

E' decorato con cuscini cilindrici e i piedini sono in metallo con finitura oro opaco. E' personalizzabile con pregiati tessuti, raffinati pelli bovine pieno fiore e nubuk.

Elegance Bench is a padded chair with an elegant design. Ideal in entrances, living spaces, wardrobe areas and bedrooms.

The structure is made of multi-layer wood with padding made in different density expanded polyurethane. It is decorated with a cylindrical cushion and the metal feet have a matt gold finish. The product can be personalized in a wide range of elegant fabrics, fine leather and nubuck.

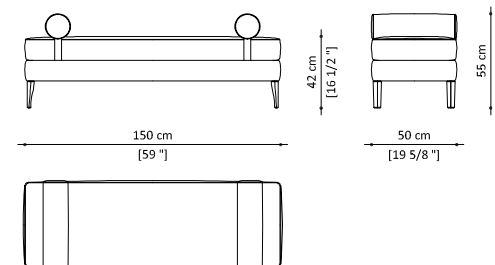

ECOLEATHER | SED.ELEG.400.ECO
Eco-Friendly Leather

FABRIC SUPERIOR | SED.ELEG.400.SUP
Fabric Superior

FABRIC DELUXE | SED.ELEG.400.DEL
Fabric Deluxe

LEATHER | SED.ELEG.400.PEL
Bovine Leather

NABUK | SED.ELEG.400.NAB
Nabuk

(2 round cushions included)

Inspiration



ORUS BENCH

DESIGN | PAOLO CASTELLI



Metal Finish
Matt Gold



Nabuk
Col. 16 Brown

Orus bench ha forme seducenti ed avvolgenti dal richiamo "belle époque". Perfetta per ingressi, ambienti da conversazione o privati, consta di una struttura interna in multistrato di legno curvato con imbottitura in poliuretano a densità variabile. Ha un rivestimento, non sfoderabile, personalizzabile con pregiati tessuti, raffinate pelli bovine pieno fiore e nabuk. La panca poggia su di una preziosa struttura in metallo con gambe disposte ad incrocio, arricchite con preziosa finitura oro opaco.

Orus bench owns enchanting and embracing shapes recalling the "belle-époque" charme. Ideal for conversation or private living spaces, it consists in a curved multilayer wooden internal structure, the padding is made from different density expanded polyurethane. The non removable cover can be personalized with graceful fabrics, refined bovine grain leather and nubuck. The bench lies on a precious all-metal structure with criss-crossed legs enriched by a precious mat gold finish.

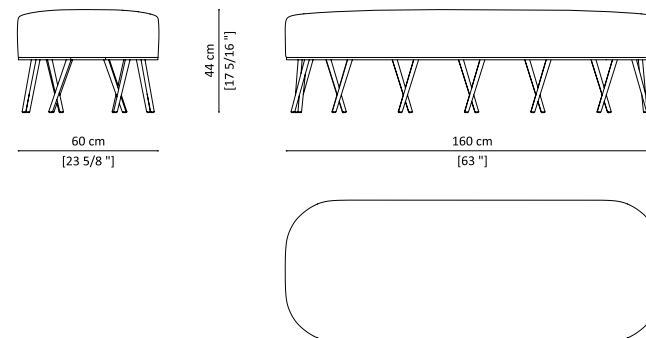

FABRIC SUPERIOR | SED.ORUS.400.SUP

Matt gold metal base
Fabric Superior

FABRIC DELUXE | SED.ORUS.400.DEL

Matt gold metal base
Fabric Deluxe

LEATHER | SED.ORUS.400.PEL

Matt gold metal base
Bovine Leather

NABUK | SED.ORUS.400.NAB

Matt gold metal base
Nabuk

Inspiration

C

VENICE SOFA

DESIGN | PAOLO CASTELLI



Wood Painting
Pearl Beige
Ral 1035



Natural Leather
Col. 634 Oasi

Venice Sofa è un divanetto imbottito dalle forme morbide e contenute che lo rendono adatto a tutti gli ambienti del vivere contemporaneo.

È realizzato con una struttura interna in multistrato di legno curvato con imbottitura in poliuretano a densità variabile.

Ha un rivestimento, non sfoderabile, personalizzabile con pregiati tessuti, raffinate pelli bovine pieno fiore, e nabuk. Il divano poggia su una struttura in legno laccato con vernice metallica color beige perlato Ral 1035.

Venice Sofa is a small padded sofa with a soft looking shape that makes it ideal for any contemporary living space.

Its structure is made of curved multi-layer wood padded with different density polyurethane. Its cover, which cannot be removed, can be personalised in a wide range of elegant fabrics, fine leather and nubuck. The sofa base is made of wood painted with a metal finish pearl beige Ral 1035.

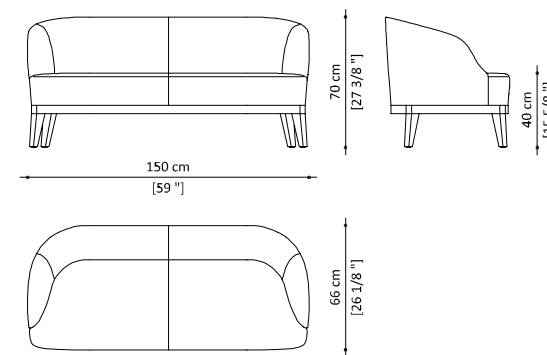

ECOLEATHER | SED.VENI.100.ECO

Base in wood matt pearl beige painted Ral 1035
Eco-Friendly Leather

FABRIC SUPERIOR | SED.VENI.100.SUP

Base in wood matt pearl beige painted Ral 1035
Fabric Superior

FABRIC DELUXE | SED.VENI.100.DEL

Base in wood matt pearl beige painted Ral 1035
Fabric Deluxe

LEATHER | SED.VENI.100.PEL

Base in wood matt pearl beige painted Ral 1035
Bovine Leather

NABUK | SED.VENI.100.NAB

Base in wood matt pearl beige painted Ral 1035
Nabuk

Inspiration



VENICE BENCH & POUF

DESIGN | PAOLO CASTELLI



Wood Painting
Pearl Beige
Ral 1035



Fabric Deluxe
Orfe Col. 0637
Ivory



Wood
Painted
Black



Fabric Decorative
Myrrhe Col. 01
Gold

Completano la gamma della famiglia Venice le declinazioni bench e pouf. Entrambi poggiamo su una struttura in legno di faggio verniciato con imbottitura in poliuretano a densità variabile e hanno un rivestimento, non sfoderabile, personalizzabile con pregiati tessuti, raffinate pelli bovine pieno fiore e nabuk.

The bench and pouf complete the range of the Venice family. Both rest on a lacquered beech wood structure padded with different density polyurethane, covered with non removable covers that can be customised with fine fabrics, refined full grain cowhide and nubuck leather.

BENCH

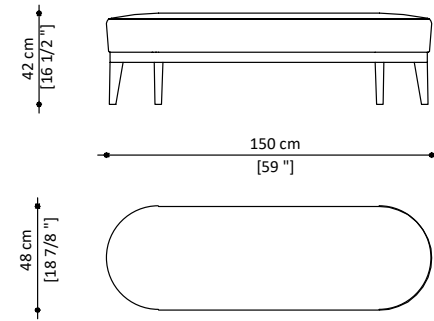

ECOLEATHER | SED.VENI.400.ECO

Base in wood matt pearl beige painted Ral 1035
Eco-Friendly Leather

FABRIC SUPERIOR | SED.VENI.400.SUP

Base in wood matt pearl beige painted Ral 1035
Fabric Superior

FABRIC DELUXE | SED.VENI.400.DEL

Base in wood matt pearl beige painted Ral 1035
Fabric Deluxe

LEATHER | SED.VENI.400.PEL

Base in wood matt pearl beige painted Ral 1035
Bovine Leather

NABUK | SED.VENI.400.NAB

Base in wood matt pearl beige painted Ral 1035
Nabuk

POUF

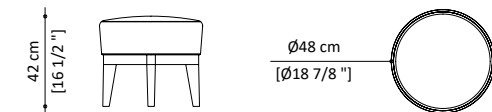

ECOLEATHER | SED.VENI.500.ECO

Base in wood matt black painted
Eco-Friendly Leather

FABRIC SUPERIOR | SED.VENI.500.SUP

Base in wood matt black painted
Fabric Superior

FABRIC DELUXE | SED.VENI.500.DEL

Base in wood matt black painted
Fabric Deluxe

LEATHER | SED.VENI.500.PEL

Base in wood matt black painted
Bovine Leather

NABUK | SED.VENI.500.NAB

Base in wood matt black painted
Nabuk

POLTRONE ARMCHAIRS

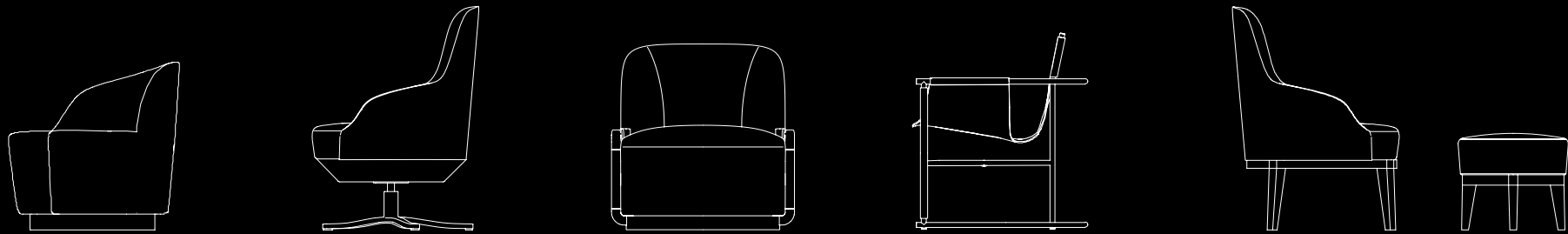

Inspiration



U CHAIR

DESIGN | VITTORIO PARADISO



Metal Finish
Black Nickel
Polished



Leather
Col. Natural



Metal Finish
Polished
Gold



Leather
Col. Beige

Raffinata poltroncina i cui principali punti di forza sono la comodità e la forte personalità, che si uniscono a formare soluzioni estetiche e strutturali di grande impatto.

La forma invitante è definita da una profondità accentuata e da un fronte leggermente inclinato. La struttura, che avvolge elegantemente il corpo, è disponibile in finitura lucida nichel nero oppure oro, con rivestimenti in cuoio color beige, naturale o nero, e cuciture a vista. La seduta invece appare come sospesa, fluttuante, poiché semplicemente calzata nello schienale e infilata nei braccioli. Braccioli in cuoio in tinta con i rivestimenti della struttura.

A refined chair the main strengths of which are comfort and great personality, combining to form high-impact aesthetic and structural solutions.

The alluring shape is outlined by an accentuated depth and a slightly tilted front.

The structure elegantly embraces the body and comes in polished metal, black nickel and gold finishes, with beige-coloured leather upholstery featuring visible stitching (also available black or natural leather). The seat fits simply into the backrest and slots into the armrests, making it look almost as though it is suspended, floating. Available in leather with matching armrests.

/ 138

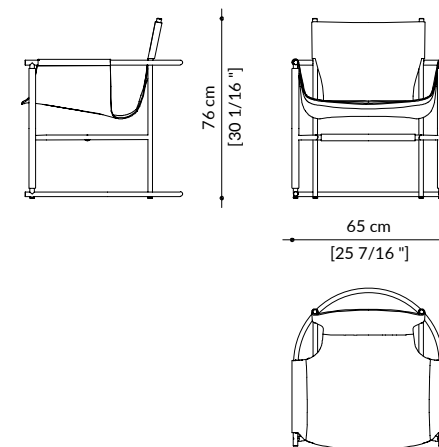

BLACK NICHEL POLISHED | SED.UCHA.700.PEL

Metal frame Black Nichel polished

Seat, back and frame details made in leather - Available colours Natural leather or sand

POLISHED GOLD | SED.UCHA.710.PEL

Metal frame Polished Gold

Seat, back and frame details made in leather - Available colours Natural leather or sand



◀ La seduta in cuoio appare
come sospesa, perché calzata
nello schienale e nei braccioli.

Suspended seat, hanged both
to the back and the armrests.

Inspiration

C

PARABOLICA ARMCHAIR

DESIGN | VITTORIO PARADISO



**Metal Finish
Polished
Brass**



**Fabric Deluxe
Jacquard Twist
CA 1570/071**



**Fabric Deluxe
Jacquard Twist
CA 1570/082**

Parabolica Armchair è una poltroncina lussuosa, adatta a zone lounge e di attesa, ingressi e zone living, ideale per conversare. La seduta si distingue per la forma della struttura che ha l'effetto di una curva parabolica, da cui ne deriva il nome.

Caratterizzata da un sofisticato telaio in metallo con trattamento galvanico oro lucido, la seduta è realizzata con una comoda imbottitura in poliuretano espanso sagomato a quote differenziate e con braccioli e cuscinetto in piuma d'oca rivestiti in pelle color beige. Il rivestimento, non sfoderabile, è personalizzabile con eleganti tessuti, pregiata pelle bovina e nabuk.

Parabolica Armchair is a delicate size luxury seat, suitable in lounging and waiting areas, entrances and living spaces, ideal for conversation. It stands out for the shape of the seat that has the effect of a parabola, from which it takes its name.

Defined by a sophisticated metal structure with a polished gold galvanic finish, the armchair is padded with different density expanded polyurethane and the armrests and the goose feather little cushion are covered in beige bovine leather.

The non-removable cover can be customized with elegant fabrics, fine leather and nubuck.

ARMCHAIR

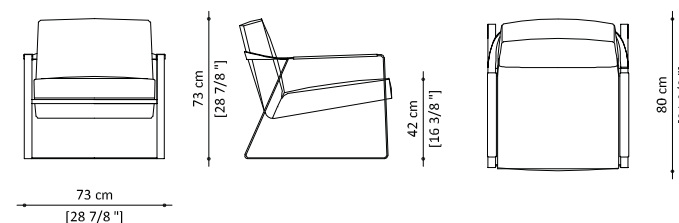

ECOLEATHER | SED.PARA.200.ECO

Metal base polished gold
Eco-Friendly Leather

FABRIC SUPERIOR | SED.PARA.200.SUP

Metal base polished gold
Fabric Superior

FABRIC DELUXE | SED.PARA.200.DEL

Metal base polished gold
Fabric Deluxe

LEATHER | SED.PARA.200.PEL

Metal base polished gold
Bovine Leather

NABUK | SED.PARA.200.NAB

Metal base polished gold
Nabuk

OTTOMAN

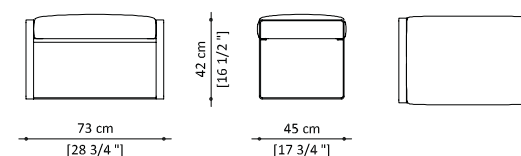

ECOLEATHER | SED.PARA.500.ECO

Metal base polished gold - Eco-Friendly Leather

FABRIC SUPERIOR | SED.PARA.500.SUP

Metal base polished gold - Fabric Superior

FABRIC DELUXE | SED.PARA.500.DEL

Metal base polished gold - Fabric Deluxe

LEATHER | SED.PARA.500.PEL

Metal base polished gold - Bovine Leather

NABUK | SED.PARA.500.NAB

Metal base polished gold - Nabuk



CE



◀ **Curvatura parabolica
della struttura realizzata
artigianalmente da un unico
pezzo.**

Parabolic curve of the
structure handcrafted from a
unique piece.

Inspiration

C

VENICE ARMCHAIR

DESIGN | PAOLO CASTELLI



Wood Painting
Pearl Beige
Ral 1035



Natural Leather
Col. 634 Oasi

Venice Armchair è una comoda poltroncina imbottita, dalle forme morbide e contenute, adatta a tutti gli ambienti del vivere contemporaneo.

È realizzata con una struttura interna in multistrato di legno curvato con imbottitura in poliuretano a densità variabile. Ha un rivestimento, non sfoderabile, personalizzabile con pregiati tessuti, raffinate pelli bovine pieno fiore e nabuk. La seduta poggia su una struttura in legno laccato con vernice metallica color beige perlato RAL 1035.

Venice Armchair is a small padded seat with a soft looking shape that makes it ideal for any contemporary living space.

Its structure is made of curved multi-layer wood padded with different density polyurethane. Its cover, which cannot be removed, can be personalized in a wide range of elegant fabrics, fine leather and nubuck. The armchair base is made of wood painted with a pearl-beige metal finish. RAL 1035.

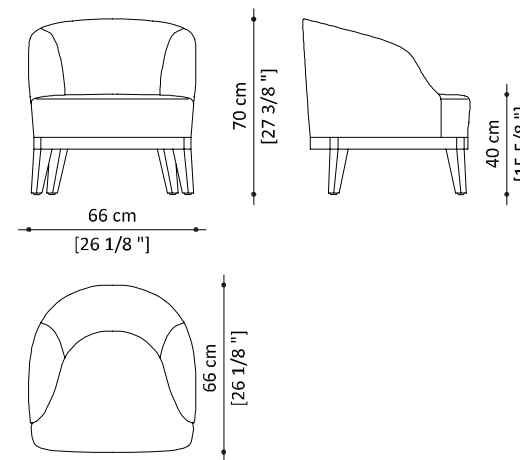

ECOLEATHER | SED.VENI.210.ECO

Pearl beige varnished legs
Eco-Friendly Leather

FABRIC SUPERIOR | SED.VENI.210.SUP

Pearl beige varnished legs
Fabric Superior

FABRIC DELUXE | SED.VENI.210.DEL

Pearl beige varnished legs
Fabric Deluxe

LEATHER | SED.VENI.210.PEL

Pearl beige varnished legs
Bovine Leather

NABUK | SED.VENI.210.NAB

Pearl beige varnished legs
Nabuk



◀ **Confort e versatilità di utilizzo soprattutto in ambito contract.**

Ideal in contract commissions for his comfort and versatility.

Inspiration

C

VENICE BERGERE

DESIGN | PAOLO CASTELLI

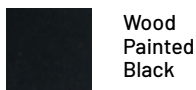

Wood
Painted
Black



Fabric Superior
Velvet Sig Col. 03
Dark Blue

Poltrona dalle linee avvolgenti e dall'alto schienale che amplia la collezione Venice. Adatta in salotto come nella zona night, è caratterizzata da una struttura interna in multistrato di legno curvato con imbottitura in poliuretano a densità variabile. Ha un rivestimento, non sfoderabile, personalizzabile con pregiati tessuti, raffinate pelli bovine pieno fiore e nubuk. La seduta poggia su una struttura in legno di faggio verniciato nero opaco.

Armchair with enveloping lines and high-backed which expands the Venice collection. Suitable for the living room as for the night zone, is characterized by an internal structure in curved wood with padding in variable-density polyurethane-finishing. It has a non-removable cover customizable with fine fabrics, fine full-grain leather and nubuk finishing. The seat rests on a wooden beech frame with dark mat finishing.

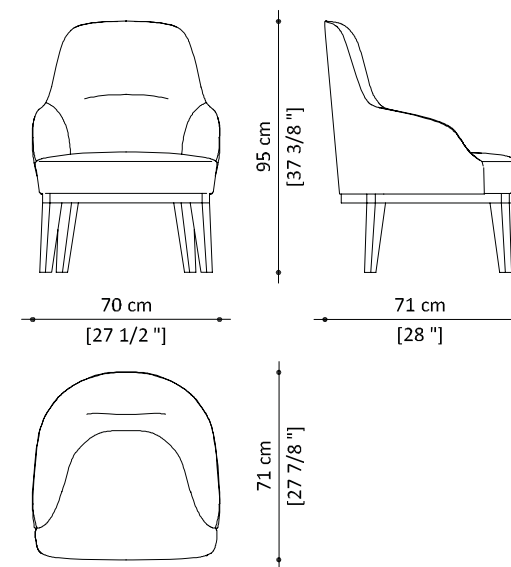

ECOLEATHER | SED.VENI.220.ECO

Black mat varnished legs
Eco-Friendly Leather

FABRIC SUPERIOR | SED.VENI.220.SUP

Black mat varnished legs
Fabric Superior

FABRIC DELUXE | SED.VENI.220.DEL

Black mat varnished legs
Fabric Deluxe

LEATHER | SED.VENI.220.PEL

Black mat varnished legs
Bovine Leather

NABUK | SED.VENI.220.NAB

Black mat varnished legs
Nabuk



C



VENICE SWING ARMCHAIR

DESIGN | PAOLO CASTELLI



Metal Finish
Matt Gold



Fabric Decorative
Myrrhe Col. 04 Grey



Fabric Superior
Velvet Sig
Col. 29 Beige

Poltrona dalle linee avvolgenti e dall'alto schienale che amplia la collezione Venice. Adatta in salotto come nella zona night, è caratterizzata da una struttura interna in multistrato di legno curvato con imbottitura in poliuretano a densità variabile. Ha un rivestimento, non sfoderabile, personalizzabile con pregiati tessuti, raffinate pelli bovine pieno fiore e nabuk. La seduta poggia su un basamento girevole in laminato metallico oro satinato opaco, completo di meccanismo di ritorno.

An armchair with enveloping lines and a high backrest. This addition to the Venice collection is as well-suited to the living room as it is to the bedroom and features an internal structure in shaped plywood with variable density polyurethane padding and a customisable non removable cover available in fine fabrics, refined full grain cowhide and nubuck leather. The seat is mounted on a swivel base of matt satin finish gold metal laminate with return mechanism.

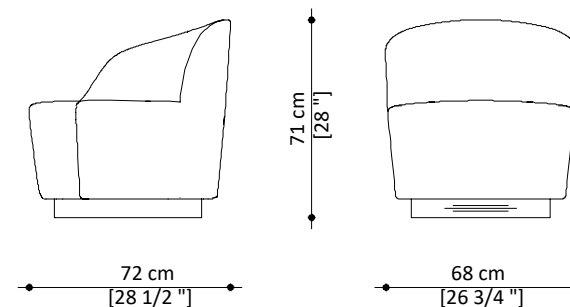

ECO-LEATHER | SED.VENI.230.ECO
Eco-Friendly Leather

FABRIC SUPERIOR | SED.VENI.230.SUP
Fabric Superior

FABRIC DELUXE | SED.VENI.230.DEL
Fabric Deluxe

LEATHER | SED.VENI.230.PEL
Bovine Leather

NABUK | SED.VENI.230.NAB
Nabuk



C



◀ **La seduta poggia su un basamento girevole con meccanismo di ritorno nella posizione iniziale.**

The seat lies on a swivel base with return mechanism to initial position.

Inspiration



LADY PEACOCK ARMCHAIR

DESIGN | CRISTIANO GATTO



Fabric Superior
Velvet Mana
Col. 0714 Beige



Wood
Dark Oak



Metal Finish
Matt Gold

Eleganza inglese per una poltroncina raffinata e contemporanea, il cui elemento caratteristico è il bracciolo in rovere tinto scuro che avvolge lo schienale. È realizzata con una struttura interna in multistrato di legno curvato con imbottitura in poliuretano a densità variabile. Ha un rivestimento non sfoderabile personalizzabile con pregiati tessuti, raffinate pelli bovine pieno fiore e nabuk. La seduta poggia su una base in legno color rovere tinto scuro rivestita con profilo metallico con finitura oro opaco, o su richiesta è disponibile la base interamente realizzata in legno finitura rovere tinto scuro.

English noblesse for a refined and contemporary chaise whose main feature is the armrest in dark stained oak embracing its back. Realised with an internal multi layer curved wooden structure padded with different density expanded polyurethane. The non removable upholstery can be personalised with noble fabrics, fine bovine grain leather and nubuck. The seat lies on a wooden base dark oak finished covered with a metal profile mat gold finished, or in alternative in wood dark oak finish.

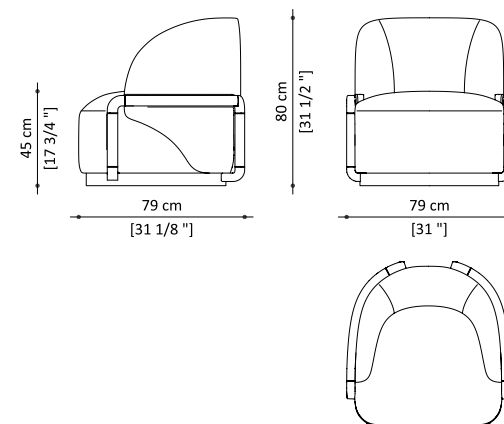

SUPERIOR | SED.LPEA.200.SUP

Base in oak finish with mat gold metal detail - Fabric Superior

DELUXE | SED.LPEA.200.DEL

Base in oak finish with mat gold metal detail - Fabric Deluxe

LEATHER | SED.LPEA.200.PEL

Base in oak finish with mat gold metal detail - Bovine Leather

NABUCK | SED.LPEA.200.NAB

Base in oak finish with mat gold metal detail - Nabuk

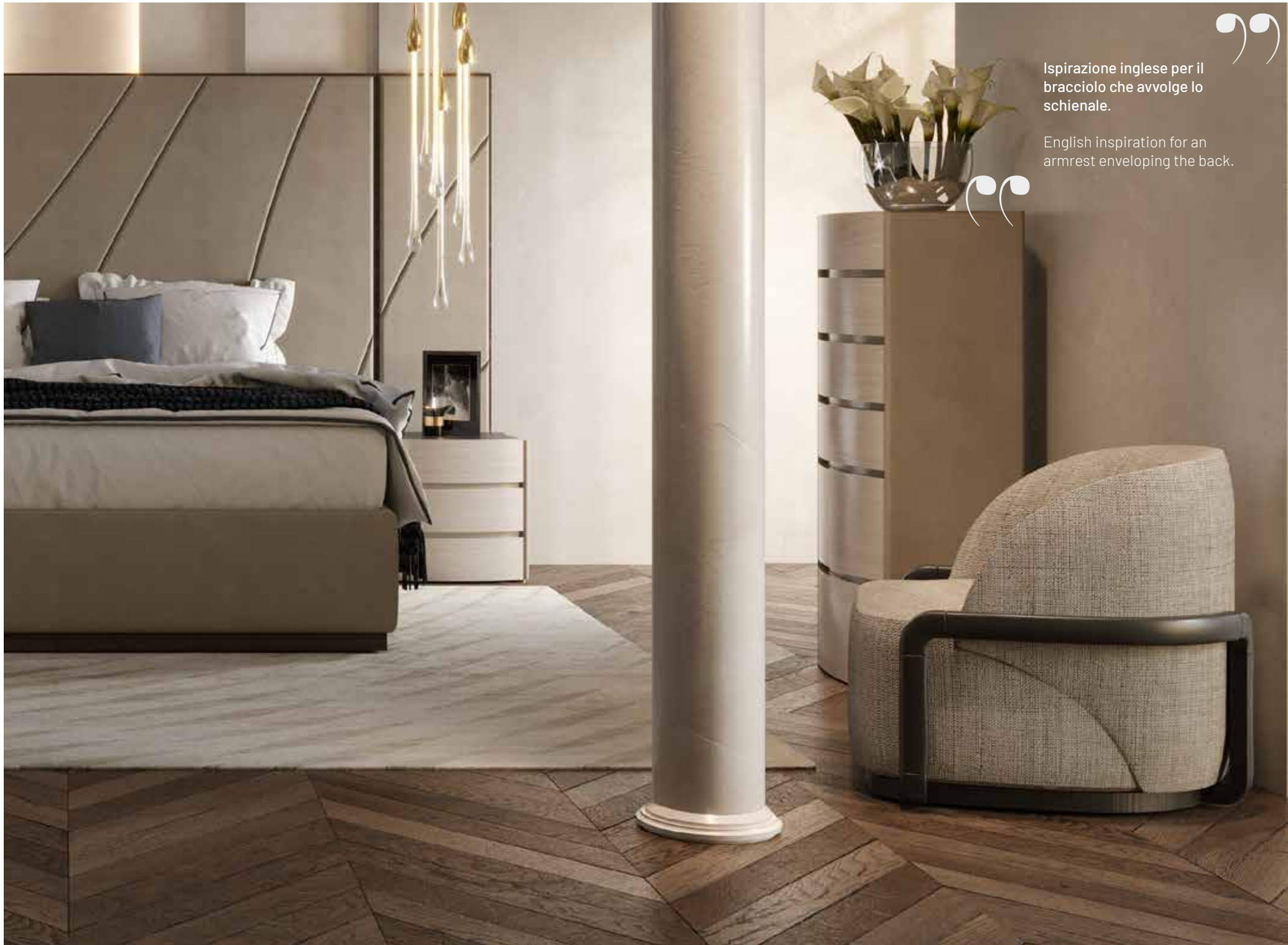

”
Ispirazione inglese per il
bracciolo che avvolge lo
schienale.

English inspiration for an
armrest enveloping the back.

Inspiration

C

ELEGANCE ARMCHAIR

DESIGN | PAOLO CASTELLI



Wood Painting
Matt Gold



Fabric Deluxe
Col. Pearl

Si compone di una struttura interna in acciaio e multistrato di legno con imbottitura e cuscineria in poliuretano a densità variabile. I piedini sono in metallo con finitura oro opaco. Elegance Armchair è personalizzabile con pregiati tessuti, raffinati pelli bovine pieno fiore e nabuk.

The structure is made of steel and multi-layer wood while the padding and cushions are stuffed with different density expanded polyurethane. The metal feet have a matt gold finish. Elegance Armchair can be personalized in a wide range of elegant fabrics, fine leather and nubuck.

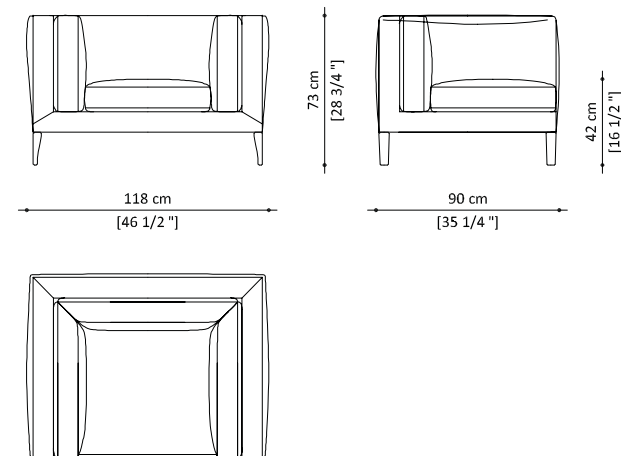

ECOLEATHER | SED.ELEG.200.ECO
Eco-Friendly Leather

FABRIC SUPERIOR | SED.ELEG.200.SUP
Fabric Superior

FABRIC DELUXE | SED.ELEG.200.DEL
Fabric Deluxe

LEATHER | SED.ELEG.200.PEL
Bovine Leather

NABUK | SED.ELEG.200.NAB
Nabuk



C

◀ **Elegante piedino
rielaborazione del classico
modello a cipolla dei mobili di
inizio secolo scorso.**

Elegant feet inspired by the
classic 'onion' model of early
1900.

Inspiration



DROMO ARMCHAIR

DESIGN | PAOLO CASTELLI



Wood
Dark Oak



Matt
Brass



Fabric Superior
Velvet Mana
Col. 0714 Dove

Dromo poltrona nasce come omaggio al grande maestro Carlo Scarpa e alla sua città. Si presenta come una piattaforma sospesa, dove il volume importante della cuscineria è reso più leggero dalla struttura in rovere massello tinto scuro, impreziosita dagli elementi esagonali in ottone naturale satinato. Il rivestimento è in pelle, nubuck o tessuto con piping in tessuto col. marrone (Ref. Fabric Sateen D6037815 Brown) o in tinta.

Cuscineria sedile e schienale sfoderabile, imbottitura in poliuretano espanso sagomato a quote differenziate.

Dromo armchair born as a tribute to the great master Carlo Scarpa and his town. It appears like a suspended platform where the significant volume of the cushions is rendered lighter by the structure in solid oak dark painted. It is enriched by precious details such as the hexagonal elements in natural satin brass on the legs of the structure. The upholstery is in leather, nubuck or fabric with piping in fabric col. brown (Ref. Fabric Sateen D6037815 Brown) or matching.

Removable covering for seat and back cushions, padding in different density expanded polyurethane.

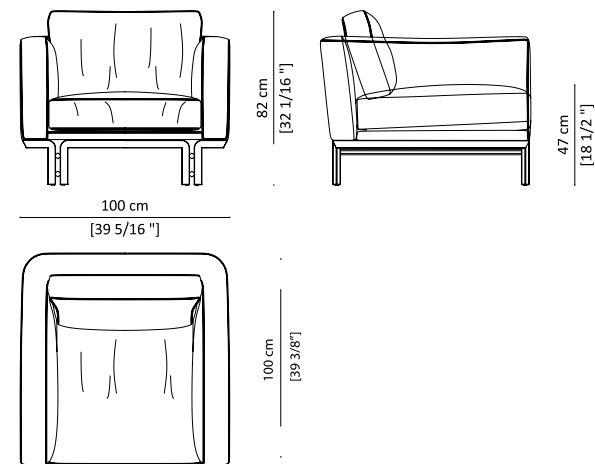

FABRIC SUPERIOR | SED.DROM.200.SUP

Base in oak finish - Mat brass detail
Fabric Superior

FABRIC DELUXE | SED.DROM.200.DEL

Base in oak finish - Mat brass detail
Fabric Deluxe

LEATHER | SED.DROM.200.PEL

Base in oak finish - Mat brass detail
Bovine Leather

NABUK | SED.DROM.200.NAB

Base in oak finish - Mat brass detail
Nabuk



◀ **Elementi esagonali in ottone naturale satinato.**

Hexagonal details in matte natural brass.

Inspiration



GARIBALDI ARMCHAIR

DESIGN | LUCA SCACCHETTI



Wood
Dark Oak



Natural Leather
Col. 674 Siena



Natural Leather
Col. 602 Dark Brown

Il telaio interno è realizzato in massello d'abette multistrato di pino cileno, con inserto interno composto da cinghie elastiche e imbottitura con schiuma poliuretanicamente espansa indeformabile, di densità a quote differenziate, e ricoperto da una soffice trapunta in cotone 100% imbottita con piuma d'oca per aumentarne il confort. Il design offre un profilo ben disegnato con il taglio a vista della pelle pieno fiore spessorata, mentre la versione in tessuto è impreziosita da una doppia orlatura.

Its structure is multi-layer solid chilean pine wood, with an internal system of elastic bands padded with expanded polyurethane crushproof foam entirely covered by a soft quilt of 100% cotton, added with goose down for additional comfort.

The leather version boasts a well-defined profile thanks to its cut, while the fabric version, with non-removable cover, is enriched by a double seam.

ARMCHAIR

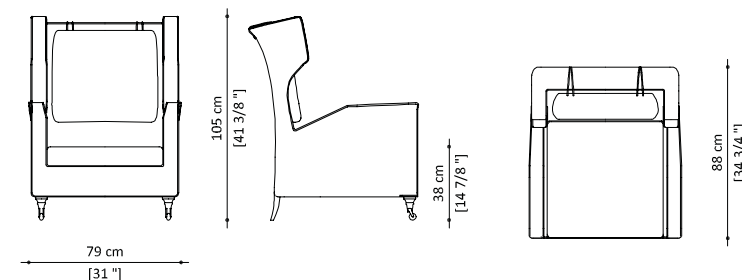

ECOLEATHER | SED.GARI.200.ECO
Eco-Friendly Leather

LEATHER | SED.GARI.200.PEL
Bovine Leather

NABUK | SED.GARI.200.NAB
Nabuk

POUF MAXI

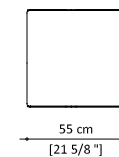

ECOLEATHER | SED.GARI.500.ECO
Eco-Friendly Leather

LEATHER | SED.GARI.500.PEL
Bovine Leather

NABUK | SED.GARI.500.NAB
Nabuk

Inspiration



FLUON ARMCHAIR

DESIGN | MASSIMO IOSA GHINI



Nabuck
Col. 37 Ardesia

Il telaio interno è realizzato in massello d'abete multistrato di pino cileno, con inserto interno composto da cinghie elastiche e imbottitura con schiuma poliuretanicata espansa indeformabile, di densità a quote differenziate, e ricoperto da una soffice trapunta in cotone 100% imbottita con piuma d'oca per aumentarne il confort. Il design offre un profilo ben disegnato con il taglio a vista della pelle pieno fiore spessorata, mentre la versione in tessuto è impreziosita da una doppia orlatura.

Its structure is multi-layer solid chilean pine wood, with an internal system of elastic bands padded with expanded polyurethane crushproof foam entirely covered by a soft quilt of 100% cotton, added with goose down for additional comfort.

The leather version boasts a well-defined profile thanks to its cut, while the fabric version, with non-removable cover, is enriched by a double seam.

ARMCHAIR

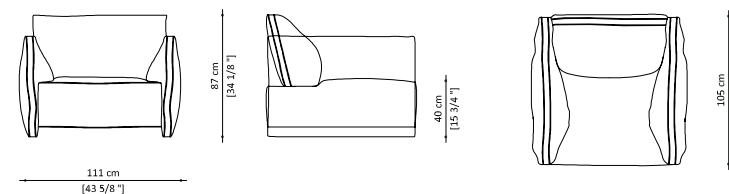

FABRIC SUPERIOR | SED.FLUO.200.SUP

Fabric Velvet Superior

FABRIC DELUXE | SED.FLUO.200.DEL

Fabric Hammered Velvet

NABUK | SED.FLUO.200.NAB

Nabuk

POUF MINI

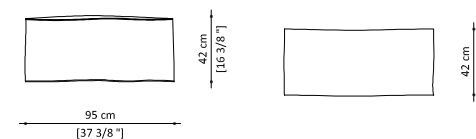

FABRIC SUPERIOR | SED.FLUO.510.SUP

Fabric Velvet Superior

FABRIC DELUXE | SED.FLUO.510.DEL

Fabric Hammered Velvet

NABUK | SED.FLUO.510.NAB

Nabuk

POUF MAXI

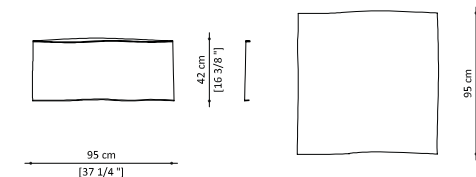

FABRIC SUPERIOR | SED.FLUO.520.SUP

Fabric Velvet Superior

FABRIC DELUXE | SED.FLUO.520.DEL

Fabric Hammered Velvet

NABUK | SED.FLUO.520.NAB

Nabuk

Inspiration

C

DURBAN ARMCHAIR

DESIGN | SAMUELE MAZZA



Wood
Elm Grey



Fabric Superior
Blended linen
col. Gog Ivory

Forme avvolgenti e confortevoli. Poltrona con struttura in legno di olmo cenere che "incastona" la soffice seduta, rivestita in pregiati tessuti o pelli. L'imbottitura dello schienale è in poluretano espanso sagomato a quote differenziate e predisposta con 2 cuscini fissi cui si aggiungono 2 mobili. La poltrona ha piping in tessuto col. marrone in tinta con la base.

Wrapping and comfortable shapes. Armchair with an elm ash wood structure that "embeds" the soft seat, upholstered in precious fabrics or leathers. The back padding is made in different density expanded polyurethane and arranged with 2 fixed cushions to which 2 pieces of furniture are added. Brown colored piping in fabric matches the base.

ARMCHAIR

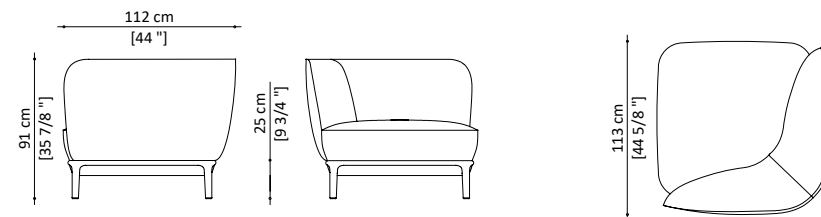

FABRIC SUPERIOR | SED.DURB.210.SUP

Base in ash elm wood 0 gloss - Piping fabric col. Dark brown
Fabric Superior

FABRIC DELUXE | SED.DURB.210.DEL

Base in ash elm wood 0 gloss - Piping fabric col. Dark brown
Fabric Deluxe

LEATHER | SED.DURB.210.PEL

Base in ash elm wood 0 gloss - Piping fabric col. Dark brown
Bovine Leather

NABUK | SED.DURB.210.NAB

Base in ash elm wood 0 gloss - Piping fabric col. Dark brown
Nabuk

(including 2 movable cushions)

OTTOMAN

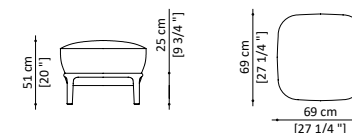

FABRIC SUPERIOR | SED.DURB.510.SUP

Base in ash elm wood 0 gloss - Piping fabric col. Dark brown
Fabric Superior

FABRIC DELUXE | SED.DURB.510.DEL

Base in ash elm wood 0 gloss - Piping fabric col. Dark brown
Fabric Deluxe

LEATHER | SED.DURB.510.PEL

Base in ash elm wood 0 gloss - Piping fabric col. Dark brown
Bovine Leather

NABUK | SED.DURB.510.NAB

Base in ash elm wood 0 gloss - Piping fabric col. Dark brown
Nabuk



C

◀ Ideale per vestire gli angoli di ingressi o aree living.

Perfect for furnishing halls and living areas.



Inspiration



VENICE OFFICE

DESIGN | PAOLO CASTELLI



Metal Finish
Black Nickel
Polished



Nabuk
Col. 15
Taupe

Poltrona che amplia la collezione Venice con questa proposta da ufficio dalle linee avvolgenti e dall'alto schienale. Struttura interna in multistrato di legno curvato con imbottitura in poliuretano a densità variabile. Ha un rivestimento, non sfoderabile, personalizzabile con pregiati tessuti, raffinate pelli bovine pieno fiore e nabuk. La seduta poggia su una base metallica color nichel nero lucido.

An armchair with enveloping lines and a high backrest designed for office spaces. This addition to the Venice collection features an internal structure in shaped plywood with variable density polyurethane padding and a customisable non removable cover, available in fine fabrics, refined full grain cowhide and nubuck leather. The seat is mounted on a shiny black nickel metal base.

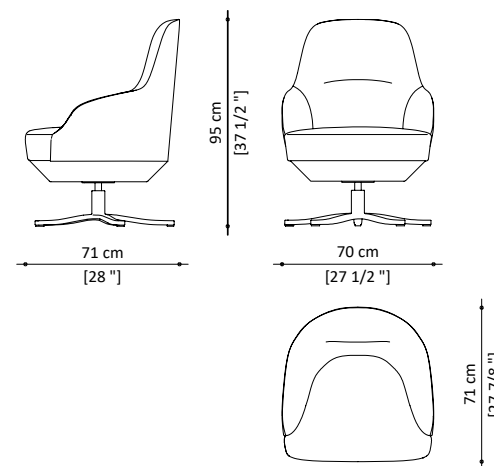

ECOLEATHER | SED.VENI.240.ECO

Black nickel metal base
Eco-Friendly Leather

LEATHER | SED.VENI.240.PEL

Black nickel metal base
Bovine Leather

NABUK | SED.VENI.240.NAB

Black nickel metal base
Nabuk



CONTENITORI STORAGE

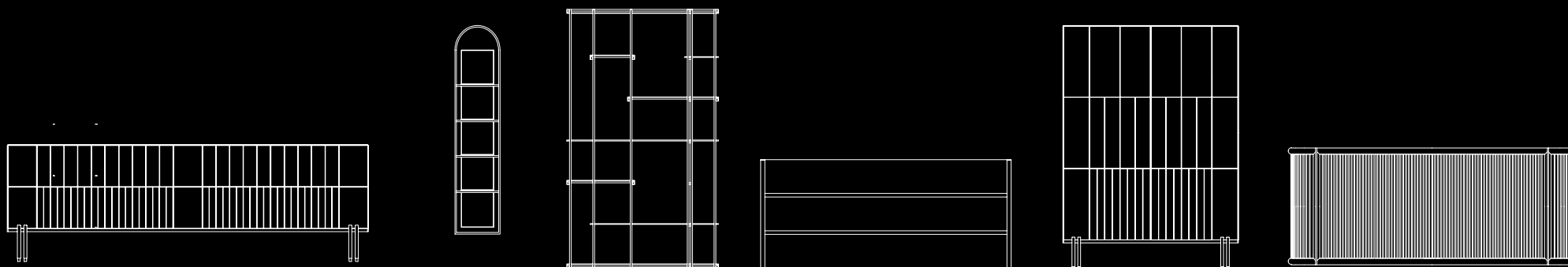

Inspiration

UFFIZIO BOOKCASE

DESIGN | VITTORIO PARADISO



Grey Mirrored
Glass Matt



Metal Finish
Bronze
Shadow Matt



Transparent
glass col. Avana

Libreria luminosa da parete composta da struttura in metallo finitura Bronze Shadow opaco disponibile anche con LED integrato, 4 ripiani in vetro trasparente col. Avana e schiena a specchio grigio satinato. Completa di fissaggio a parete. Su richiesta è disponibile la versione con 3 ripiani, per alloggiare oggetti più alti.

Wall-mounted illuminated bookcase consisting of a metal structure with a matt Bronze Shadow matt finish, available with or without LED system incorporated, with four transparent glass shelves col. Avana and a satin-finish grey mirrored glass matt back. Complete with wall fixture. On request is available the model with 3 shelves, to storage tall objects.



archiproducts
DESIGN AWARDS
WINNER 2020

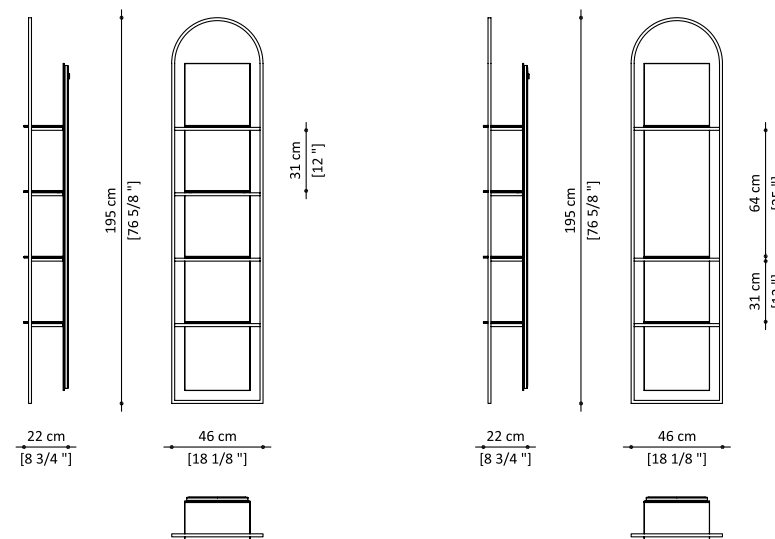

BOOKCASE | LIB.UFF I.500

Metal frame Bronze Shadow matt finished - Shelves in transparent glass col. Avana
Wall panel made in grey mirrored glass matt

BOOKCASE WITH LED | LIB.UFF I.510

Metal frame Bronze Shadow matt finished - Shelves in transparent glass col. Avana
Wall panel made in grey mirrored glass matt - LED strip



Moderna e accattivante libreria luminosa.

Modern and charming backlit bookcase.

AEREM BOOKCASE

DESIGN | PAOLO CASTELLI



Satined
Brass



Extraclear
glass



Mirror
glass

Libreria a pavimento autoportante in vetro trasparente extraclear di spessore 10 mm e profilo perimetrale su entrambi i lati in ottone satinato. Arem è un complemento dal design contemporaneo che affascina con l'uso minimale dei materiali. La forma chiara e simmetrica, gli angoli retti e l'omissione di parti non necessarie creano un'impressione di assenza di gravità, mentre la vera bellezza degli scaffali sta nei loro giochi con la luce naturale e artificiale. Il ripiano inferiore è rivestito in specchio.

Free-standing bookcase made of extra-clear transparent glass, 10 mm thick, with satin brass finish metal perimeter profile on both sides. Arem is a contemporary piece of furniture designed with a captivating minimal use of materials. Its clear, symmetrical shape, right angles and absence of unnecessary parts create an impression of weightlessness, while the shelves' true beauty lies in the natural and artificial light effects they create. Lower shelf is covered by mirror.

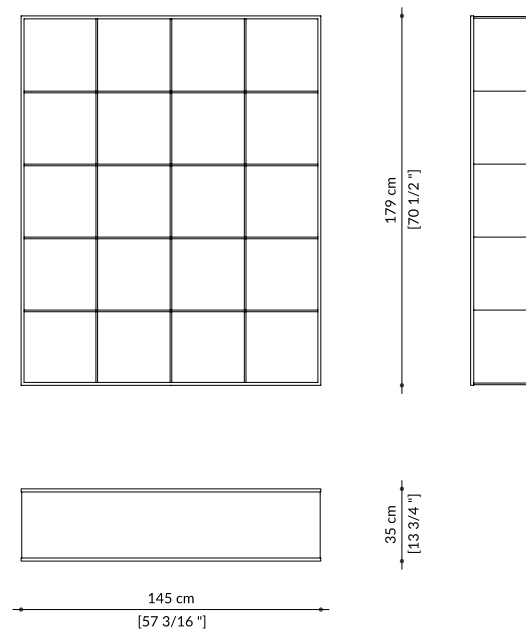

AEREM BOOKCASE | LIB.AERE.500

Extraclear trasparente glass - Satined brass details (on both two sides)

Inspiration

SAGGIO BOOKSHELF

DESIGN | ANGELO MICHELI



Metal Finish
Matt Gold



Wood
Dark oak

Saggio bookcase è il luogo ideale per custodire ed apprezzare la bellezza dei libri che, ordinatamente esposti, rivelano la sensibilità e gusti di chi li possiede. Saggio Bookcase è realizzata con struttura in mdf impiallacciato in rovere spessorato e bordature dei profili e dello zoccolo laminati in oro opaco. Per dare un effetto di movimento, i montanti verticali sono realizzati in differenti profondità. L'apertura sui fianchi è pantografata secondo un decoro sinuoso che ne spezza il ritmo regolare. Ideale la composizione di più elementi affiancati tra loro.

Saggio Bookcase is ideal to store and showcase neatly arranged books, which reveal the taste and sensitivity of their owner.

The structure is in shimmied oak, while the shelf edges and base are matt gold laminate. The vertical panels have different depths to provide a dynamic effect. The decorative curvy opening on the sides breaks the regularity of the shape. Ideal combined side by side with other elements.

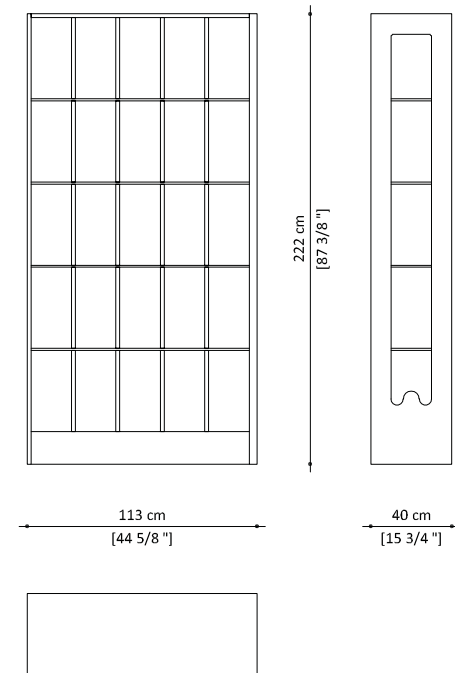

SAGGIO | LIB.SAGG.500
Dark oak wood

Inspiration



SOCRATE BOOKSHELF

DESIGN | PAOLO CASTELLI



Metal Finish
Matt Gold



Marble
Rosa Egeo



Transparent
glass col. Avana

Alternative
shelves option



Wood
Elm Grey

Alternative
structure option



Metal Finish
Bronze
Shadow Matt

Socrate Bookshelf è realizzata con struttura metallica composta da tubolari a sezione quadrata. La versione in marmo ha la struttura metallica in finitura oro opaco, ripiani realizzati in vetro color avana e marmo Rosa Egeo. La versione in legno ha la struttura metallica in finitura Bronze Shadow opaco, ripiani in vetro Antelio color avana e legno di olmo cenere. Disponibili i modelli Socrate 35 e Socrate 130.

Socrate Bookshelf is made with a metal structure composed of square section tubulars. The marble version has a frame mat gold finished, shelves made of Havana-colored glass and Rosa Egeo marble. The wooden version has glass shelves in Havana and ash elm wood, metal frame bronze shadow mat. It is available in two size: Socrate 35 model and Socrate 130 model.

L35

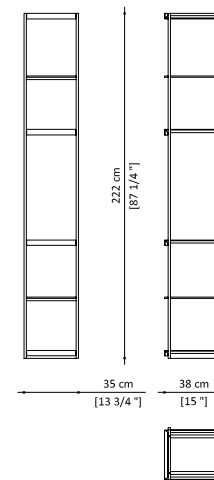

WOOD | LIB.SOCR.521

Ash elm wood and glass shelves - Transparent glass shelves col. Avana
Metal frame bronze shadow mat finish

MARBLE | LIB.SOCR.520

Rosa egeo marble and glass shelves
Metal frame mat gold finish

L130

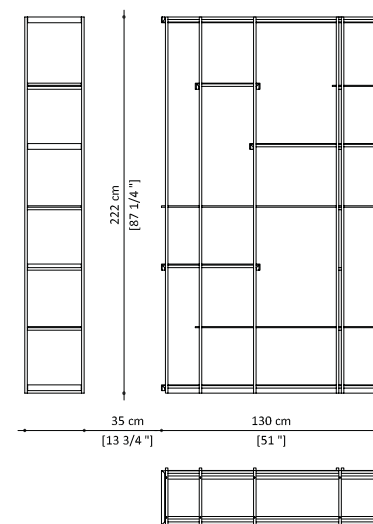

WOOD | LIB.SOCR.511

Ash elm wood and glass shelves - Transparent glass shelves col. Avana
Metal frame bronze shadow mat finish

MARBLE | LIB.SOCR.510

Rosa egeo marble and glass shelves
Metal frame mat gold finish

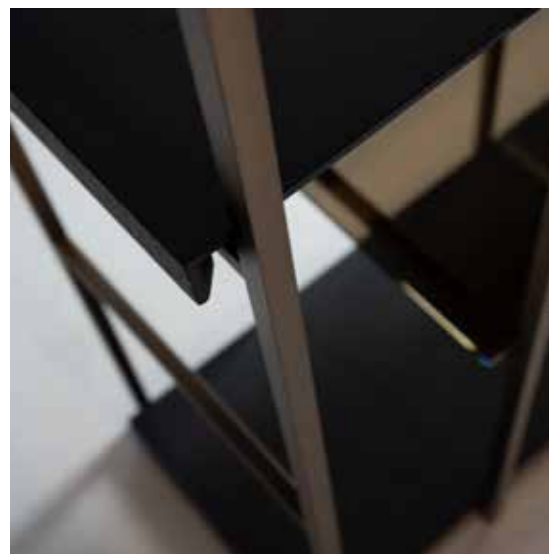

◀ Ripiani polimerici dalle linee grafiche e leggere.

Multi material shelves designed by light graphic lines.

Inspiration



SOCRATE LOW

DESIGN | PAOLO CASTELLI

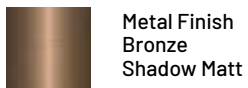

Metal Finish
Bronze
Shadow Matt



Wood
Elm Grey



**Transparent
glass col. Avana**

La ricerca dei materiali rende Socrate Low un interessante oggetto di design che arreda lo spazio con un'eleganza discreta. Socrate Low è realizzato con struttura metallica composta da tubolari a sezione quadrata, finitura bronze shadow opaco. Il top è realizzato in olmo cenere mentre il piano sottostante in vetro color Avana.

The research of its materials makes Socrate Low an essential object of design, which furnishes the space with a discreet elegance. Socrate Low is made of a square section tubular metal structure, finished in finishing mat bronze shadow. The top shelf is made of ash-coloured elm, while the mid shelf is made of transparent glass col. Havana.

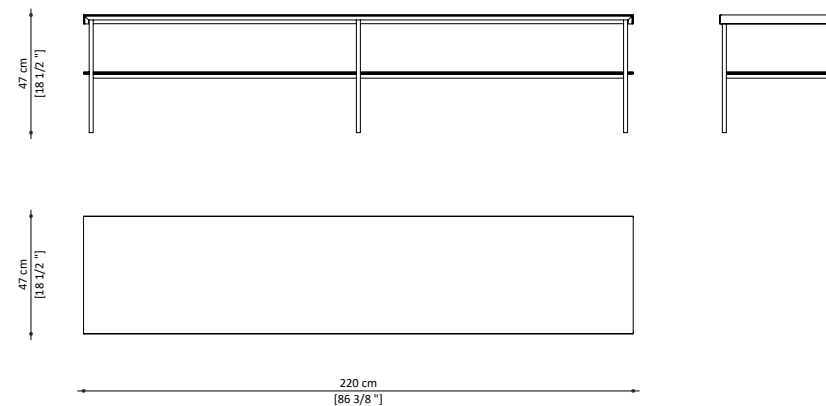

GLASS | LIB.SOCR.121

Two glass shelves - Transparent glass shelves col. Avana
Metal frame bronze shadow mat finish

WOOD & GLASS | LIB.SOCR.120

Ash elm wood and glass shelves - Transparent glass shelves col. Avana
Metal frame bronze shadow mat finish



Inspiration

BDS BOOKSHELF

DESIGN | BORROMEODESILVA



Metal Finish
Matt Gold



Wood
Black Ashwood

Bds Bookshelf è una raffinata libreria a giorno, dalle geometrie decise e razionali, che bene si sposa con il concetto dell'home office o di un ufficio direzionale. La libreria è composta da montanti intrecciati tra loro in metallo con finitura oro opaco a sezione quadrata, che si incrociano a 45 gradi, formando un particolare disegno a croce. I ripiani e lo zoccolo sono rivestiti in essenza frassino black. Infine, la libreria si correda di 3 cassetti in legno, con la medesima finitura.

Bds Bookshelf is an elegant open bookshelf, boasting bold and rational lines, that will complement both home offices and elegant corporate spaces.

The structure comprises twisting elements made in square-section metal with a matt gold finish, which intersect at 45 degrees forming a cross pattern. Shelves and wooden base are covered with black ash veneer. The bookshelf features 3 wood drawers with the same finish.

C

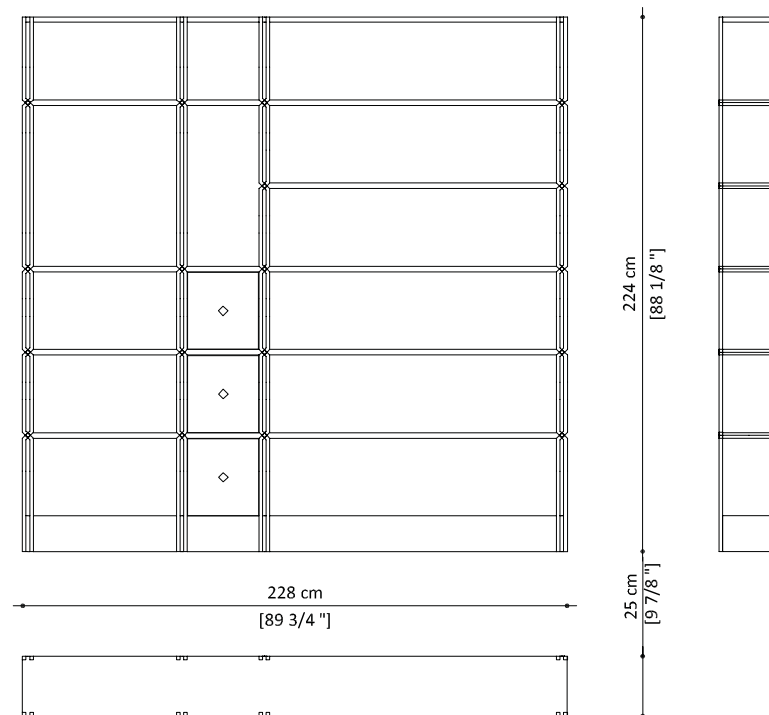

BDS BOOKSHELF | LIB.BDSB.500

Black ash wood
Metal frame mat gold finish



C

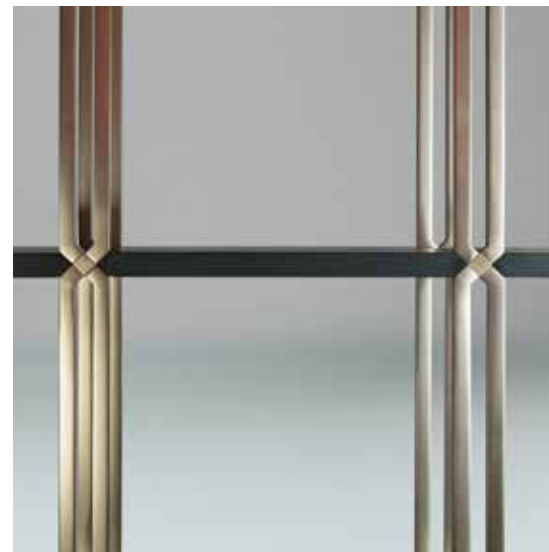
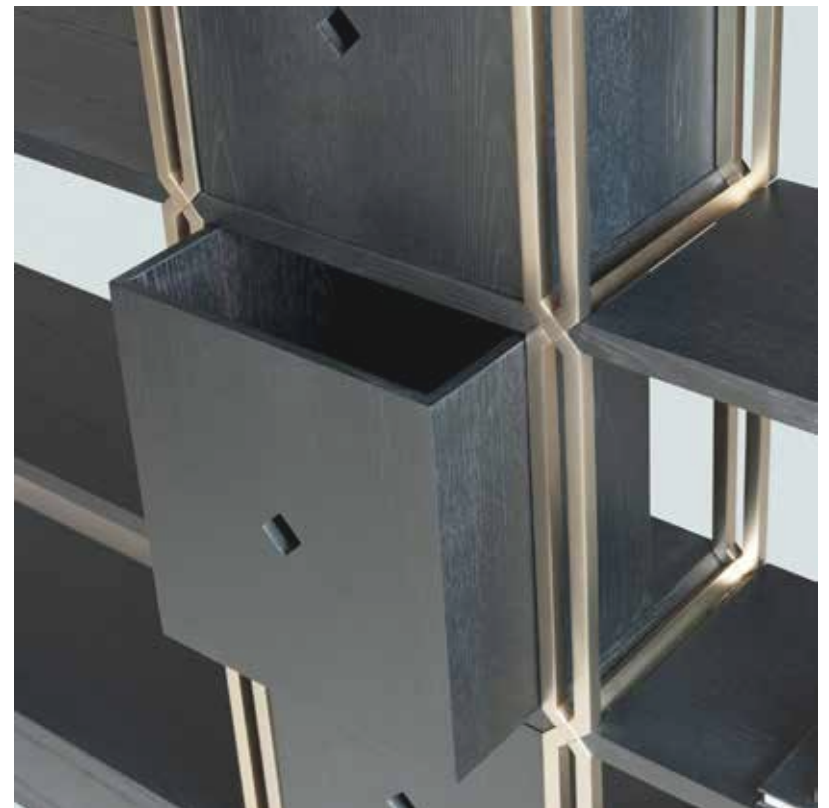

◀ I montanti si incrociano a 45 gradi e formano un particolare disegno a croce.

The metal bars intersect at 45° creating a unique cross design.

Inspiration

C

FOR LIVING SHOWCASE

DESIGN | PAOLO CASTELLI



Metal Finish
Matt Bronzed
Brass



Satinated brass



**Extraclear
glass**

Un esclusivo armadio rivisto in chiave artistica, dalle preziose rifiniture che richiamano un'orientalità d'antan. La struttura e le due maniglie sono in ottone satinato con vernice trasparente protettiva, il basamento è in metallo finitura bronzo ottone opaco, mentre il vetro è extrachiaro temperato.

Di particolare pregio la versione con LED, con top realizzato con un pannello illuminante a LED che esalta e sottolinea le forme e gli oggetti all'interno.

An exclusive case reviewed in an artistic vision thanks to its precious finishing evoking an ancient Eastern touch.

The structure and two jewels handles are in satinated brass with transparent protective varnish, basement is finished in mat bronzed brass, the glass is extraclear tempered. The precious upper cover is made of a LED light panel that glorifies the shapes and the objects featured in it.

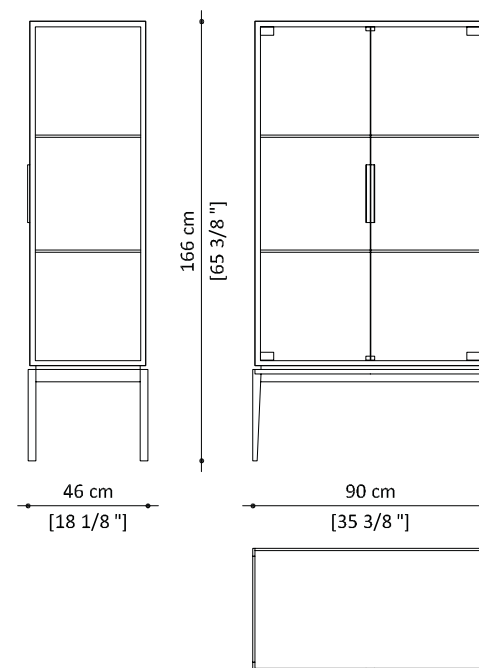

FOR LIVING SHOWCASE | LIB.FORL.600
Metal brass, extraclear glass

FOR LIVING SHOWCASE LED | LIB.FORL.610
Metal brass, extraclear glass
Led lighting system



◀ **Vetrinetta espositiva con luce led integrata.**

Showcase with integrated illumination.

Inspiration



SOFT RATIO HIGH & LOW CABINET

DESIGN | PAOLO CASTELLI

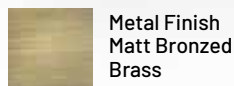

**Metal Finish
Matt Bronzed
Brass**



**Metal Black
Matt varnished**



**Backlaquered
Glass Col. Oasi
(Low model)**



**Natural
Leather
Col. 634 Oasi**

Cabinets con base in metallo finitura nero opaco con doppi piedini in metallo finitura bronzo ottone opaco. Sono disponibili con struttura in legno laccata opaca o rivestita in pelle (ante e fronte) con un pattern geometrico che richiama la struttura. L'interno è laccato in tinta.

Il modello basso è attrezzato con 1 ripiano in vetro extrachiaro, mentre il fondo è in vetro specchiato col. bronzo lucido. Top in vetro retrolaccato lucido in tinta. Apertura touch delle ante con sistema push-pull.

Il modello High è disponibile nella versione con 3 ripiani in vetro extrachiaro o nella versione con 2 cassetti imbottiti rivestiti internamente in microfibra in tinta e 1 ripiano in vetro extrachiaro, ed è dotato di illuminazione interna a LED, fondo in vetro specchiato col. bronzo.

Cabinets with metal base matt black finish with double metal feet matt bronzed brass finish. Models are available with wooden structure matt-laquered or leather covered (doors and front) with geometric pattern resembling the structure. Low cabinet is fitted inside with one extra-clear transparent glass shelf, while the back is made of mirrored bronze glass. Top made in glass backlaquered (same colour). The doors are opened with a push-pull touch system. High model is available inside with 3 shelves in extra clear glass or with 1 shelf in extra clear glass and 2 drawers with internal upholstery covered in microfiber, same colour. LED lighting, and back in mirrored bronze glass.

LOW

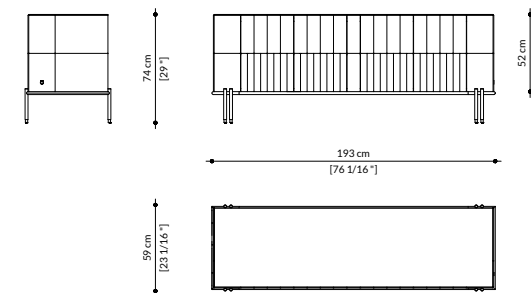

LACQUERED | LIB.SOFT.121

Metal base matt black finish with double metal feet matt bronzed brass finish
Top in back-lacquered glass. Mat laquered

LEATHER | LIB.SOFT.120

Metal base matt black finish with double metal feet matt bronzed brass finish
Top in back-lacquered glass. Doors and sides covered in leather

HIGH

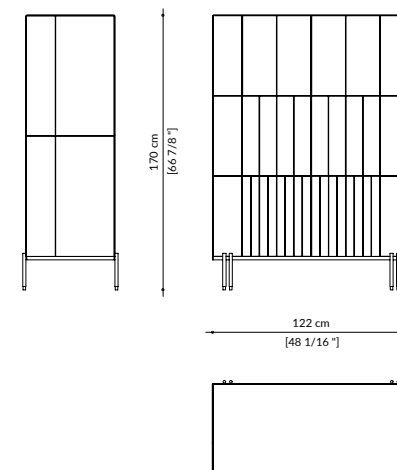

LACQUERED SHELVES | LIB.SOFT.111

Metal base matt black finish with double metal feet matt bronzed brass finish
Top in back-lacquered glass. Mat laquered. 3 Shelves in extra clear glass

LACQUERED DRAWERS | LIB.SOFT.110

Metal base matt black finish with double metal feet matt bronzed brass finish
Top in back-lacquered glass. Mat laquered. 1 Shelf in extra clear glass and 2 drawers.

LEATHER SHELVES | LIB.SOFT.113

Metal base matt black finish with double metal feet matt bronzed brass finish
Top in back-lacquered glass. Doors and sides covered in leather
3 Shelves in extra clear glass

LEATHER DRAWERS | LIB.SOFT.112

Metal base matt black finish with double metal feet matt bronzed brass finish
Top in back-lacquered glass. Doors and sides covered in leather
1 Shelf in extra clear glass and 2 drawers



Inspiration

C

FINE COLLECTION

180B

DESIGN | PAOLO CASTELLI



Metal Finish
Matt Gold



Wood
Ebony
Macassar



Bovine Leather
Col. 602
Dark Brown

Fine Collection Cabinet 180 B è un mobile contenitore basso dalle linee pulite, realizzato con una combinazione di diversi materiali preziosi che creano una proposta estetica unica, adatto ad arredare eleganti ambienti living e dining.

Il mobile è realizzato in finitura ebano macassar, con 4 ante esternamente rivestite in pelle bovina color testa di moro e bordatura laccata lucida marrone scuro Ral 8019 - 100 gloss. Le maniglie sono realizzate in metallo con finitura oro opaco spazzolato a mano. L'interno, sempre in ebano macassar è dotato di un ripiano in vetro extrachiaro temperato mentre le ante sono laccate color marrone lucido 100 gloss. Infine, i piedini, anch'essi in ebano macassar, presentano un elegante inserto in metallo con finitura oro opaco.

Fine Collection Cabinet 180 B is a low cabinet with clean, regular lines, made using a combination of different precious materials, a unique piece that will complement all elegant living or dining spaces. The cabinet is made of fine macassar ebony finish, with 4 doors entirely covered with dark brown leather with a dark brown 100 gloss lacquered finish (Ral 8019) around the edges. The metal handles have a matt gold finish, brushed by hand. The inside is also macassar ebony and features a tempered extra-clear glass shelf, while the doors have a dark brown 100 gloss lacquered finish. The legs, also macassar ebony, have a metal insert with matt gold finish.

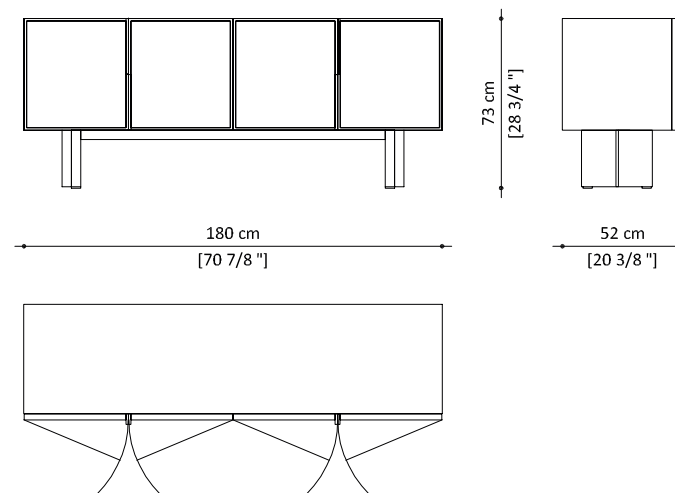

180B | LIB.FINE.120

Makassar frame - mat gold feet and handles
Brown lacquered details 100 gloss Ral 8019
Doors covered in dark brown leather col. 602



C



Inspiration



FINE COLLECTION

220

DESIGN | PAOLO CASTELLI



Metal Finish
Matt Gold



Wood
Ebony
Macassar



Bovine Leather
Col. 602
Dark Brown

Il Fine Collection Cabinet 220 è un mobile contenitore basso a giorno con ribalta laterale, ha una linea pulita ed elegante, ed è realizzato con una combinazione di diversi materiali preziosi, ideale per arredare eleganti ambienti living. Il mobile è realizzato in finitura ebano macassar e l'anta a ribalta è esternamente rivestita in pelle bovina color testa di moro con bordatura laccata lucida marrone scuro Ral 8019 - 100 gloss. La maniglia è in metallo con finitura oro opaco spazzolato a mano. All'interno, l'anta a ribalta è laccata lucida marrone scuro 100 gloss e piedi in ebano hanno un inserto in metallo con finitura oro opaco.

Fine Collection Cabinet 220 is an open-fronted low cabinet with lateral flap door, boasting clean elegant lines, made with a combination of different precious materials, ideal in all elegant living spaces. The cabinet is made of fine macassar ebony finish; the flap door is entirely covered with dark brown leather on the front, with a dark brown 100 gloss lacquered finish around the edges (Ral 8019). The metal handle has a matt gold finish, brushed by hand. Inside, the flap door is dark brown with a 100 gloss lacquered finish and ebony legs with a metal insert with a matt gold finish.

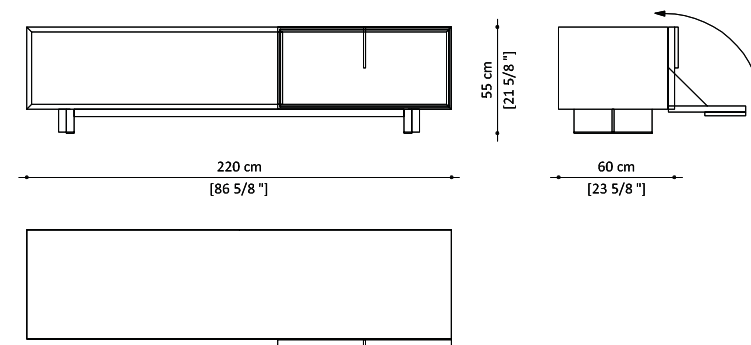

220 | LIB.FINE.110

Makassar frame - mat gold feets and handles
Brown lacquered details 100 gloss Ral 8019
Flap door covered in dark brown leather col. 602



BLACK & GOLD CABINET

DESIGN | LUCA SCACCHETTI



Metal Finish
Matt Flamed
Brass



Laquering
Black
100 gloss

HIGH - Realizzato in mdf laccato lucido nero 100 gloss e poggia su una base in metallo con finitura in ottone fiammato opaco come le maniglie che completano il disegno del mobile stesso. L'interno in mdf è laccato nero opaco, ed è composto da 2 ripiani e 3 cassetti. Luce led interna.

LOW - Realizzato in mdf laccato lucido nero 100gloss e poggia su una base in metallo pieno con finitura ottone fiammato opaco come le preziose maniglie che arricchiscono il disegno del mobile stesso. L'interno è laccato nero opaco ed è dotato di un ripiano in mdf, con le 4 ante con bordo a 45°.

Entrambe le versioni sono disponibili in col. avorio Ral 1035.

HIGH - Cabinet made from mdf, black with a 100 gloss lacquered finish, and has a metal base in matt flamed brass finishing, as have the handles that complete the cabinet's design. The inside, which is mdf lacquered matt black, black on the doors, features two shelves and three drawers. Led light inside.

LOW - The cabinet is made from mdf, with a black 100 gloss lacquered finish and a metal base finished matt flamed brass, the same as the handles that add aesthetic value to the cabinet's design. The matt black lacquered inside features a mdf shelf, and has 4 doors with a 45° angle edge.

Both models are available with white top lacquered 100 gloss ral. 1035.

HIGH

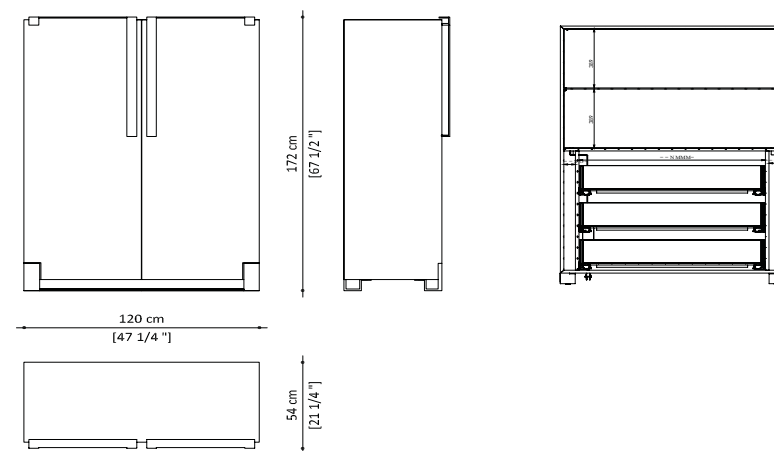

HIGH | LIB.BLAC.110
MDF lacquered 100 gloss
Col. Black Ral 9005 or Ivory Ral 1035

LOW

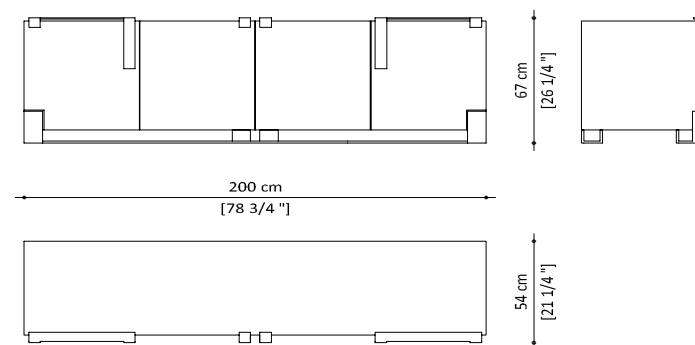

LOW | LIB.BLAC.120
MDF lacquered 100 gloss
Col. Black Ral 9005 or Ivory Ral 1035

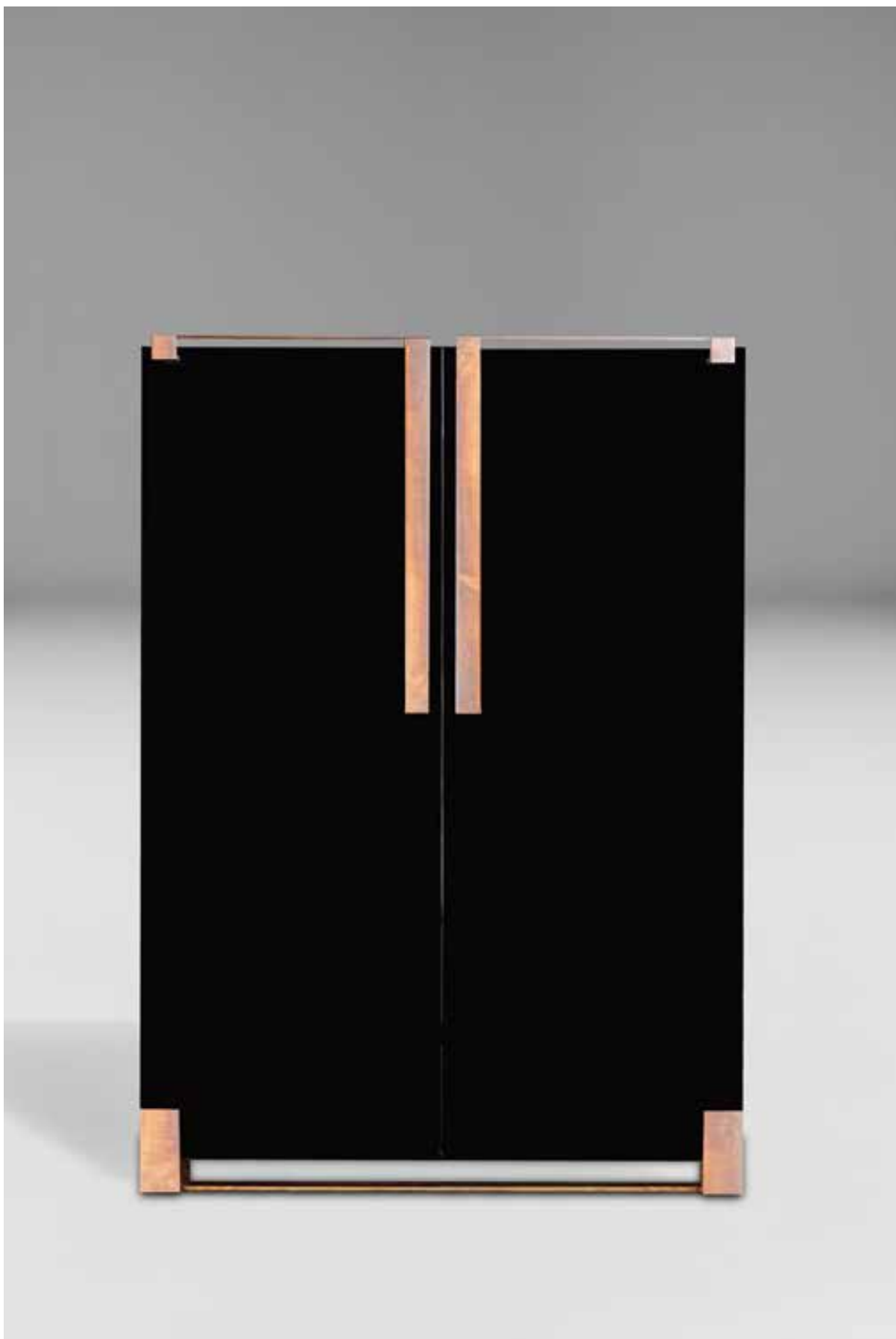

◀ Galvanica: prezioso processo di trattamento dell'ottone in grado di conferire allo stesso un'inaspettata tridimensionalità.

Galvanic process: galvanic bath which gives to brass precious three-dimensional effect.

Inspiration



DROMO CABINET

DESIGN | VITTORIO PARADISO



Metal Finish
Matt Gold



Saffiano
Laquering
Bronze



Matt
Brass



Wood
Dark Oak

Ha una struttura in rovere massello impreziosita da elementi esagonali in ottone naturale satinato. Il contenitore è realizzato in MDF con laccatura lucida 100 gloss impreziosita da una sfumatura radiale in tinta arricchito da un pattern in saffiano, color bronzo, così come le ante. L'interno, illuminato a luce led, è laccato opaco marrone Ral 8019 con schienale in vetro satinato col. bronzo. Il cabinet è attrezzato con un ripiano in mdf laccato opaco, due cassetti imbottiti rivestiti internamente in microfibra, e un ripiano ulteriore in vetro extrachiaro. Il cabinet basso è predisposto con 4 ante. Apertura push pull.

It has a solid oak structure embellished with hexagonal elements in natural satin brass. The container is made of MDF with 100 gloss lacquer embellished with a radial shade in the same shade enriched with a pattern in saffiano, bronze color, as well as the doors. The interior, lit with LED light, is Ral 8019 matt brown lacquered, with back in bronze mirrored glass mat. The cabinet is equipped with a mat lacquered mdf shelf, 2 drawers with internal upholstery covered in microfiber, and a further shelf in extra-clear glass. Low cabinet has 4 doors. Push pull opening system.

HIGH

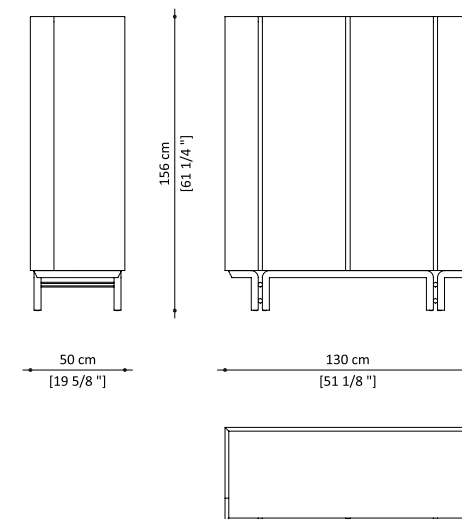

HIGH | LIB.DROM.112

Structure lacquered Saffiano Finish Bronze
Base made in dark oak wood - Brass matt details

LOW

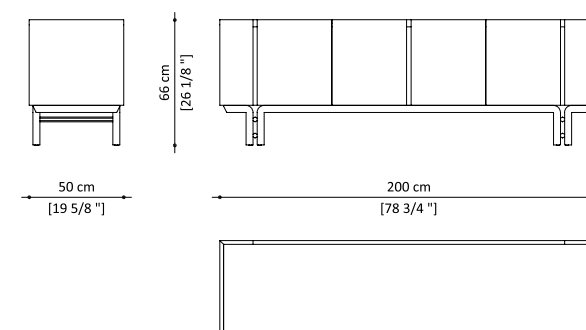

LOW | LIB.DROM.122

Structure lacquered Saffiano Finish Bronze
Base made in dark oak wood - Brass matt details



◀ **Pattern Saffiano: decorazione artigianale che riprende le più esclusive lavorazioni tipiche dalle conerie del distretto Toscano.**

Saffiano pattern: handcrafted tanning typical of Tuscan district.

FOR LIVING LOW CABINET

DESIGN | PAOLO CASTELLI



Alternative colour options

	Metal Finish Matt Gold		Laquering Matt Gold		Laquering Black 100 gloss		Laquering Grey Brown 100 gloss		Laquering Brown 100 gloss
Peacock model									
	Metal Finish Bronze Shadow Mat		Satin glass Peacock		Laquering Grey Brown 100 gloss	Optional Ceramic handles		Ceramic Handles	

La struttura è realizzata in mdf verniciato lucido 100 gloss oppure oro opaco, con due ante che si muovono a scorrimento con parziale sovrapposizione. Le maniglie e la base sono realizzate in metallo con finitura oro opaco.

La versione Peacock prevede struttura verniciata 100 gloss in colore Grigio Marrone Ncs 5010 Y50r, ante in vetro satinato con disegno "Pavone", maniglie e base in metallo finitura Bronze shadow.

Su richiesta disponibili su entrambi i modelli maniglie in preziosa ceramica artigianale faentina.

The structure is mdf with a 100 gloss lacquered or matt gold finish and has two partially overlapping sliding doors. The handles and the base are made in metal with mat gold finish.

The Peacock version has lacquered structure col. Grey Brown Ncs 5010 Y50r, satin glass doors with a "Pavone" design, handles and structure are made in metal - finish bronze shadow.

On both models as optional precious artisan Faentine ceramic handles.

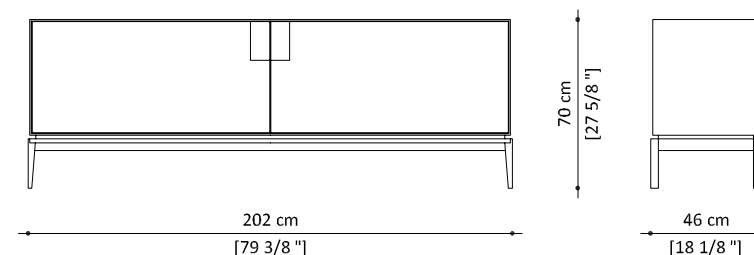

LAQUERED | LIB.FORL.120

Metal base and handles mat gold finish
Lacquered 100 Gloss in colours: Mat gold, Black Ral 9005,
Brown grey Ncs 5010 Y50r, Brown Ral 8019

PEACOCK | LIB.FORL.120P

Metal base and handles in matt bronze shadow finish
Lacquered 100 gloss ncs 5010 Y30R Satined glass front doors

CERAMIC HANDLES (OPTIONAL)



CE



◀ **Su richiesta maniglie decorate con ceramica artigianale faentina.**

On request available with handcrafted handles in Faenza ceramic.

FOR LIVING HIGH CABINET

DESIGN | PAOLO CASTELLI



 Metal Finish Matt Gold	 Laquering Grey Brown 100 gloss	 Bovine Leather Col. 638 Light Grey	Alternative colour options	 Laquering Brown 100 gloss	
Peacock model	 Metal Finish Bronze Shadow Mat	 Satin glass Peacock	 Laquering Grey Brown 100 gloss	Optional Ceramic handles	 Ceramic Handles

La struttura in mdf è laccata lucida 100 gloss, mentre la base in metallo è trattata con finitura oro opaco come le due maniglie. Le ante esternamente sono rivestite in pelle bovina pieno fiore in tinta e rifinite con una cornice laccata lucida 100 gloss. L'interno si presenta laccato opaco in tinta, con schiena rivestita in vetro specchiato satinato col. bronzo e organizzato con opportuni 4 ripiani in cristallo extrachiaro oppure 3 cassetti, 1 ripiano verniciato lucido 100 gloss e 1 ripiano in cristallo. Luce led interna. La versione Peacock prevede ante in vetro satinato con disegno "Pavone", maniglie e struttura in metallo finitura Bronze shadow, o su richiesta in ceramica finitura "Bronze shadow".

The mdf high cabinet, with a 100 gloss lacquered finish, has a metal base with a matt gold finish, the same as its two handles. The outside of the doors is covered in fine leather of the same colour and finished with a frame with a 100 gloss lacquered finish. Inside it is lacquered matt in the same colour, with the back covered in bronze mirrored glass mat with 4 extracrystal shelves, or with 3 drawers, 1 shelf painted 100 gloss, and 1 crystal shelf. Led internal light. The Peacock version includes satin glass doors with a "Pavone" design, handles and tructure made in metal - finish bronze shadow or in ceramic "Bronze shadow" finish (optional).

HIGH SHELVES

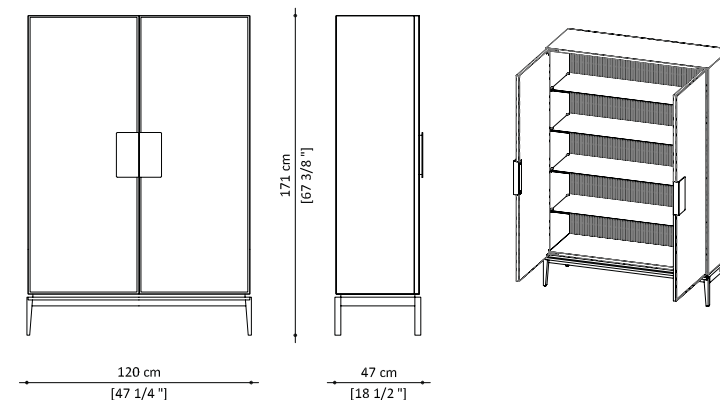

LEATHER | LIB.FORL.110

Metal base and handles mat gold finish
Lacquered 100 Gloss in colours: Brown grey Ncs 5010 Y50r , Brown Ral 8019
Doors covered in leather

PEACOCK | LIB.FORL.110P

Metal base and handles in matt bronze shadow finish
Lacquered 100 gloss ncs 5010 Y30R Satined glass front doors

HIGH SHELVES & DRAWERS

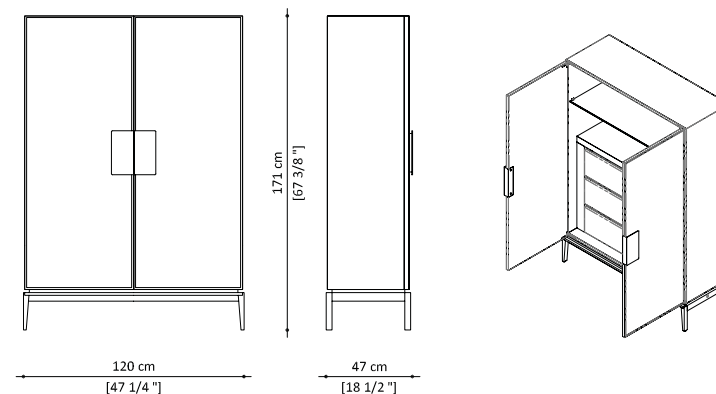

LEATHER | LIB.FORL.111

Metal base and handles mat gold finish
Lacquered 100 Gloss in colours: Brown grey Ncs 5010 Y50r , Brown Ral 8019
Doors covered in leather

PEACOCK | LIB.FORL.111P

Metal base and handles in matt bronze shadow finish
Lacquered 100 gloss ncs 5010 Y30R Satined glass front doors

CERAMIC HANDLES (OPTIONAL)



◀ Ante in vetro satinato con disegno "Pavone"

Satin glass doors with a "Pavone" design

FOR LIVING TALL CABINET

DESIGN | PAOLO CASTELLI



Metal Finish
Matt Gold



Laquering
Grey Brown
100 Gloss

Optional
Ceramic Handles
Riflessi



Alternative colour options



Laquering
Black
100 gloss



Laquering
Brown
100 gloss

Ispirato ai mobili bar degli anni '50, questo mobile arreda con classe leganti zone giorno. La struttura è realizzata in mdf laccato lucido 100 gloss, mentre la base in metallo è realizzata con finitura oro opaco. Le maniglie sono realizzate in metallo con finitura oro opaco oppure su richiesta ceramica artigianale faentina a riflessi con effetto cangiante. L'interno si presenta laccato opaco in tinta con schiena rivestita in vetro specchiato satinato col. bronzo e organizzato con due ripiani in cristallo extrachiario temperato.

Inspired by the bar cabinets of the 1950s, this item brings style to elegant living spaces. The mdf structure has a 100 gloss lacquered finish and a metal base with matt gold finish. The handles, are made in metal with matt gold finish or artisanal ceramic from Faenza, with iridescent effect. Inside it is lacquered matt in the same color, with the back covered in bronze mirrored glass mat. featuring two extraclear crystal shelves.

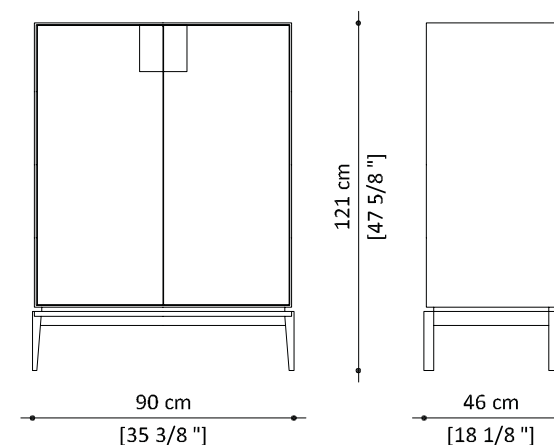

TALL | LIB.FORL.130

MDF Lacquered 100 gloss with metal handles mat gold finish
Available colours: Black Ral 9005, Grey Brown Ncs 5010 Y50r, Brown Ral 8019

CERAMIC HANDLES (OPTIONAL)

FOR LIVING COCKTAIL

DESIGN | PAOLO CASTELLI



Metal Finish
Matt Gold



Laquering
Brown
100 gloss



Leather
Galuchat
effect

Peacock
model
(doors)



Satin glass
Peacock

For Living Cocktail Cabinet è allestito internamente con 2 ripiani in cristallo extrachiaro, spessore 8mm e due cassetti con fronte rivestito in pelle effetto galuchat ed interno in morbida microfibra. Base in metallo con ripiano finitura oro opaco, vano contenitore accato lucido 100 gloss colore marrone RAL 8019 internamente ed esternamente. Le ante sono attrezzate con 6 alloggiamenti in ottone e rivestite esternamente in pelle effetto galuchat, mentre il fondo è in vetro specchiato satinato col. bronzo. All'interno è presente un'illuminazione LED a spegnimento automatico con la chiusura della ante. La versione speciale Peacock prevede ante in vetro satinato con disegno "Pavone". Portata massima per ciascuna ante: 5 kg.

For Living Cocktail Cabinet contains extra clear lead 2 glass crystal shelves 8mm thick and two drawers covered in fine bovine leather printed with galuchat texture, upholstered inside with smooth microfiber. It features a mat gold finish base holding a cabinet made of 100 gloss lacquered mdf color brown RAL 8019, both inside and outside. The shutters are upholstered in fine bovine leather printed with galuchat texture, with 6 inner containers made in brass, while the back is available in bronze mirrored glass mat. Led internal light. The Peacock special edition includes satin glass doors with a "Pavone" design. Maximum load for each door: 5 kg.

COCKTAIL

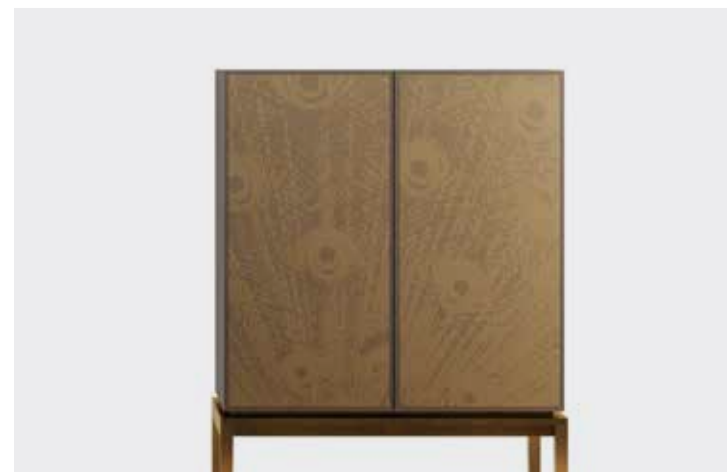
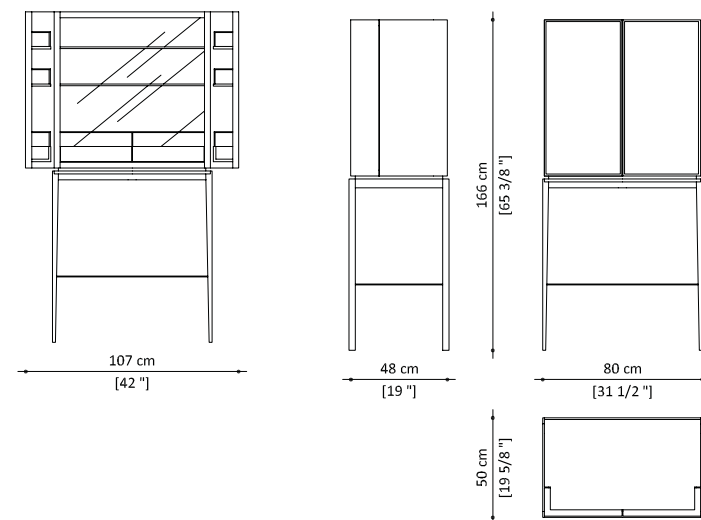

LACQUERED | LIB.FORL.710

Metal base mat gold finish
Lacquered 100 Gloss Brown Ral 8019 - Doors covered in leather with galuchat texture

PEACOCK | LIB.FORL.710P

Metal base mat gold finish
Lacquered 100 Gloss Brown Ral 8019 - Doors covered in satinated glass front doors

Inspiration



FOR LIVING FRIDGE

DESIGN | PAOLO CASTELLI



For Living Fridge Cabinet è un refrigeratore dotato di un ripiano in cristallo extrachiaro spessore 8 mm, e ospita all'interno vani per accessori e cristalleria da cocktail. La base in metallo con ripiano è rifinita con preziosa lavorazione oro opaco e sostiene il vano contenitore in mdf-laccato lucido 100 gloss colore marrone RAL 8019 internamente ed esternamente. Le ante sono rivestite in pelle bovina stampata effetto galuchat, mentre il fondo è disponibile in vetro specchiato satinato col. bronzo. All'interno è presente un'illuminazione LED a spegnimento automatico con la chiusura della ante. Disponibile la versione Peacock che prevede ante in vetro satinato con disegno "Pavone". Portata massima per ciascuna ante: 5 kg.

For Living Fridge Cabinet is an absolute refrigerator with a lead glass crystal shelf 8mm thick, in order to host accessories and cocktail crystal ware. It features a mat gold finish base holding a cabinet made of 100 gloss lacquered mdf color brown RAL 8019, both inside and outside. Doors are covered in bovine leather printed with galuchat texture; while the inside is available in bronze mirrored glass mat. Led internal light. The Peacock version includes satin glass doors with a "Pavone" design. Maximum load for each door: 5 kg.

FRIDGE

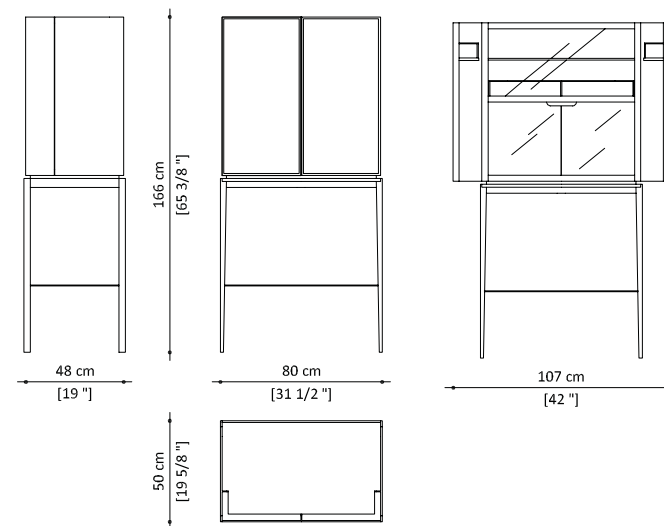

LACQUERED | LIB.FORL.720

Metal base mat gold finish
Lacquered 100 Gloss Brown Ral 8019 - Doors covered in leather with galuchat texture

PEACOCK | LIB.FORL.720P

Metal base mat gold finish
Lacquered 100 Gloss Brown Ral 8019 - Doors covered in satin glass front doors
Inner fridge doors covered in bronze mirrored glass mat



C



Inspiration

C

FINE COLLECTION

180A

DESIGN | PAOLO CASTELLI



Metal Finish
Matt Gold



Laquering
Grey Brown
100 Gloss



Bovine
Leather
Col. 638
Light Grey

Alternative colour options



Laquering
Ivory
100 gloss



Bovine
Leather
Col. 633
Vanilla

Fine Collection Cabinet 180 A è un elegante cassettono, ideale per ambienti notte e guardaroba. Il mobile è realizzato in mdf laccato lucido 100 gloss con 6 cassetti, il cui fronte è rivestito in pelle bovina in tinta e con bordi laccati lucidi. Le maniglie sono in metallo con preziosa finitura oro opaco satinato. L'interno dei cassetti è in mdf laccato opaco e con fondo leggermente imbottito e rivestito in elegante microfibra col. taupe. I piedi sono sempre in mdf laccato lucido 100 gloss con elegante inserto in metallo che riprende la pregiata lavorazione delle maniglie.

Elegant chest of drawers, ideal in any bedroom or wardrobe area. Made in mdf 100 gloss lacquered finish, it features 6 drawers, frontally covered in leather same colour, with glossy lacquered edges. The metal handles have a matt gold finish. The drawers, matt lacquered mdf inside, have a lightly padded bottom, covered with elegant microfibre col. taupe. The legs are also MDF 100 gloss lacquered finish and have metal inserts recalling the finish of the handles.

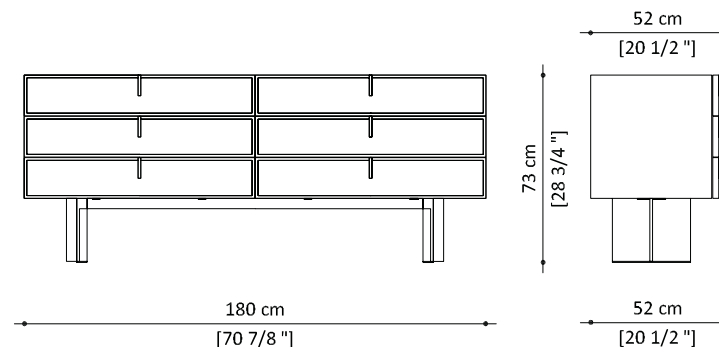

180A | LIB.FINE.130

Mat gold details and handles
Lacquered 100 gloss. Available colours: Ivory Ral 1013, Grey Brown Ncs 5010 Y50r
Drawers front covering in leather (same colour)
Inner covering in microfiber (same colour)



C



FINE COLLECTION CHEST OF DRAWERS

DESIGN | PAOLO CASTELLI



Alternative colour options



Metal Finish
Matt Gold



Laquering
Ivory
100 gloss



Bovine
Leather
Col. 633
Vanilla



Laquering
Grey Brown



Bovine
Leather
Col. 638
Light Grey

CHEST OF DRAWERS 3 - Il mobile è realizzato in mdf laccato lucido 100 gloss con 3 cassetti, il cui fronte è rivestito in pelle bovina in tinta e con bordi laccati lucidi. Le maniglie sono in metallo con preziosa finitura oro opaco satinato. L'interno dei cassetti è in mdf laccato opaco e con fondo leggermente imbottito e rivestito in elegante microfibra in tinta col. taupe. I piedi sono sempre in mdf laccato lucido 100 gloss con elegante inserto in metallo finitura oro opaco.

CHEST OF DRAWERS 7 - Il mobile è realizzato in mdf laccato lucido 100 gloss con 7 cassetti, il cui fronte è rivestito in pelle bovina in tinta e con bordi laccati. Le maniglie sono in metallo con preziosa finitura oro opaco satinato. L'interno dei cassetti è in mdf laccato opaco e con fondo leggermente imbottito e rivestito in elegante microfibra in tinta col. taupe. Zoccolo in laminato metallico color oro.

CHEST OF DRAWERS 3 - Made in mdf with a 100 gloss lacquered finish, it features 3 drawers, frontally covered leather of the same colour, with glossy lacquered edges. The metal handles have a galvanic matt gold finish. The drawers, matt lacquered mdf inside, have a lightly padded bottom, covered with elegant microfiber col. taupe. The legs are also with a 100 gloss lacquered finish and have metal inserts in mat gold finish.

CHEST OF DRAWERS 7 - Made in mdf, with a 100 gloss lacquered finish, it features 7 drawers, frontally covered leather of the same colour, with glossy ivory lacquered edges. The metal handles have a matt gold finish. The drawers, matt lacquered mdf inside, have a lightly padded bottom, covered with elegant microfiber col. taupe. Its laminated metal base is colored gold.

3 DRAWERS

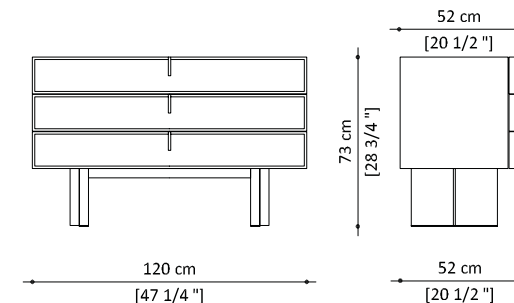

3 DRAWERS | LIB.FINE.410

Mat gold details and handles

Lacquered 100 gloss. Available colours: Ivory Ral 1013, Grey Brown Ncs 5010 Y50r

Drawers front covering in leather (same colour)

Inner covering in microfiber (same colour)

7 DRAWERS

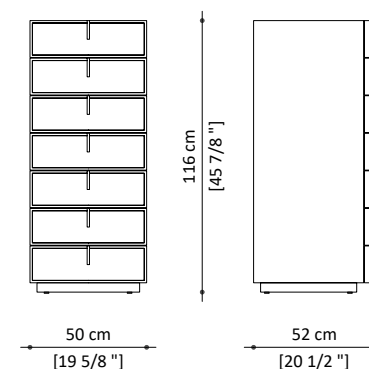

7 DRAWERS | LIB.FINE.420

Mat gold details and handles

Lacquered 100 gloss. Available colours: Ivory Ral 1013, Grey Brown Ncs 5010 Y50r

Drawers front covering in leather (same colour)

Inner covering in microfiber (same colour)



C



FINE COLLECTION BEDSIDE TABLE

DESIGN | PAOLO CASTELLI



Alternative colour options



Metal Finish
Matt Gold



Laquering
Grey Brown
100 gloss



Bovine
Leather
Col. 638
Light Grey



Laquering
Ivory
100 gloss



Bovine
Leather
Col. 633
Vanilla

Comodino dalla linea elegante e pulita. Il mobile è realizzato in mdf laccato lucido 100 gloss con 2 o 3 cassetti, il cui fronte è rivestito in pelle bovina in tinta e con bordi laccati lucidi. Le maniglie sono in metallo con preziosa finitura oro opaco satinato. L'interno dei cassetti è in mdf laccato opaco e con fondo leggermente imbottito e rivestito in elegante microfibra col. taupe. Zoccolo in laminato metallico color oro.

Bedside table boasting elegant, clean lines. Made in mdf with a 100 gloss lacquered finish, it features 2 or 3 drawers, frontally covered with leather of the same colour, with glossy lacquered edges. The metal handles have a matt gold finish. The drawers, matt lacquered mdf inside, have a lightly padded bottom, covered with elegant microfiber col. taupe. Its laminated metal base is golden.

2 DRAWERS

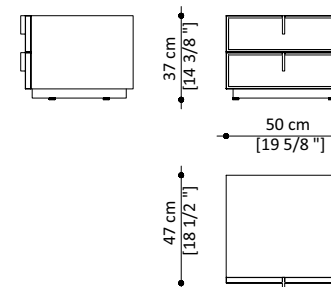

2 DRAWERS | LIB.FINE.210

Mat gold details and handles
Lacquered 100 gloss. Available colours: Ivory Ral 1013, Grey Brown Ncs 5010 Y50r
Drawers front covering in leather (same colour)
Inner covering in microfiber (same colour)

3 DRAWERS

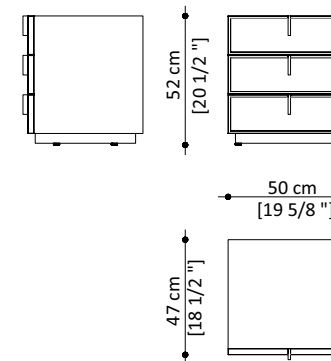

3 DRAWERS | LIB.FINE.220

Mat gold details and handles
Lacquered 100 gloss. Available colours: Ivory Ral 1013, Grey Brown Ncs 5010 Y50r
Drawers front covering in leather (same colour)
Inner covering in microfiber (same colour)



C



TUM CABINETS

DESIGN | PAOLO CASTELLI



Wood
Dark Oak



Leather cords
Col. Natural



Metal Finish
Bronze
Shadow Mat

Serie di contenitori notte dai carattere fortemente maschile, con un animo elegante e raffinato. Sono realizzati con una struttura in legno, disponibile in finitura laccato opaco oppure rovere tinto scuro. Le gambe sono realizzate in tubolare di legno in finitura coordinata alla struttura.

Le ante sono rivestite in metallo, sempre in finitura bronze shadow opaco, con applicazione di cordini in cuoio naturale che decorano tutto il frontale.

Set of night storage units with a strongly masculine character, showing an elegant and refined soul. They are made with a wooden structure, available in matt lacquered finish or dark stained oak. The legs are made of tubular wood in a finish coordinated with the structure.

The doors are covered in metal, equally in an opaque bronze shadow finish, with the application of natural leather cords that decorate the entire front.

LOW

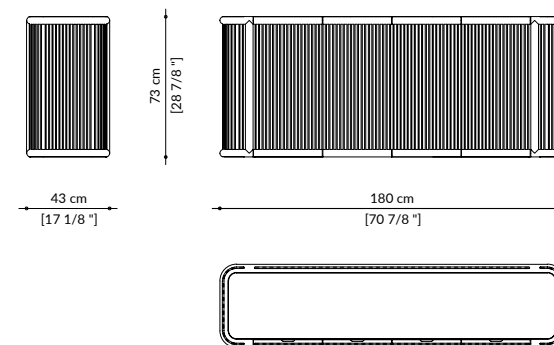

WOOD | LIB.TUMC.120

Wooden frame and legs- Available finishes: lacquered 100 gloss, dark oak
Doors bronze shadow matt finished - Decoration with leather cords col. natural

HIGH

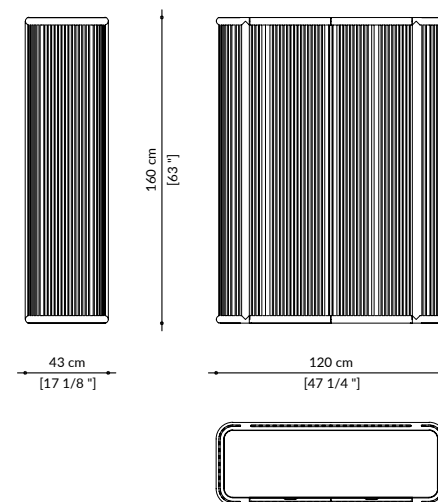

WOOD | LIB.TUMC.110

Wooden frame and legs- Available finishes: lacquered 100 gloss, dark oak
Doors bronze shadow matt finished - Decoration with leather cords col. natural

Inspiration



TUM BEDSIDE TABLE

DESIGN | PAOLO CASTELLI



Wood
Dark Oak



Leather cords
Col. Natural

Serie di contenitori notte dal carattere fortemente maschile, con un animo elegante e raffinato. Il comodino a giorno è realizzato con base e top rotondi in legno (rovere tinto scuro), montanti sempre in legno con finitura coordinata alla base. Il comodino con cassetto aggiunge un vano con fronte coordinato alla struttura, apertura push-pull. La struttura è decorata con cordini di cuoio naturale.

Set of night storage units with a strongly masculine character, showing an elegant and refined soul. The open nightstand is made with a round wooden base and top (dark stained oak), supports are made in wood with a coordinated finish at the base. The closed model has one drawer with wooden front, coordinated with the structure, that opens with push-pull system. Natural leather cords decorate the structure.

OPEN

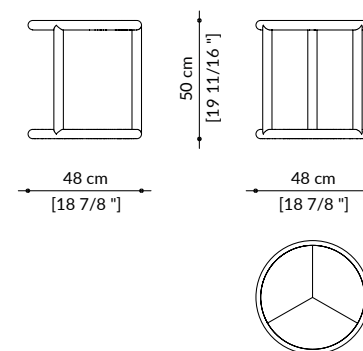

WOOD | LIB.TUMB.210

Wooden frame and legs - dark oak

1 DRAWERS

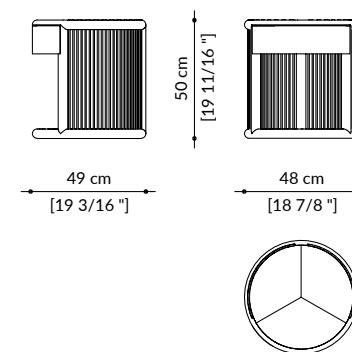

WOOD | LIB.TUMB.220

Wooden frame and legs - dark oak
Leather cords col. Natural

DEA NIGHT STORAGE

DESIGN | VITTORIO PARADISO



Wood
Eucalyptus



Bronze
Mirrored Glass Mat



Bovine Leather
Col. 638 Light Grey

Il sistema di contenitori notte Dea ha forme morbide, plasmate dall'armoniosa alternanza di linee convesse, del fronte e del retro, e concave, dei fianchi. I contenitori sono realizzati con una particolarissima essenza di eucalipto frisè: la superficie del legno è increspata naturalmente per l'azione nel tempo delle raffiche di vento sugli alberi. Il top è in specchio bronzo satinato mentre i fianchi sono rivestiti in pregiati pellami con bordatura di chiusura (sopra e sotto) in metallo oro satinato opaco.

The Dea night storage system has soft shapes, formed by the harmonious alternation of lines that are convex on the front and the back, and concave on the sides. The containers are made with a very special essence of eucalyptus frisè: the surface of the wood is naturally rippled by the action of the gusts of wind on the trees over time. The top is in satin finish bronze mirror while the sides are covered in fine leathers with closing edge banding (above and below) in matt satin gold metal.

BEDSIDE TABLE 3 DRAWERS

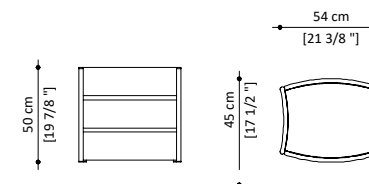

EUCALYPTUS || LIB.DEAC.223

Eucalyptus frisè wood structure
Bronze mirrored top satin finished
Sides covered with bovine leather

CHEST OF DRAWERS 3

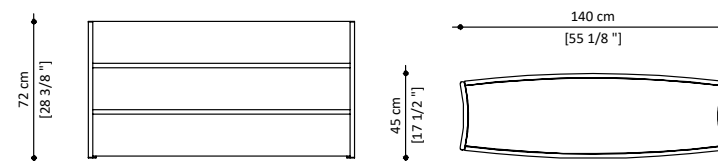

EUCALYPTUS | LIB.DEAC.410

Eucalyptus frisè wood structure
Bronze mirrored top satin finished
Sides covered with bovine leather

CHEST OF DRAWERS 7

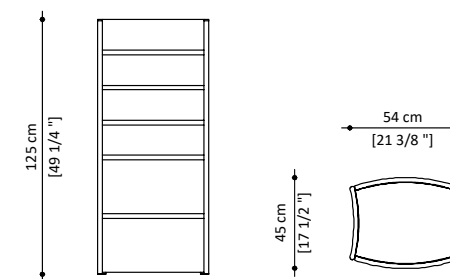

EUCALYPTUS | | LIB.DEAC.420

Eucalyptus frisè wood structure
Bronze mirrored top satin finished
Sides covered with bovine leather



”
Legno di eucalipto: essenza dalle suggestive venature grigiastre di varie gradazioni.

Eucalyptus wood: wood with grey scaled veining.
”

Inspiration
THE HOUSE OF ELEGANCE



PAOLO CASTELLI

LETTI BEDS

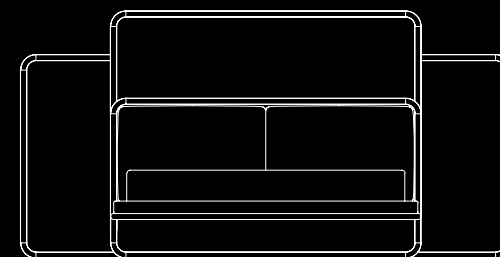
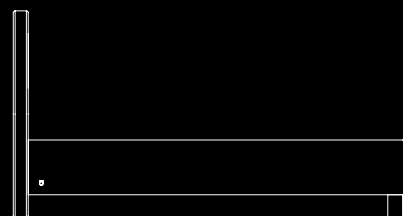
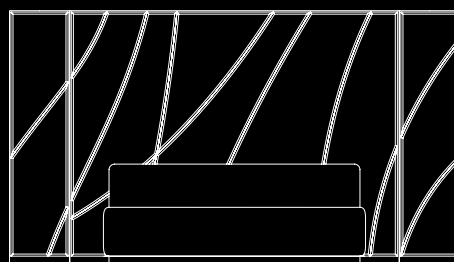
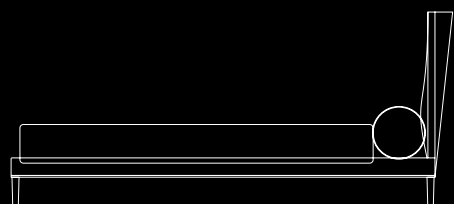

Inspiration



TUM BED

DESIGN | PAOLO CASTELLI



Lacquered
Col. Red
Ral 3000



Nabuck
Col. 06 Light Grey

Struttura letto dalle forme leggere e ariose, e dalla forte componente decorativa Tum Bed ha una struttura in tubolare di legno, disponibile in finitura rovere tinto scuro o laccato opaco. La testata è composta da due cuscini imbottiti in piuma d'oca, rivestimento disponibile in pregiati tessuti o pelli a campionario. Dimensioni materasso: 180 x 200 cm
Rete e materasso non inclusi.

Bed frame with light and airy shapes, and with a strong decorative component, Tum Bed has a tubular wooden structure, available in dark stained oak or matt lacquered finish. The headboard is composed of two eiderdown padded cushions, upholstery available in fine fabrics or leathers in the samples page.
Mattress dimensions: 180 x 200 cm
Bed slat and mattress not included.

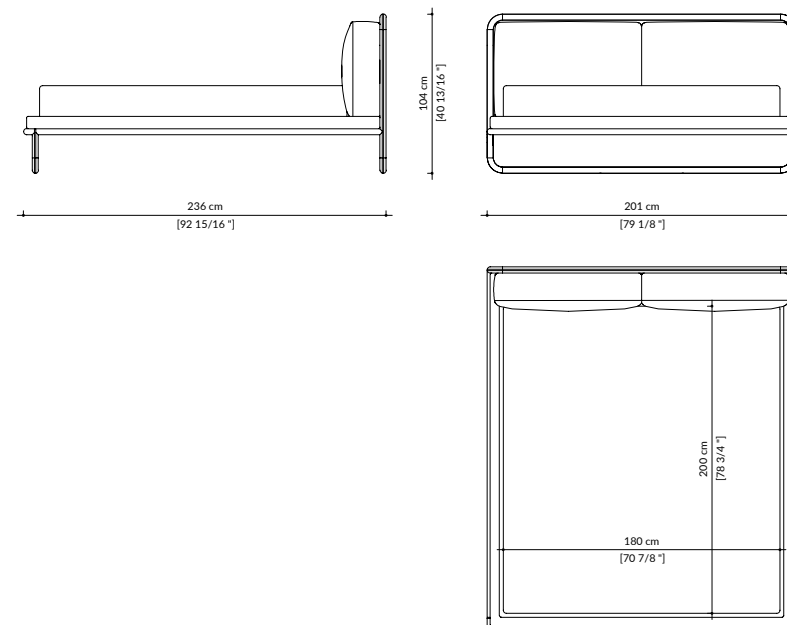

FABRIC SUPERIOR | NOT.TUMB.110.SUP

Wooden frame- Available finishes: lacquered matt Col. Red Ral 3000, Ivory Ral 1013
Fabric Superior

FABRIC DELUXE | NOT.TUMB.110.DEL

Wooden frame- Available finishes: lacquered matt Col. Red Ral 3000, Ivory Ral 1013
Fabric Deluxe

LEATHER | NOT.TUMB.110.PEL

Wooden frame- Available finishes: lacquered matt Col. Red Ral 3000, Ivory Ral 1013
Leather

NABUK | NOT.TUMB.NAB

Wooden frame- Available finishes: lacquered matt Col. Red Ral 3000, Ivory Ral 1013
Nabuck

Inspiration



TUM AMET BED

DESIGN | PAOLO CASTELLI



Lacquered
Col. Ivory



Nabuck
Col. 06 Light Grey



Decorative
Fabric

Il modello Tum Amet aggiunge alla struttura letto Tum un elegante sistema di paraventi scorrevoli, che ampliano la testata e consentono di creare un divertente gioco di quinte. Il sistema di paraventi è composto di tre elementi con struttura in tubolare di legno, disponibile in finitura rovere tinto scuro o laccato opaco, rivestiti in tessuti decorativi con fantasie sfiziose e colorate. Il pannello centrale è fisso, mentre i due laterali sono scorrevoli e si innestano su un binario a terra, garantendo giochi di sovrapposizioni e trasparenze. Dimensioni materasso: 180 x 200 cm Rete e materasso non inclusi.

The Tum Amet model adds to the Tum bed frame an elegant sliding screen system, which widens the headboard and allows you to create a fun game of wings. The screen system is made up of three elements with a tubular wooden structure, available in a dark stained or matt lacquered oak finish, covered in decorative fabrics with fanciful and colourful patterns. The central panel is fixed, while the two sides are sliding and engage on a track on the ground, ensuring games of overlapping and transparency. Mattress dimensions: 180 x 200 cm Bed slat and mattress not included.

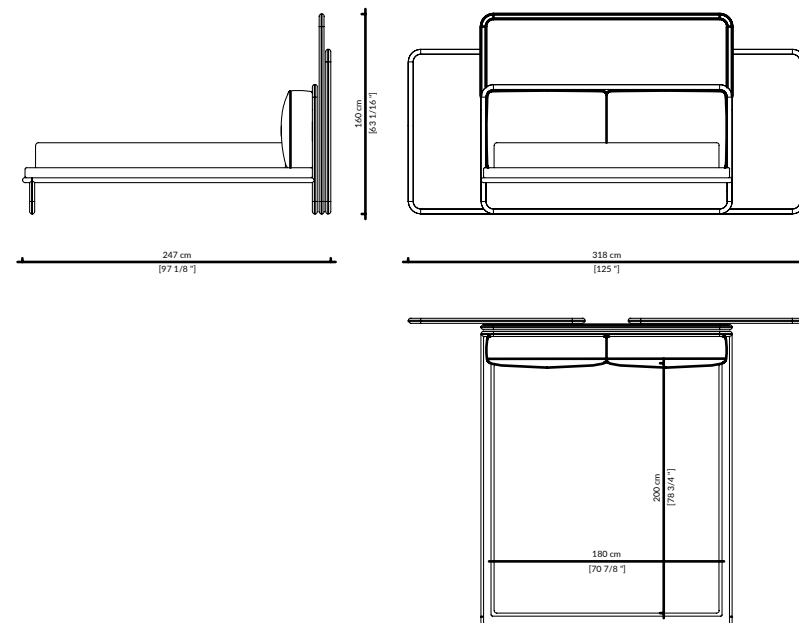

BED WITH SCREEN | NOT.TUMB.120.NAB

Wooden frame- Available finishes: lacquered matt Col. Red Ral 3000, Ivory Ral 1013
Nabuck headboard
Panel covered with special decorative fabrics



Inspiration



STRIPES BED

DESIGN | PAOLO CASTELLI



Metal Finish
Matt Gold



Fabric
Velvet Mana
Col. 0477 Grey

Grande linearità ed equilibrio dei volumi per il letto Stripes. Testata imbottita e rivestita in tessuto a fasce verticali di diverse dimensioni, bordatura perimetrale in tinta oppure su richiesta in metallo finitura oro satinato. Il giroletto è sostenuto da piedini in tubolare ellittico con finitura oro satinato opaco. Per il suo carattere neutro ma sofisticato, Stripes può essere inserito sia in ambienti di impronta minimale che in spazi maggiormente connotati sotto il profilo decorativo.
Rete e materasso non inclusi. Dimensione materasso 180 x 200 cm.

The Stripes bed projects great linearity and balance of volumes. Its padded headboard is upholstered in fabric with vertical bands of different sizes and features a coordinated fabric edging, or alternative metallic perimeter edging in satin finish gold (optional). The bed frame is supported by elliptical tubular feet with a matt satin gold finish. Due to its neutral but sophisticated character, Stripes is equally at home in both minimalist environments and more ornately decorated rooms. Mattress and bedspring not included - Mattress Size: 180x200 cm.

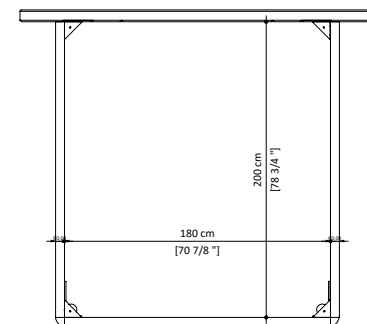
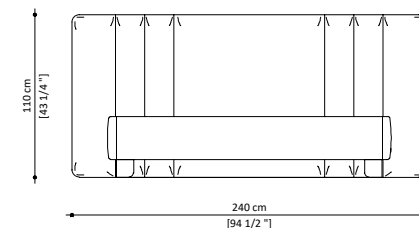
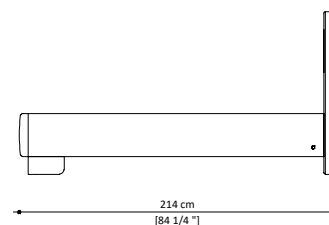

STRIPES WITHOUT METAL | NOT.STRI.110.ECO

Satin gold finished feet
Eco-Friendly Leather

STRIPES WITHOUT METAL | NOT.STRI.110.SUP

Satin gold finished feet
Fabric Sateen

STRIPES WITHOUT METAL | NOT.STRI.110.PEL

Satin gold finished feet
Leather

STRIPES WITHOUT METAL | NOT.STRI.110.NAB

Satin gold finished feet
NabukNabuk

STRIPES | NOT.STRI.100.ECO

Satin gold finished perimeter edging
Eco-Friendly Leather

STRIPES | NOT.STRI.100.SUP

Satin gold finished perimeter edging
Fabric Sateen

STRIPES | NOT.STRI.100.PEL

Satin gold finished perimeter edging
Leather

STRIPES | NOT.STRI.100.NAB

Satin gold finished perimeter edging
Nabuk



Inspiration



ODISSEA HIGH METAL

DESIGN | VITTORIO PARADISO



Metal Finish
Matt Gold



Laquering
Grey Brown



Bovine Leather
Col. 638 Light Grey

La testata (con pannelli laterali mobili) è interamente rivestita in tessuto raso e risulta essere particolarmente morbida grazie all'imbottitura, che le conferisce un aspetto accogliente e confortevole. Gli inserti metallici con finitura oro accendono di riflessi ambrati i nostri sogni. Grazie alla sofisticata scelta cromatica Odissea Bed può essere inserito sia in ambienti di impronta minimale che in spazi maggiormente decorativi. Dimensioni materasso: 180 x 200 cm. Rete e materasso non inclusi.

The bedhead -composed with movable side panels-, wholly covered in satin fabric, is particularly soft due to an upholstery that lends it a welcoming and comfortable aspect. The metal inserts with golden finish light up our dreams with amber reflections. Thanks to a sophisticated chromatic choice, Odissea Bed is suited to both minimalist environments and more highly decorative spaces. Mattress and bedspring not included - Mattress Size: 180x200 cm.

H 181

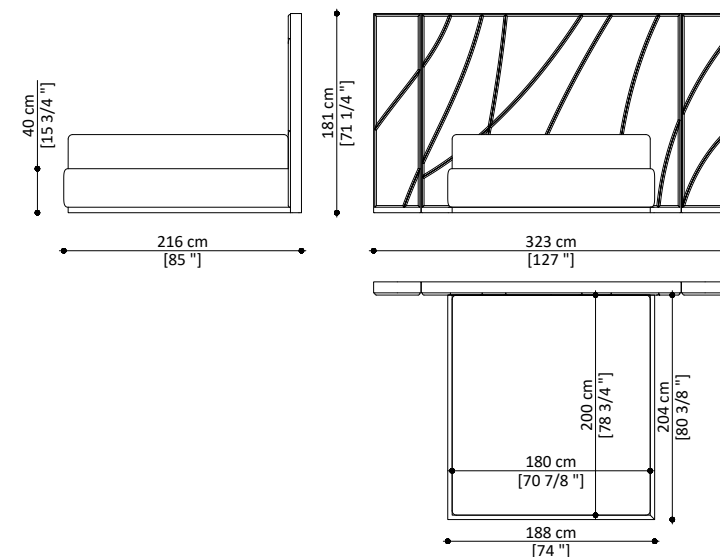

METAL SATEEN FABRIC | NOT.ODIS.100.SUP

Metal Frame mat gold finish - Movable side panels
Fabric Sateen

METAL LEATHER | NOT.ODIS.100.PEL

Metal Frame mat gold finish - Movable side panels
Bovine Leather

METAL NABUCK | NOT.ODIS.100.NAB

Metal Frame mat gold finish - Movable side panels
Nabuk

Inspiration



ODISSEA LOW WOOD

DESIGN | PAOLO CASTELLI



Wood varnished
Matt Gold



Laquering
Grey Brown



Bovine Leather
Col. 638 Light Grey

La testata fissa e interamente rivestita in tessuto raso risulta essere particolarmente morbida grazie all'imbottitura, che le conferisce un aspetto accogliente e confortevole. Gli inserti in legno con finitura oro accendono di riflessi ambrati i nostri sogni. Grazie alla sofisticata scelta cromatica Odissea Bed può essere inserito sia in ambienti di impronta minimale che in spazi maggiormente decorativi. Dimensioni materasso: 180 x 200 cm . Rete e materasso non inclusi.

The fixed bedhead, wholly covered in satin fabric, is particularly soft due to an upholstery that lends it a welcoming and comfortable aspect. The wooden inserts with golden finish light up our dreams with amber reflections. Thanks to a sophisticated chromatic choice, Odissea Bed is suited to both minimalist environments and more highly decorative spaces. Mattress and bedspring not included - Mattress Size: 180x200 cm.

H 140

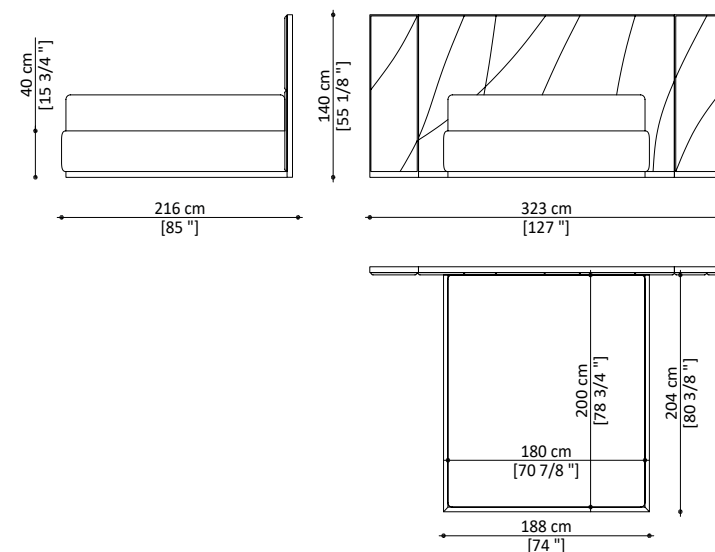

WOOD ECOLEATHER | NOT.ODIS.110.ECO

Wooden fixed frame mat gold finish - Fixed headboard
Ecoleather

WOOD SATEEN FABRIC | NOT.ODIS.110.SUP

Wooden fixed frame mat gold finish - Fixed headboard
Fabric Sateen

WOOD LEATHER | NOT.ODIS.110.PEL

Wooden fixed frame mat gold finish - Fixed headboard
Leather

WOOD NABUCK | NOT.ODIS.110.NAB

Wooden fixed frame mat gold finish - Fixed headboard
Nabuk





◀ **Testata imbottita, morbida e
accogliente.** ”

“ Soft and comfortable padded
headboard.

Inspiration



GEORGE BED

DESIGN | PAOLO CASTELLI



Metal Finish
Matt Gold



Nabuck
Col. 02 Dark Brown

La struttura è realizzata in legno e rivestita in pregiato nabuk dai toni color cioccolato, con un profilo metallico con finitura oro opaco satinato a decorare tutto il giroletto. I piedini, dalla forma caratteristica, sono rivestiti in nabuk in abbinamento alla struttura. La testata, rivestita in nabuk, è completata da due profili metallici laterali con finitura oro opaco. Nel profilo della testata sono innestate due punti luce da lettura a Led.
Rete e materasso non inclusi. Dimensione materasso 180 x 200

The wooden structure is covered with fine nubuck chocolate-timber tones, with a metallic profile in mat gold finish aimed to decorate the whole base. The feet, with their characteristic shape, are covered in nubuck combined with the structure.
The head covered in nubuck is completed by two side metallic profiles with a precious mat gold finish. In the head profile two LED reading lights are inserted.
Mattress ad support not included. Mattress size 180 x 200

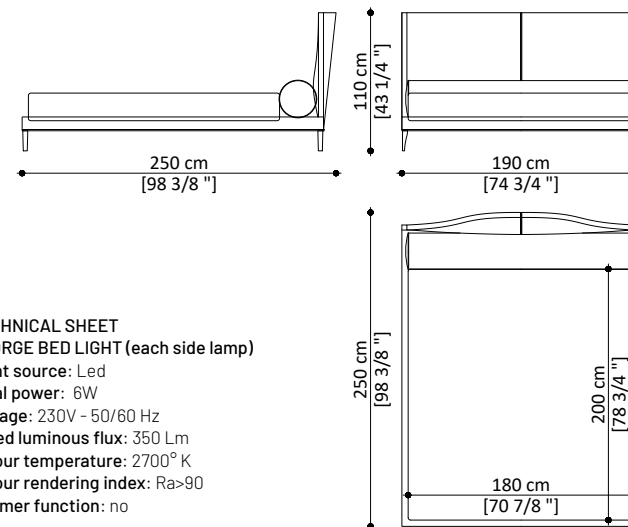

TECHNICAL SHEET
GEORGE BED LIGHT (each side lamp)
Light source: Led
Total power: 6W
Voltage: 230V - 50/60 Hz
Rated luminous flux: 350 Lm
Colour temperature: 2700° K
Colour rendering index: Ra>90
Dimmer function: no



ECOLEATHER | NOT.GEOR.100.ECO

Mat gold frame and details
Eco-Friendly Leather

VELVET SUPERIOR | NOT.GEOR.100.SUP

Mat gold frame and details
Fabric Velvet Superior

LEATHER | NOT.GEOR.100.PEL

Mat gold frame and details
Leather

NABUK | NOT.GEOR.100.NAB

Mat gold frame and details
Nabuk



◀ Testata con punti luce luce integrati.

Headboard with integrated spot lights.

Inspiration



REGENCY BED

DESIGN | PAOLO CASTELLI



Wood Painted
Matt Gold



Fabric
Sateen
Col. Cream

Un letto importante e dalle linee ispirate allo stile Regency inglese dei primi anni del XIX Secolo, adatto a camere padronali ed eleganti suite.

Regency Bed è un letto matrimoniale imbottito caratterizzato da una grande testata in legno finitura oro opaco imbottita con una pregiata lavorazione a disegno spinato, rivestita in eleganti tessuti, pregiate pelli e morbidi nabuk. Il giro letto, che è diviso in due parti, ha una struttura in legno, imbottito e rivestito in coordinato alla testata. Il letto poggia su uno zoccolo in mdf verniciato oro opaco in tinta con la cornice della testata. Disponibili due dimensioni di testata.

Rete e materasso non inclusi. Dimensione materasso 180 x 200 cm.

An elegant bed inspired by the British Regency style of the early 19th Century, ideal for master bedrooms and elegant suites.

Regency Bed is a double bed, defined by a large padded wood mat gold varnished headboard with an elegant and precious spiked design, covered in elegant fabrics, fine leather and soft nubuck.

The wooden structure padded and upholstered in the same material as the headboard. The bed is positioned on a mdf base painted matt gold, coordinated with the headboard frame. The headboard is available in two different sizes.

Mattress ad support not included. Mattress size 180 x 200 cm.

L242

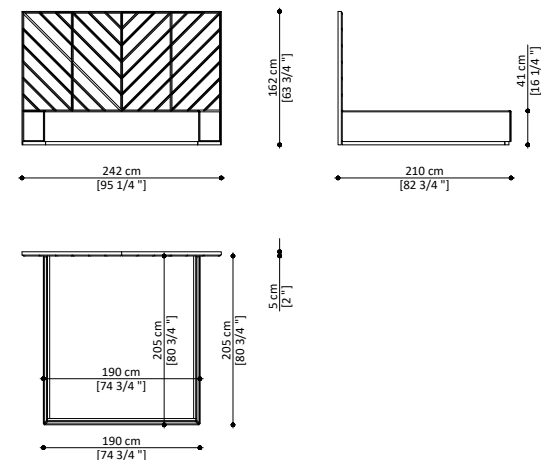

ECOLEATHER | NOT.REGE.110.ECO

Eco-Friendly Leather

SATEEN SUPERIOR | NOT.REGE.110.SUP

Fabric Sateen

LEATHER | NOT.REGE.110.PEL

Leather

NABUK | NOT.REGE.110.NAB

Nabuk

L362

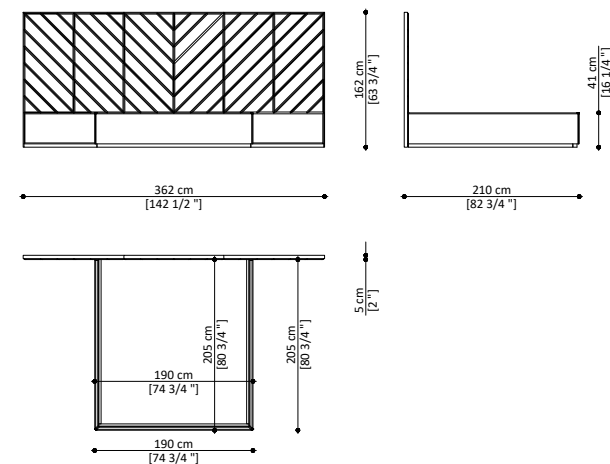

ECOLEATHER | NOT.REGE.120.ECO

Eco-Friendly Leather

SATEEN SUPERIOR | NOT.REGE.120.SUP

Fabric Sateen

LEATHER | NOT.REGE.120.PEL

Leather

NABUK | NOT.REGE.120.NAB

Nabuk



Inspiration
THE HOUSE OF ELEGANCE



PAOLO CASTELLI

COMPLEMENTI COMPLÉMENTS

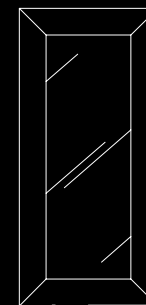
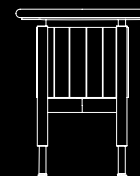
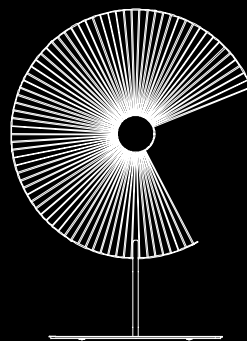
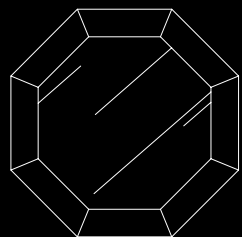
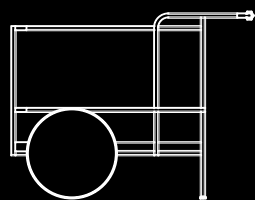

FLARE SCREEN

DESIGN | VITTORIO PARADISO

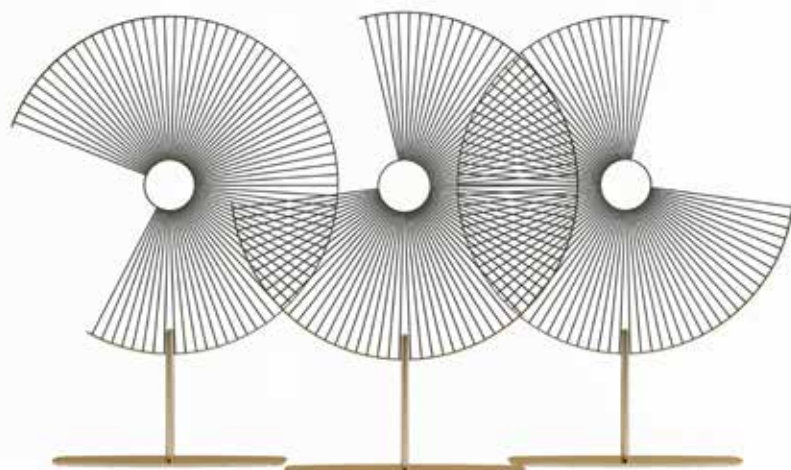

Metal Finish
Matt Gold



Metal Painting
Black

Paravento scultura raffinato ed elegante. Flare è un complemento d'arredo versatile capace di creare divertenti illusioni ottiche. Ha una struttura portante in metallo oro opaco satinato e corpo decorativo centrale con tubi radiali in alluminio brunito. La base è dotata di ruote a sfera per consentire lo spostamento. È possibile modulare l'altezza del paravento e il posizionamento dell'elemento decorativo in 3 inclinazioni diverse. Un oggetto unico di design da riscoprire in tutta la sua delicata bellezza e il suo millenario fascino.

Sophisticated and elegant sculpture screen. Flare is a versatile piece of furniture that can create amazing optical illusions. It has an opaque satinized gold metal load-bearing structure and a decorative central body made of burnished aluminium radial pipes. The base is equipped with ball wheels to allow movement. It is possible to adapt the screen height and put the decorative element in three different inclines. A unique piece of design to be rediscovered in its delicate beauty and everlasting charm.

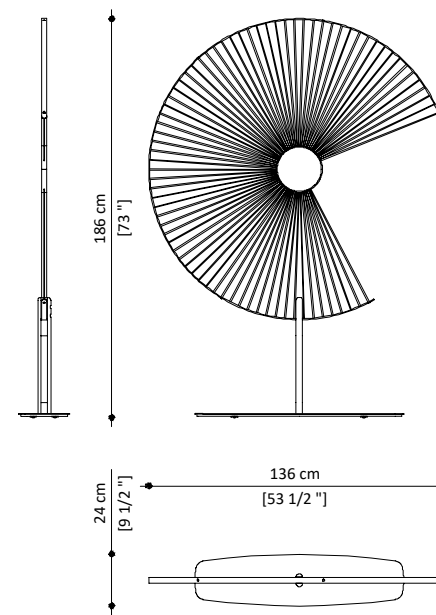

FLARE | COM.FLARE.300
Metal load-bearing structure

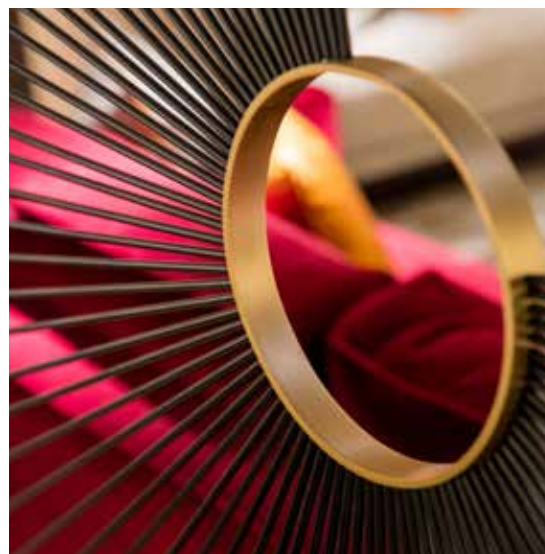

◀ **Inclinazione modulabile del pannello decorativo.**

Adjustable decorative panel.

Inspiration

C

ANODINE SCREEN

DESIGN | PAOLO CASTELLI

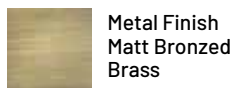
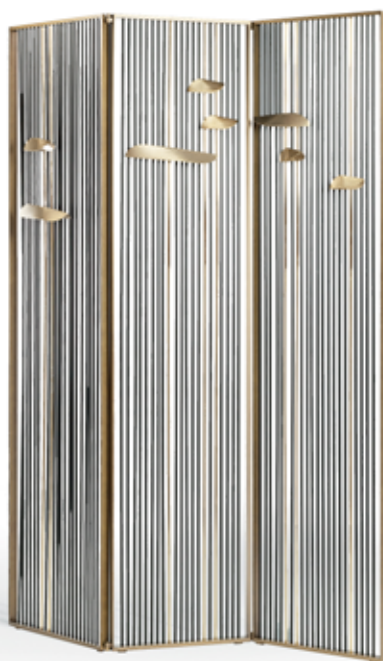

Metal Finish
Matt Bronzed
Brass



Metal Painting
Black Matt



Polished
Brass



Metal Finish
Matt Gold

Scultura/paravento, questo elemento impreziosisce la linea di demarcazione tra gli ambienti del vivere contemporaneo.

Il paravento ha una cornice in metallo finitura bronzo ottone opaco, steli in metallo in finitura nero opaco e in ottone lucido. Nelle aste in ottone sono inseriti elementi decorativi a forma di foglia, realizzati in metallo con finitura oro opaco, realizzati artigianalmente.

Disponibile la versione a 3 o 5 moduli.

Statuesque screen that enriches the frontier among the contemporary living spaces.

The screen has an opaque brass bronze finish metal frame, metal stems black matt finished and polished brass. In the brass temples there are decorative elements in the shape of a leaf, made of metal with a matte gold finish, handcrafted. Available with 3 or 5 modules.

3 PANELS

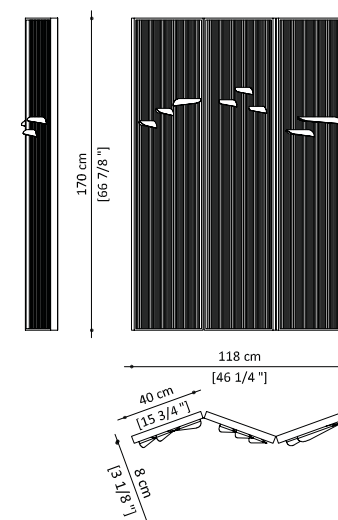

3 PANELS | COM.ANOD.310

Mat gold decorative leaves
Polished brass and black matt stems
Metal frame in mat bronzed brass finish

5 PANELS

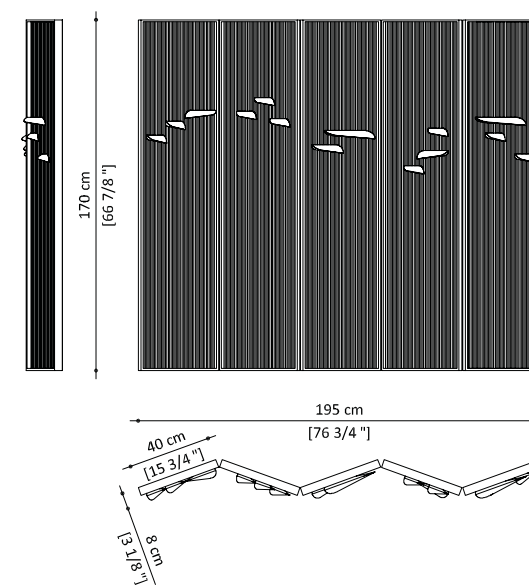

5 PANELS | COM.ANOD.320

Mat gold decorative leaves
Polished brass and black matt stems
Metal frame in mat bronzed brass finish



C



◀ Foglie realizzate
asimmetricamente a mano da
esperti artigiani.

Handcrafted asymmetrical
metal leaves .

Inspiration

C

CONVIVIER TROLLEY

DESIGN | PAOLO CASTELLI



Metal Finish
Bronze
Shadow Mat



Nabuk twisted
Col. 15 Taupe



Transparent
glass col. Avana



Bronze Mirrored
Glass Matt

Carrello utilizzabile come mobile bar e tavolino. La struttura è in metallo con finitura bronze shadow opaco, il ripiano superiore è in vetro trasparente col. avana e quello inferiore è in vetro specchiato satinato col. bronzo. Le ruote sono rivestite in nabuck con pattern ad intrecci, colore 15 taupe, come la maniglia.

Can be used as a mobile bar or side table, or kept in the office at home to add a touch of style to the everyday. The structure is in mat bronze shadow metal, shelf is in transparent glass col. Avana and bronzed satin mirror. Handles and wheels are covered in twisted nabuk col. 15 taupe.

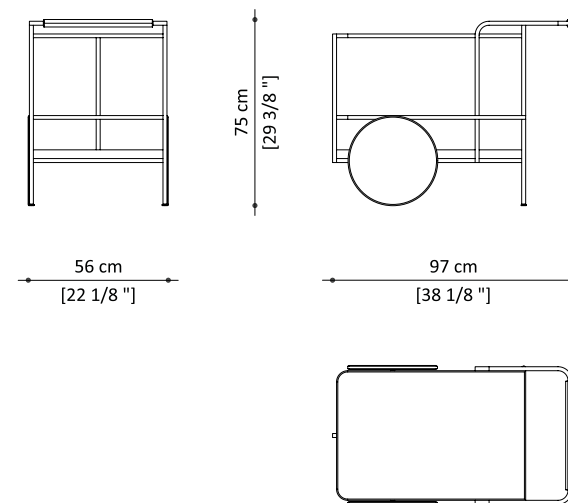

CONVIVIER TROLLEY | COM.TTRO.CON.100

Bronze shadow matt structure
Shelf made in transparent glass col. Avana and bronze mirrored glass matt
Details in twisted nabuk col. 15 taupe.



◀ **Dettagli rivestiti in nabuk con stampa a motivo intrecciato.**

Details covered in nubuck twist effect.

Inspiration

C

MAPUTO CACHE-POT

DESIGN | SAMUELE MAZZA



Natural Stone
Col. White



Natural Stone
Col. Dove



Metal Finish
Bronze
Shadow Matt

La potenza della pietra naturale limestone (colori bianco per i modelli A e B, o grigio tortora per il modello C) esalta il verde del fogliame, in questa serie di vasi dalla struttura metallica impreziosita dalla finitura bronzo shadow opaco.

The power of limestone natural stone (in white color for A and B mode, and dove-grey color for C model) highlights the green of the foliage in this series of metal structure vases enriched with matt shadow bronze finish.

A

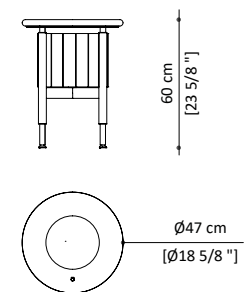

A | COM.VASE.MAP.001

Natural stone vase - Metal frame finished bronze shadow matt
Available colors: white

B

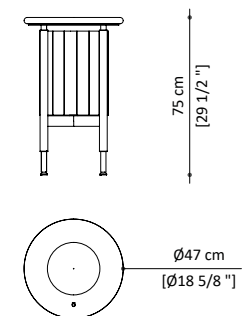

B | COM.VASE.MAP.002

Natural stone vase - Metal frame finished bronze shadow matt
Available colors: white

C

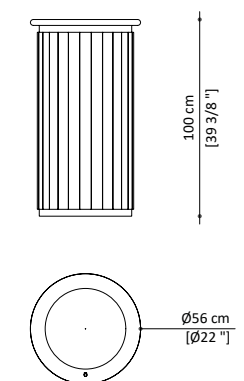

C | COM.VASE.MAP.003

Natural stone vase
Available colors: dove grey



3



ACCRA CACHE-POT

DESIGN | SAMUELE MAZZA

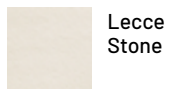

Lecce
Stone



Metal Finish
Bronze
Shadow Matt



Nabuk twisted
Col. 15 Taupe

Imponenti cachepot disponibili in due dimensioni. La struttura in metallo bronzo shadow opaco è rivestita in pelle nabuk con intreccio col. 15 taupe e sorregge il vaso in pietra leccese.

Imposing cachepots available in two sizes. The structure in matt shadow bronze metal is faced with interwoven nubuck cod.15 taupe hide and supports the vase in Lecce stone.

A

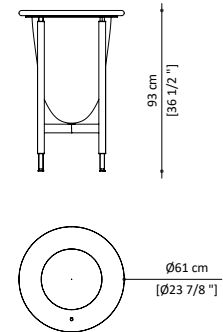

A | COM.VASE.ACC.001
Metal frame bronze shadow matt
Vase in Lecce stone col.beige
Details in twisted nabuk col. 15 taupe

B

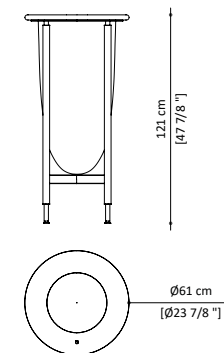

B | COM.VASE.ACC.002
Metal frame bronze shadow matt
Vase in Lecce stone col.beige
Details in twisted nabuk col. 15 taupe.



Inspiration

C

BEST WORLD OCTAGONAL

DESIGN | PAOLO CASTELLI



Metal Finish
Matt Gold

La collezione Best World apre la serie di specchi luminosi di varie forme e dimensioni adatti a molti tipi di ambienti, come eleganti camere padronali, ingressi e diversi ambienti della casa. Best World è composto da un grande specchio di diverse dimensioni con raffinata cornice in metallo arricchita dalla preziosa finitura oro opaco satinato. Ogni pezzo della collezione è dotato, lungo tutto il perimetro, di un moderno sistema illuminante a led che trasforma l'oggetto in una lampada d'atmosfera, riducendo ulteriori fonti luminose nell'ambiente.

È disponibili in tre versioni: Square, Rectangular e Octagonal.

The Best World collection opens the range of luminous mirrors, available in different shapes and dimensions, that can suit a number of different spaces, such as elegant master bedrooms, entrances and other rooms of the house. Best World comprises a large mirror with an exquisite metal frame, boasting an elegant matt gold finish. Each piece of the collection features, along the edge, a modern led lighting system that transforms the mirror into a lamp, creating an atmosphere and reducing other luminous sources in the room.

It is available in three versions: Square, Rectangular and Octagonal.

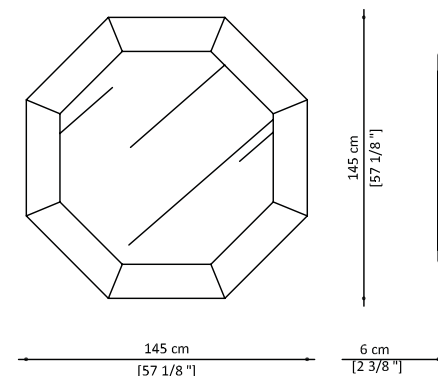

TECHNICAL SHEET

BEST WORLD OCTAGONAL

Light source: Strip Led 12V/24W

Total power: 20W

Voltage: 220 - 240 V

Rated luminous flux: 260 Lm

Colour temperature: 2700° K

Colour rendering index: Ra>80

Dimmer function: no

Cable length: 2 mt

Pin power cable: EU pin

Weight: Kg 80

Package size: 160 x 160 x 40 cm

Package weight: Kg 140

OCTAGONAL | ILL.BEST.530

Mat gold metal frame with led lighting



◀ **Specchi in metallo luminosi
che decorano l'ambiente e
creano atmosfera.**

Metal mirrors with light, which
decorate and enrich the
ambiences.

BEST WORLD RECTANGULAR

DESIGN | PAOLO CASTELLI



Metal Finish
Matt Gold

La collezione Best World apre la serie di specchi luminosi di varie forme e dimensioni adatti a molti tipi di ambienti, come eleganti camere padronali, ingressi e diversi ambienti della casa. Best World è composto da un grande specchio di diverse dimensioni con raffinata cornice in metallo arricchita dalla preziosa finitura oro opaco satinato. Ogni pezzo della collezione è dotato, lungo tutto il perimetro, di un moderno sistema illuminante a led che trasforma l'oggetto in una lampada d'atmosfera, riducendo ulteriori fonti luminose nell'ambiente.

È disponibili in tre versioni: Square, Rectangular e Octagonal.

The Best World collection opens the range of luminous mirrors, available in different shapes and dimensions, that can suit a number of different spaces, such as elegant master bedrooms, entrances and other rooms of the house. Best World comprises a large mirror with an exquisite metal frame, boasting an elegant matt gold finish. Each piece of the collection features, along the edge, a modern led lighting system that transforms the mirror into a lamp, creating an atmosphere and reducing other luminous sources in the room.

It is available in three versions: Square, Rectangular and Octagonal.

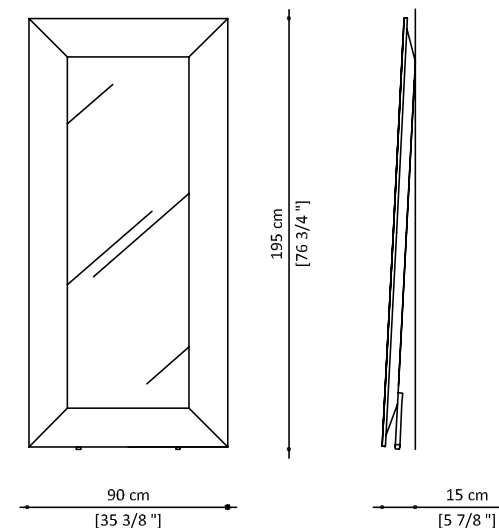

TECHNICAL SHEET

BEST WORLD RECTANGULAR
Light source: Strip Led 12V/24W
Total power: 20W
Voltage: 220 - 240 V
Rated luminous flux: 260 Lm
Colour temperature: 2700° K
Colour rendering index: Ra>80
Dimmer function: no
Cable length: 2 mt
Pin power cable: EU pin
Weight: Kg 80
Package size: 210 x 104 x 40 cm
Package weight: Kg 130

RECTANGULAR | ILL. BEST.510

Mat gold metal frame with led lighting



C



Inspiration

C

BEST WORLD SQUARE

DESIGN | PAOLO CASTELLI



Metal Finish
Matt Gold

La collezione Best World apre la serie di specchi luminosi di varie forme e dimensioni adatti a molti tipi di ambienti, come eleganti camere padronali, ingressi e diversi ambienti della casa. Best World è composto da un grande specchio di diverse dimensioni con raffinata cornice in metallo arricchita dalla preziosa finitura oro opaco satinato. Ogni pezzo della collezione è dotato, lungo tutto il perimetro, di un moderno sistema illuminante a led che trasforma l'oggetto in una lampada d'atmosfera, riducendo ulteriori fonti luminose nell'ambiente.

È disponibili in tre versioni: Square, Rectangular e Octagonal.

The Best World collection opens the range of luminous mirrors, available in different shapes and dimensions, that can suit a number of different spaces, such as elegant master bedrooms, entrances and other rooms of the house. Best World comprises a large mirror with an exquisite metal frame, boasting an elegant matt gold finish. Each piece of the collection features, along the edge, a modern led lighting system that transforms the mirror into a lamp, creating an atmosphere and reducing other luminous sources in the room.

It is available in three versions: Square, Rectangular and Octagonal.

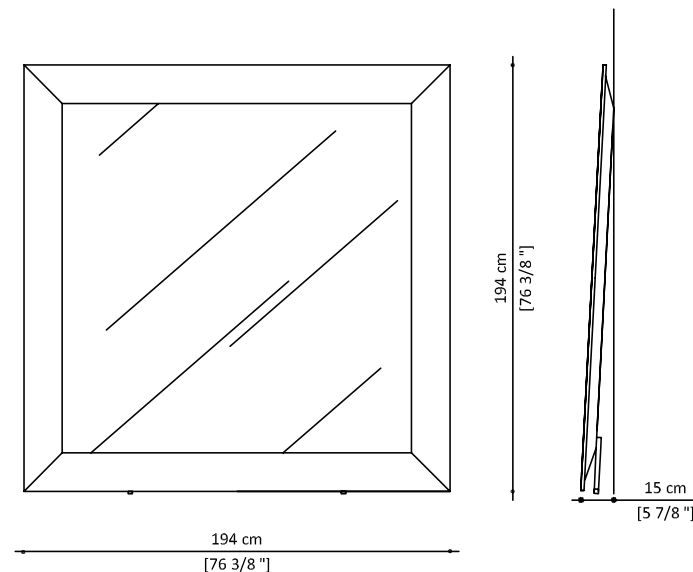

TECHNICAL SHEET

BEST WORLD SQUARE

Light source: Strip Led 12V/24W

Total power: 20W

Voltage: 220 - 240 V

Rated luminous flux: 260 Lm

Colour temperature: 2700° K

Colour rendering index: Ra>80

Dimmer function: no

Cable lenght: 2 mt

Pin power cable: EU pin

Weight: Kg 110

Package size: 210 x 210 x 40 cm

Package weight: Kg 180

SQUARE | ILL. BEST.520

Mat gold metal frame with led lighting



C



Inspiration



BEST WORLD ROUND

DESIGN | PAOLO CASTELLI



Metal Finish
Matt Gold

La collezione Best World apre la serie di specchi luminosi di varie forme e dimensioni adatti a molti tipi di ambienti, come eleganti camere padronali, ingressi e diversi ambienti della casa. Best World è composto da un grande specchio di diverse dimensioni con raffinata cornice in metallo arricchita dalla preziosa finitura oro opaco satinato. Ogni pezzo della collezione è dotato, lungo tutto il perimetro, di un moderno sistema illuminante a led che trasforma l'oggetto in una lampada d'atmosfera, riducendo ulteriori fonti luminose nell'ambiente.

È disponibile in quattro versioni: Square, Rectangular, Octagonal, Square.

The Best World collection opens the range of luminous mirrors, available in different shapes and dimensions, that can suit a number of different spaces, such as elegant master bedrooms, entrances and other rooms of the house. Best World comprises a large mirror with an exquisite metal frame, boasting an elegant matt gold finish. Each piece of the collection features, along the edge, a modern led lighting system that transforms the mirror into a lamp, creating an atmosphere and reducing other luminous sources in the room.

It is available in four versions: Square, Rectangular, Octagonal, Round.

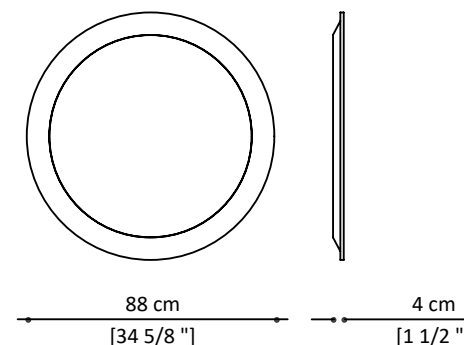

TECHNICAL SHEET

BEST WORLD ROUND

Light source: Strip Led 12V/24W

Total power: 20W

Voltage: 220 - 240 V

Rated luminous flux: 260 Lm

Colour temperature: 2700° K

Colour rendering index: Ra>80

Dimmer function: no

Cable length: 2 mt

Pin power cable: EU pin

Weight: Kg 80

Package size: 160 x 160 x 40 cm

Package weight: Kg 140

ROUND | ILL. BEST.540

Mat gold metal frame with led lighting

2.900,00€



Inspiration



GASPERINI MIRROR

DESIGN | PAOLO CASTELLI



Straw yellow
stone



Metal Finish
Matt Gold

Specchio da tavolo dalle forme geometriche pure, dai materiali preziosi (oro chiaro satinato e pietra giallo paglierino) e da un tocco di contemporaneità data dal led che incornicia lo specchio. Lo specchio Gasperini nasce da un ricordo di infanzia di Paolo Castelli, designer della collezione. Prende infatti il nome dal nonno sarto che aveva al centro del suo atelier uno specchio trittico.

Free-standing table mirror, with pure geometric shapes, precious materials (satin finish light gold and straw yellow stone) and a contemporary touch lent by the mirror's LED frame. Gasperini mirror were inspired by a childhood memory of Paolo Castelli, designer of the collection. It is named after his grandfather, a tailor who had a triptych mirror at the centre of his workshop.

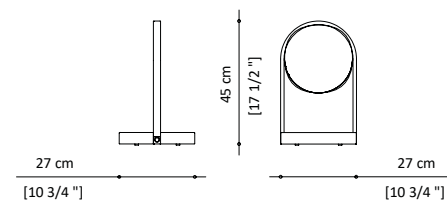

GASPERINI || ILL.GASP.510
Matt finish light gold and straw yellow stone



CE



Inspiration



MURANO VASES

DESIGN | PAOLO CASTELLI



Murano
Glass
Col. Ice Grey



Murano Glass
Col. Tabacco

Un arcobaleno di nuovi vasi arredo testimoni per eccellenza della creatività artigiana muranese declinata in opera d'arte. L'attuale risultato di questa preziosa collaborazione, sempre tesa a coniugare saperi antichi ed estetica contemporanea, è un'inedita sperimentazione di cromie pastello, trasparenti o opaline e forme.

Completano questa ricerca tre diverse lavorazioni: battuto, a coste e le caratteristiche bolle e sfere specchiate.

A rainbow of new decorative vases that reflect par excellence the creativity of Murano craftsmanship expressed as a work of art. The current outcome of this precious collaboration, always aimed at coupling ancient knowledge and contemporary aesthetics, is an unprecedented experimentation of pastel, transparent and milk-glass colours and forms.

Three different manufacturing techniques complete this research: battuto finish, ribbed, and the characteristic air bubbles and mirrored spheres.

COSTE

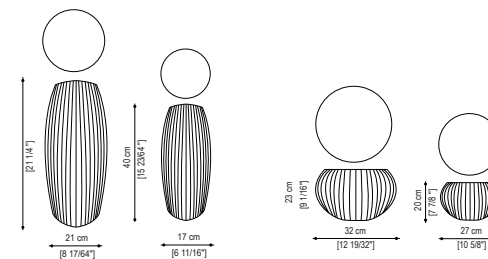

VASO SMALL | COM.VASE.DON.002

Murano glass

Available colors: Pagliesco (Champagne) - Tabacco (Bronze) - Red - Blue - Musk green - Ice Grey

VASO BIG | COM.VASE.DON.001

Murano glass

Available colors: Pagliesco (Champagne) - Tabacco (Bronze) - Red - Blue - Musk green - Ice Grey

COPPA SMALL | COM.VASE.DON.004

Murano glass

Available colors: Pagliesco (Champagne) - Tabacco (Bronze) - Red - Blue - Musk green - Ice Grey

COPPA BIG | COM.VASE.DON.003

Murano glass

Available colors: Pagliesco (Champagne) - Tabacco (Bronze) - Red - Blue - Musk green - Ice Grey

BOLLE

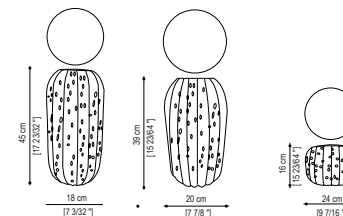

BOLLE VASO SMALL | COM.VASE.DON.006

Murano glass

Available colors: Pagliesco (Champagne) - Tabacco (Bronze) - Red - Blue - Musk green - Ice Grey

BOLLE COPPA SMALL | COM.VASE.DON.007

Murano glass

Available colors: Pagliesco (Champagne) - Tabacco (Bronze) - Red - Blue - Musk green - Ice Grey

BOLLE VASO BIG | COM.VASE.DON.005

Murano glass

Available colors: Pagliesco (Champagne) - Tabacco (Bronze) - Red - Blue - Musk green - Ice Grey

MURANO VASES

DESIGN | PAOLO CASTELLI

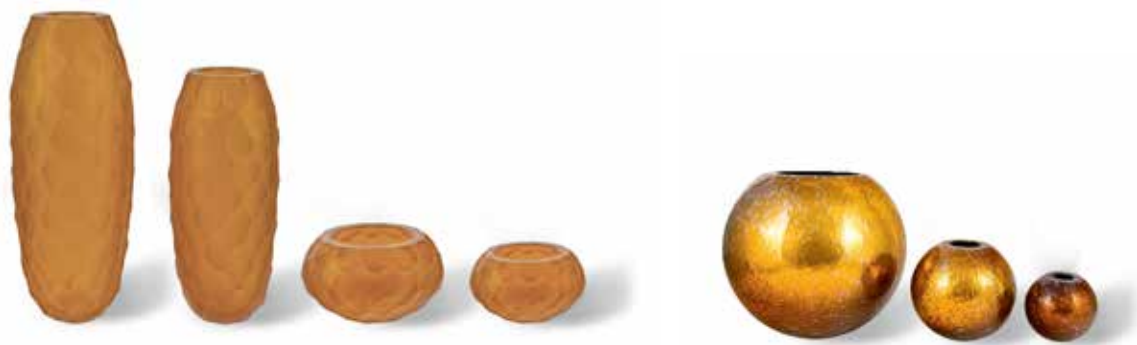

Murano Glass
Col. Tabacco



Murano Glass
Col. Gold

Un arcobaleno di nuovi vasi arredo testimoni per eccellenza della creatività artigiana muranense declinata in opera d'arte. L'attuale risultato di questa preziosa collaborazione, sempre tesa a coniugare saperi antichi ed estetica contemporanea, è un'inedita sperimentazione di cromie pastello, trasparenti o opaline e forme. Completano questa ricerca tre diverse lavorazioni: battuto, a coste e le caratteristiche bolle e sfere specchiate.

A rainbow of new decorative vases that reflect par excellence the creativity of Murano craftsmanship expressed as a work of art. The current outcome of this precious collaboration, always aimed at coupling ancient knowledge and contemporary aesthetics, is an unprecedented experimentation of pastel, transparent and milk-glass colours and forms. Three different manufacturing techniques complete this research: battuto finish, ribbed, and the characteristic air bubbles and mirrored spheres.

BATTUTO

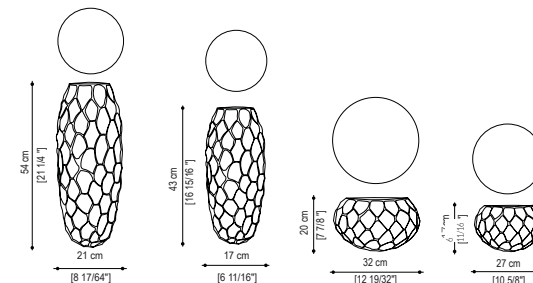

VASO SMALL | COM.VASE.DON.009

Murano glass

Available colors: Pagliesco (Champagne) - Tabacco (Bronze) - Red - Blue- Musk green - Ice Grey

VASO BIG | COM.VASE.DON.008

Murano glass

Available colors: Pagliesco (Champagne) - Tabacco (Bronze) - Red - Blue- Musk green - Ice Grey

COPPA SMALL | COM.VASE.DON.011

Murano glass

Available colors: Pagliesco (Champagne) - Tabacco (Bronze) - Red - Blue- Musk green - Ice Grey

COPPA BIG | COM.VASE.DON.010

Murano glass

Available colors: Pagliesco (Champagne) - Tabacco (Bronze) - Red - Blue- Musk green - Ice Grey

SFERE

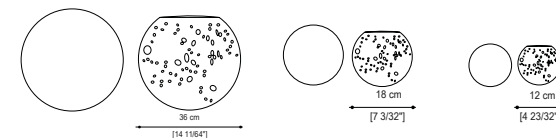

SMALL | COM.VASE.DON.014

Murano glass

Available colors: Gold - Silver

MEDIUM | COM.VASE.DON.013

Murano glass

Available colors: Gold - Silver

BIG | COM.VASE.DON.012

Murano glass

Available colors: Gold - Silver





TAILOR MADE CARPETS



Pregiati tappeti realizzati a mano, con disegni contemporanei declinati in sette modelli. A garanzia dell'artigianalità del tappeto, possono presentarsi irregolarità nella tessitura e variazioni di tonalità tra un bagno di colore e l'altro dei filati.

Precious handmade carpets with contemporary design in seven models. As a guarantee of a craft product, there may be irregularities in the weave and variations of shade between one dyeing batch and the next.



PARIGI 400x300 cm
COM.CARP.SAH.001

Superior taftato in wool and bamboo silk with carving.
Base in wool BMB08.
Design 1: bamboo silk D006 with carving.
Design 2: bamboo silk D005 with carving.
Color: Ice



SHANGHAI 300x400 cm
COM.CARP.SAH.002

Hand-crafted taftato superior in wool and viscose in relief.
Wood: AE12, Viscose: A075
Color: taupe



BOLOGNA 300x260 cm
COM.CARP.SAH.010

Hand-crafted taftato superior, silk and wool in relief.
Base in bamboo silk: H12. Design in wool in relief I008.
Color: Moka



MILANO 300x400 cm
COM.CARP.SAH.003

Hand-crafted taftato superior, wool and viscose in relief.
Wool: AF09, Viscose: A117.
Color: Sand



NEW DELHI 400x400 cm
COM.CARP.SAH.009

Taftato superior in viscose with carving. Base in Viscose 02A.
Design with carving in Viscose 03B,
Color: Ivory

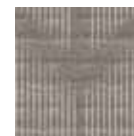

CARRARA 400 x 400 cm
COM.CARP.SAH.004

Taftato superior in silk bamboo and wool in relief.
Base in bamboo silk A019. Design in wool in relief AD11.
Color: cream



BEIJING Ø 300 cm
COM.CARP.SAH.008

Taftato superior in wool with carving, base in wool BM04.
Design with carving in wool AF11
Color: silver

TAILOR MADE CARPETS



Pregiati tappeti realizzati a mano, con disegni contemporanei declinati in sette modelli. A garanzia dell'artigianalità del tappeto, possono presentarsi irregolarità nella tessitura e variazioni di tonalità tra un bagno di colore e l'altro dei filati.

Precious handmade carpets with contemporary design in seven models. As a guarantee of a craft product, there may be irregularities in the weave and variations of shade between one dyeing batch and the next.

LUXURY VE



200 x 300 cm | COM.CARP.LUX.002
100% LuxuryVE 6.6. Luxury comfort packing
Colours available: latte (milk), Ecrú (raw), tortora scuro (dark turtledove), Nero (black).

300 x 300 cm | COM.CARP.LUX.001
100% LuxuryVE 6.6. Luxury comfort packing
Colours available: latte (milk), Ecrú (raw), tortora scuro (dark turtledove), Nero (black).

300 x 400 cm | COM.CARP.LUX.003
100% LuxuryVE 6.6. Luxury comfort packing
Colours available: latte (milk), Ecrú (raw), tortora scuro (dark turtledove), Nero (black).

400 x 400 cm | COM.CARP.LUX.004
100% LuxuryVE 6.6. Luxury comfort packing
Colours available: latte (milk), Ecrú (raw), tortora scuro (dark turtledove), Nero (black).

Ø 300 cm | COM.CARP.LUX.006
100% LuxuryVE 6.6. Luxury comfort packing
Colours available: latte (milk), Ecrú (raw), tortora scuro (dark turtledove), Nero (black).

VELVET PHA



200 x 300 cm | COM.CARP.VEL.018
100% Viscose Double backing lattelx and cotton, Handloom
Colours available: Egg Blue, Beige, Coal grey, Taupe grey

300 x 300 cm | COM.CARP.VEL.009
100% Viscose Double backing lattelx and cotton, Handloom
Colours available: Egg Blue, Beige, Coal grey, Taupe grey

300 x 400 cm | COM.CARP.VEL.001
100% Viscose Double backing lattelx and cotton, Handloom
Colours available: Egg Blue, Beige, Coal grey, Taupe grey

400 x 400 cm | COM.CARP.VEL.002
100% Viscose Double backing lattelx and cotton, Handloom
Colours available: Egg Blue, Beige, Coal grey, Taupe grey

Ø 300 cm | COM.CARP.VEL.003
100% Viscose Double backing lattelx and cotton, Handloom
Colours available: Egg Blue, Beige, Coal grey, Taupe grey

CUSHIONS DECORATIVE

DESIGN | PAOLO CASTELLI

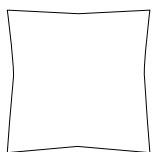

45 x 45 cm

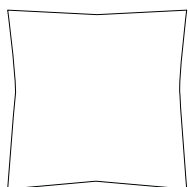

50 x 50 cm



30 x 50 cm

Soffici cuscini resi morbidi ed accoglienti grazie ad un'imbottitura realizzata in soffice piuma d'oca. Tutti i cuscini sono impreziositi da piping in tinta.

Soft cushions made soft and cozy thanks to a stuffing made of soft goose down. All the cushions are embellished with matching piping.

45x45 FABRIC SUPERIOR | SED.CUSH.630.SUP
Fabric Superior

45x45 FABRIC DELUXE | SED.CUSH.630.DEL
Fabric Deluxe

45x45 FABRIC DECORATIVE | SED.CUSH.630.DEC
Fabric Decorative

45x45 LEATHER | SED.CUSH.630.PEL
Leather

45x45 FABRIC NABUK | SED.CUSH.630.NAB
Nabuk

50x50 FABRIC SUPERIOR | SED.CUSH.620.SUP
Fabric Superior

50x50 FABRIC DELUXE | SED.CUSH.620.DEL
Fabric Deluxe

50x50 FABRIC DECORATIVE | SED.CUSH.620.DEC
Fabric Decorative

50x50 LEATHER | SED.CUSH.620.PEL
Leather

50x50 FABRIC NABUK | SED.CUSH.620.NAB
Nabuk

30x50 FABRIC SUPERIOR | SED.CUSH.640.SUP
Fabric Superior

30x50 FABRIC DELUXE | SED.CUSH.640.DEL
Fabric Deluxe

30x50 FABRIC DECORATIVE | SED.CUSH.640.DEC
Fabric Decorative

30x50 LEATHER | SED.CUSH.640.PEL
Leather

30x50 FABRIC NABUK | SED.CUSH.640.NAB
Nabuk



LUCI
LIGHTING

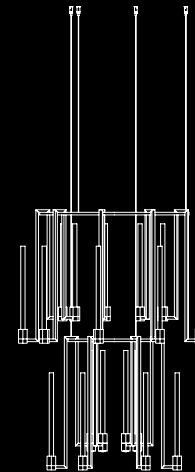
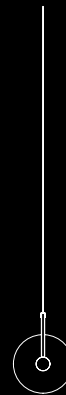
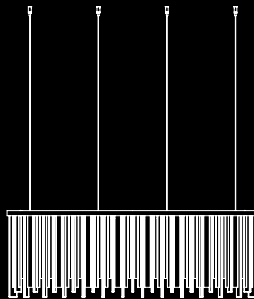
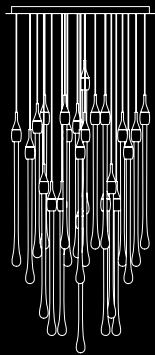
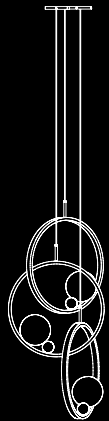

Inspiration



MY LAMP SUSPENSION

DESIGN | PAOLO CASTELLI



Metal Finish
Matt Gold

My Lamp Round di diametro 50 e 100 cm, sono lampadari tondi che possono creare un effetto dinamico e di forte impatto se disposto in più pezzi. Ideale per salotti e sale da pranzo raffinati dove si vuole creare un ambiente sofisticato ma non convenzionale. È composto da un importante bouquet di tubi realizzati in vetro borosilicato veneziano posti ad altezze sfasate e raccolti in una fascia metallica curvata, trattata con particolare finitura a più strati oro opaco. Il telaio portante interno è realizzato in metallo nichelato. Contropiastra opalescente per diffondere la luce.

My Lamp Round with 50 and 100 cm diameter are round hanging lamps that bring a dynamic effect and have a great visual impact in arrangements with multiple pieces. Ideal in elegant lounges and dining rooms that want to create a sophisticated but unconventional ambience.

It comprises a significant "bouquet" of venetian borosilicate glass tubes, hanging from different heights, bound together by a curved metal band with a unique finish mat gold.

The internal supporting frame is made of nickel-plated metal. Opalescent counterplate to diffuse the light.

SUSPENSION ROUND 50

TECHNICAL SHEET
MY LAMP ROUND 50
Light source: STRIP LED 8W/M
Total power: 55 W
Voltage: 110 - 240 V
Rated luminous flux: 4420 Lm
Colour temperature: 2700° K
Colour rendering index: Ra80
Suspension cable length: 150 cm
Dimmer function: Yes
Weight: Kg 40
Package size: 71 x 71 x 78 cm
Package weight: Kg 65

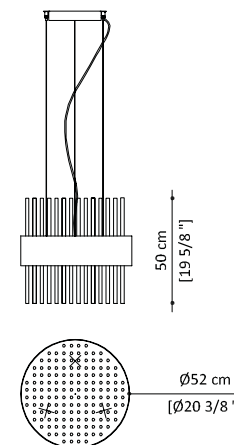

SUSPENSION ROUND 50 | ILL.MYLA.201

Mat gold finish

SUSPENSION ROUND 100

TECHNICAL SHEET
MY LAMP ROUND 100
Light source: STRIP LED 8W/M
Total power: 128 W
Voltage: 115 - 230 V
Rated luminous flux: 9750 Lm
Colour temperature: 2700° K
Colour rendering index: Ra80
Dimmer function: Yes
Weight: Kg 130
Package size: 125 x 125 x 90 cm
Package weight: Kg 170

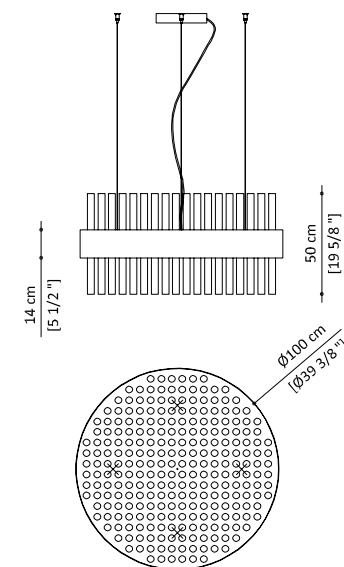

SUSPENSION ROUND 100 | ILL.MYLA.200

Mat gold finish



◀ **Bouquet di tubi realizzati in vetro borosilicato veneziano.**

Bouquet of glass tubes made of Venetian borosilicate glass.

Inspiration



MY LAMP SUSPENSION

DESIGN | PAOLO CASTELLI

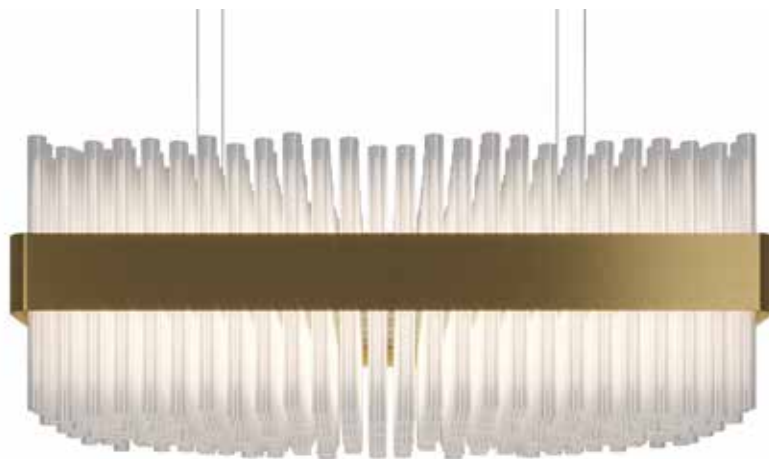

Metal Finish
Matt Gold

My Lamp Rectangular e Square, sono lampadari che possono creare un effetto dinamico e di forte impatto se disposto in più pezzi. Ideale per salotti e sale da pranzo raffinati dove si vuole creare un ambiente sofisticato ma non convenzionale. È composto da un importante bouquet di tubi realizzati in vetro borosilicato veneziano posti ad altezze sfasate e raccolti in una fascia metallica curvata, trattata con particolare finitura a più strati oro opaco. Il telaio portante interno è realizzato in metallo nichelato. Contropiastra opalescente per diffondere la luce.

My Lamp Rectangular and Square are hanging lamps that bring a dynamic effect and have a great visual impact in arrangements with multiple pieces. Ideal in elegant lounges and dining rooms that want to create a sophisticated but unconventional ambiente. It comprises a significant "bouquet" of venetian borosilicate glass tubes, hanging from different heights, bound together by a curved metal band with a unique finish mat gold. The internal supporting frame is made of nickel-plated metal. Opalescent counterplate to diffuse the light.

SUSPENSION SQUARE

TECHNICAL SHEET
MY LAMP SQUARE
Light source: STRIP LED 8W/M
Total power: 115 W
Voltage: 110 - 230 V
Rated luminous flux: 9360 Lm
Colour temperature: 2700° K
Colour rendering index: Ra80
Suspension cable length: 200 cm
Dimmer function: Yes
Weight: Kg 100
Package size: 111 x 111 x 93 cm
Package weight: Kg 155

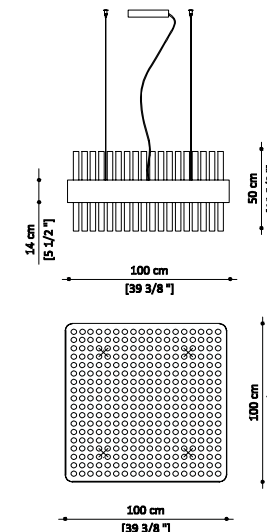

SUSPENSION SQUARE | ILL.MYLA.210

Mat gold finish

SUSPENSION RECTANGULAR

TECHNICAL SHEET
MY LAMP RECTANGULAR
Light source: STRIP LED 12W/M
Total power: 132 W
Voltage: 12 V
Rated luminous flux: 7200 Lm
Colour temperature: 2700° K
Colour rendering index: Ra80
Suspension cable length: 200 cm
Dimmer function: Yes
Weight: Kg 132
Package size: 125 x 125 x 90 cm
Package weight: Kg 200

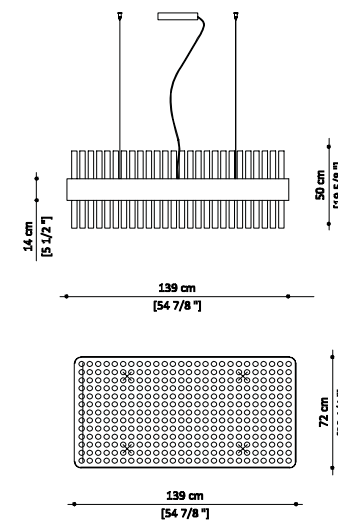

SUSPENSION RECTANGULAR | ILL.MYLA.220

Mat gold finish



C



Inspiration



MY LAMP SPHERE

DESIGN | PAOLO CASTELLI



Metal Finish
Matt Gold

My Lamp Sphere è composto da un importante bouquet di tubi realizzati in vetro borosilicato veneziano posti ad altezze sfasate e raccolti in una fascia metallica curvata, trattata con particolare finitura a più strati oro opaco.

Il telaio portante interno è realizzato in metallo nichelato.

My Lamp Sphere comprises a significant "bouquet" of venetian borosilicate glass tubes, hanging from different heights, bound together by a curved metal band with a unique finish mat gold. The internal supporting frame is made of nickel-plated metal.

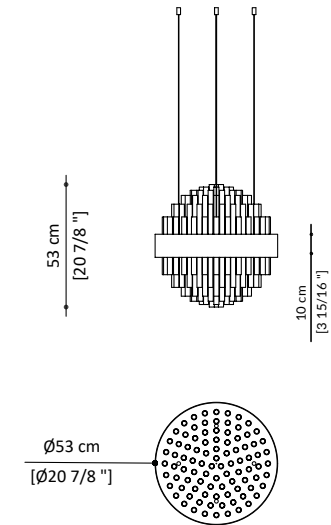

TECHNICAL SHEET

MY LAMP SPHERE

Light source: STRIP LED

Total power: 40 W

Voltage: 12-24 V

Rated luminous flux: 7200 Lm

Colour temperature: 2700° K

Colour rendering index: Ra>80

Suspension cable length: 150 cm

Dimmer function: Yes

Weight: Kg 36

Package size: 72 x 72 x 75 cm

Package weight: Kg 78

SUSPENSION SPHERE | ILL.MYLA.2015

Mat gold finish



C



Inspiration

MY LAMP CEILING

DESIGN | PAOLO CASTELLI



Metal Finish
Matt Gold

My lamp ceiling è una plafoniera circolare fortemente scenografica, che attraverso le diverse altezze dei vetri illuminati crea un decoro dinamico e raffinato. È composta da un importante bouquet di tubi realizzati in vetro borosilicato veneziano e raccolti in una fascia metallica curvata, trattata con particolare finitura oro opaco. Il telaio portante interno è realizzato in metallo nichelato. Disponibile in 2 misure.

My lamp ceiling is a round lamp with a great visual impact, which adds a dynamic and elegant touch thanks to the different heights of lit glass elements. It comprises a significant "bouquet" of venetian borosilicate glass tubes bound together by a curved metal band mat gold finished. The internal supporting structure has a nickel metal finish.



CEILING ROUND 100

TECHNICAL SHEET
MY LAMP CEILING ROUND 100
Light source: STRIP LED 8W/M
Total power: 60,5 W
Voltage: 115 - 230 V
Rated luminous flux: 4615 Lm
Colour temperature: 2700° K
Colour rendering index: Ra80
Dimmer function: Yes
Weight: Kg 120
Package size: 125 x 125 x 90 cm
Package weight: Kg 160

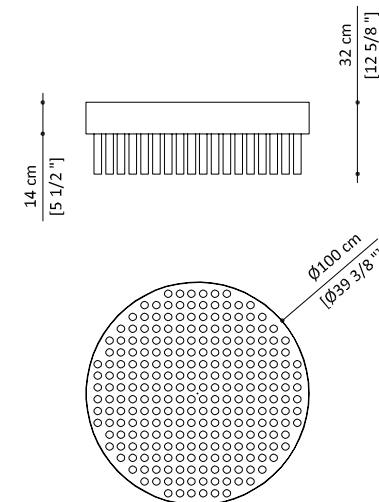

CEILING ROUND 100 | ILL.MYLA.300

Mat gold finish

CEILING ROUND 140

TECHNICAL SHEET
MY LAMP CEILING ROUND 140
Light source: STRIP LED 11W/M
Total power: 108 W
Voltage: 110 - 230 V
Rated luminous flux: 11.500 Lm
Colour temperature: 2700° K
Colour rendering index: Ra80
Dimmer function: Yes
Weight: Kg 150
Package size: 160 x 160 x 90cm
Package weight: Kg 350

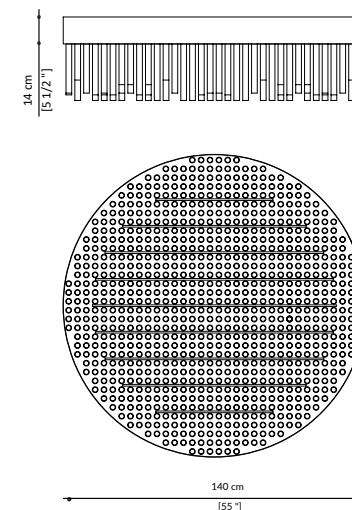

CEILING ROUND 140 | ILL.MYLA.302

Mat gold finish



3



Inspiration



LABILIS COMPOSITION

DESIGN | PAOLO CASTELLI



Metal Black
Matt varnished



Metal Finish
Matt Bronzed
Brass

Un nuovo alfabeto grafico fatto di essenziali elementi geometrici che disegnano nello spazio contemporanee forme di luce. Tre anelli di diverso diametro installabili singolarmente o in composizione da 4, 7 e 10 anelli. L'anello in metallo è finitura nero opaco con diffusore di luce led in policarbonato opalino bianco perimetrale. Ogni anello monta uno spot in ottone finitura bronzo ottone opaco. Gli anelli presentano tre cavi di sospensione, di cui uno di alimentazione. Cavi elettrici della lunghezza di due mt.

Optionals su richiesta: anelli dimmerabili; rosoni cilindrici in metallo con alimentator interno, adatto per installazione a soffitto.



Rosone cilindrico in metallo con alimentatore interno, adatto per installazione a soffitto (optional)*.

Metal cylindrical rose holding local drivers, suitable for ceiling installation (optional)*.

Dim. Ø9 x h 20cm

A new graphic alphabet consisting of essential geometric elements that create contemporary light forms in the space. Three rings in different diameters can be installed separately or as composition (4, 7, 10 rings).

The metal ring is in satin black finish, with light diffuser in white opal polycarbonate along the perimeter. Each ring carries a LED spot in mat brass bronze finish. Each ring has three suspension cables, one of which is a power supply one. Electric cables are two meters long.

Optionals available on request: dimmable rings; metal cylindrical roses holding local drivers, suitable for ceiling installation.

4 RINGS

TECHNICAL SHEET 4 RINGS

Light source: Strip Led 140 Led/m + spot led(4X)
Total power: 35W - Strip led 14,4W/m; spot 4,2W (10X)
Voltage: 230 V
Rated luminous flux spots: 1320Lm
Rated luminous flux strip led: 6357 Lm
Colour temperature: 2700° K
Colour rendering index: 90
Dimmer function: Yes - only for rings
Cables lenght: 2mt
Weight: 18 Kg

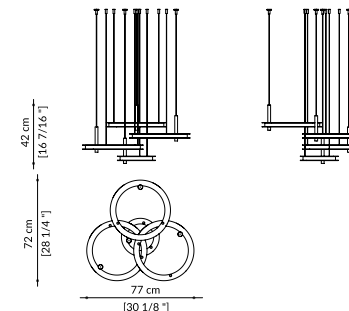

4 RINGS | ILL.LABI.230

1 ring Ø27 + 3 rings Ø43 in metal matt black varnished and led spots in matt bronzed brass
Remote drivers

OPTIONAL*

4 metal cylindrical roses holding local drivers, suitable for ceiling installation

7 RINGS

TECHNICAL SHEET 7 RINGS

Light source: Strip Led 140 Led/m + spot led(7X)
Total power: 77W - Strip led 14,4W/m; spot 4,2 W(7X)
Voltage: 230 V
Rated luminous flux spots: 2310 Lm
Rated luminous flux strip led: 14928 Lm
Colour temperature: 2700° K
Colour rendering index: 90
Dimmer function: Yes - only for rings
Cables lenght: 2mt
Weight: 40 Kg

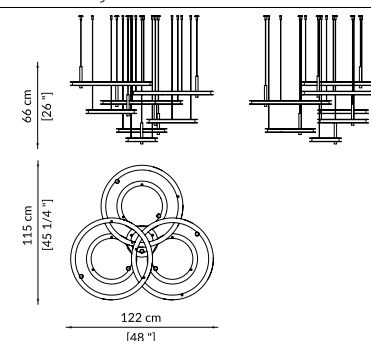

7 RINGS | ILL.LABI.220

1 ring Ø27 + 3 rings Ø43 + 3 rings Ø70 in metal matt black varnished and led spots in matt bronzed brass
Remote drivers

OPTIONAL*

N°7 metal cylindrical roses holding local drivers, suitable for ceiling installation

10 RINGS

TECHNICAL SHEET 10 RINGS

Light source: Strip Led 140 Led/m + spot led(10X)
Total power: 97W - Strip led 14,4W/m; spot 4,2W (10X)
Voltage: 230 V
Rated luminous flux spots: 3300Lm
Rated luminous flux strip led: 17541 Lm
Colour temperature: 2700° K
Colour rendering index: 90
Dimmer function: Yes- only for rings
Cables lenght: 2mt
Weight: 48 Kg

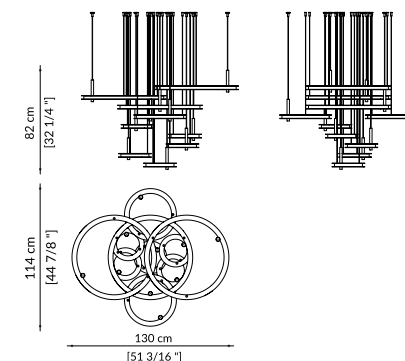

10 RINGS | ILL.LABI.210

N° 10 tubes spot LED I finish matt bronzed brass
5 rings Ø27 + 2 rings Ø43 + 3 rings Ø70 in metal matt black varnished and led spots in matt bronzed brass
Remote drivers

OPTIONAL*

N°10 metal cylindrical roses holding local drivers, suitable for ceiling installation

Inspiration

LABILIS RINGS

DESIGN | PAOLO CASTELLI



Metal Black
Matt varnished



Metal Finish
Matt Bronzed
Brass

Tre anelli di diverso diametro installabili singolarmente o in composizione da 4, 7 e 10 anelli. L'anello in metallo è finitura nero opaco con diffusore di luce led in policarbonato opalino bianco perimetrale. Ogni anello monta uno spot in ottone finitura bronzo ottone opaco. Gli anelli presentano tre cavi di sospensione, di cui uno di alimentazione. Cavi elettrici della lunghezza di due mt.

Optionals su richiesta: anelli dimmerabili; rosone cilindrico in metallo con alimentatore interno, adatto per installazione a soffitto.



Rosone cilindrico*
per soluzione con installazione
degli alimentatori a soffitto
(optional).

Cylindrical rose * suitable for
installation with ceiling power
supplies (optional).

Dim. Ø9 x h 20cm

Three rings in different diameters can be installed separately or as composition (4, 7, 10 rings). The metal ring is in satin black finish, with light diffuser in white opal polycarbonate along the perimeter. Each ring carries a LED spot in mat brass bronze finish. Each ring has three suspension cables, one of which is a power supply one. Electric cables are two meters long.

Optionals available on request: dimmable rings; metal cylindrical rose holding local driver, suitable for ceiling installation.



RING Ø27

TECHNICAL SHEET LABILIS Ø27

Light source: Strip Led 140 Led/m + spot led
Total power: 7,3W - Strip led 14,4W/m; spot 4,2W
Voltage: 230 V
Rated luminous flux spot: 330 Lm
Rated luminous flux strip led: 1092 Lm
Colour temperature: 2700°K
Colour rendering index: 90
Dimmer function: Yes - only for ring
Weight: 2,8 Kg

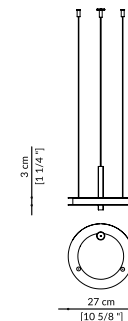

RING Ø27 | ILL.LABI.231

1 ring Ø27 in metal matt black varnished and led spot in matt bronzed brass
Remote drivers

OPTIONAL*

Metal cylindrical rose holding local driver, suitable for ceiling installation

RING Ø43

TECHNICAL SHEET LABILIS Ø43

Light source: Strip Led 140 Led/m + spot led
Total power: 9,7W - Strip led 14,4W/m; spot 4,2W
Voltage: 230 V
Rated luminous flux spots: 330 Lm
Rated luminous flux strip led: 1755 Lm
Colour temperature: 2700°K
Colour rendering index: 90
Dimmer function: Yes - only for ring
Weight: 4,5 Kg

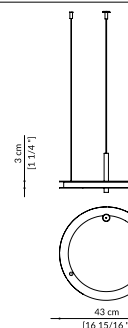

RING Ø43 | ILL.LABI.221

1 ring Ø43 in metal matt black varnished and led spot in matt bronzed brass
Remote drivers

OPTIONAL*

Metal cylindrical rose holding local driver, suitable for ceiling installation

RING Ø70

TECHNICAL SHEET LABILIS Ø70

Light source: Strip Led 140 Led/m + spot led
Total power: 13,6W - Strip led 14,4W/m; spot 4,2W
Voltage: 230 V
Rated luminous flux spots: 330 Lm
Rated luminous flux strip led: 2857 Lm
Colour temperature: 2700°K
Colour rendering index: 90
Dimmer function: Yes - only for ring
Weight: 7,3 Kg

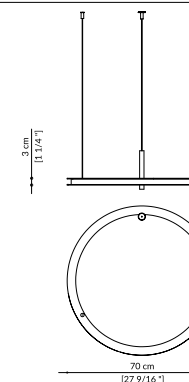

RING Ø70 | ILL.LABI.211

1 ring Ø70 in metal matt black varnished and led spot in matt bronzed brass
Remote drivers

OPTIONAL*

Metal cylindrical rose holding local driver, suitable for ceiling installation





◀ **L'illuminazione tecnica degli spot completa quella decorativa creata dai cerchi luminosi.**

Technical illumination of the spots combined with decorative bright circles.





GOLDEN CLOUD SUSPENSION

DESIGN | PAOLO CASTELLI

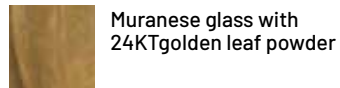

Muranese glass with
24KTgolden leaf powder



Metal Finish
Matt Gold

Prezioso lampadario interamente realizzato a mano secondo le più antiche tradizioni muranesi. Il corpo delle 22 "nuvole" (versione oval con 6 spot integrati) e 23 "nuvole" (versione round, con 5 spot integrati), disposte ad altezze sfalsate, è realizzato in vetro di murano con un triplo passaggio di foglia d'oro e viene modellato a mano in stampo sagomato. La "nuvola" in vetro è agganciata a un corpo metallico in finitura oro satinato e alloggia al suo interno un moderno supporto a led. Il corpo metallico è infine ancorato su una piastra in acciaio, verniciata opaca in bianco, nero, oro. È disponibile in due versioni: Oval e Round.

A refined chandelier made entirely by hand following the most ancient Murano traditions. The body of the 22 "clouds" (Oval version, with 6 built-in spotlights) and 23 "clouds" (Round version, with 5 built-in spotlights), arranged at staggered heights, is made of Murano glass with a triple pass of gold leaf and is formed by hand in a shaped mould. The glass "cloud" is attached to a metal body with a satin gold finish and houses a modern LED fitting. The metal body is anchored onto a steel plate, painted matt in white, black, gold. Available in two versions: Oval and Round.

OVAL

TECHNICAL SHEET GOLDEN CLOUD OVAL

Light source: LED
Glass elements power: 3W x 22
Spots power: 18 W (6 x 3 W)
Voltage: 220 - 240 V
Rated luminous flux: 5000 Lm
Colour temperature: 2700° K
Colour rendering index: Ra>80
Dimmer function: Yes - only for spots
Weight: Kg 71
Package size: 156 x 61 x 39 cm
Package weight: Kg 106
Package volume: Kg 0,37

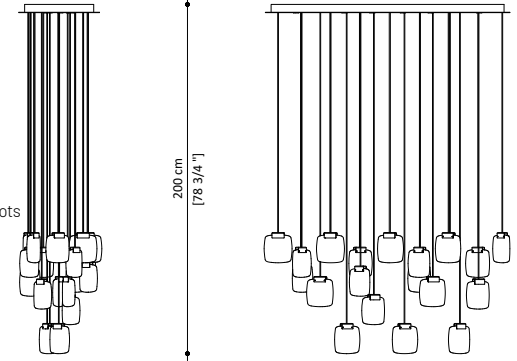

OVAL | ILL.GOLD.230

22 glass pendants and 6 built-in spotlights
Metal cap in mat gold finish - Muranese glass with 24KTgolden leaf powder

ROUND

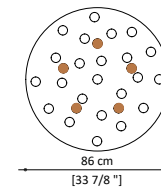

TECHNICAL SHEET GOLDEN CLOUD ROUND

Light source: LED
Glass element power: 3W x 23
Spots power: 15W (5 x 3 W)
Voltage: 220 - 240 V
Rated luminous flux: 5000 Lm
Colour temperature: 2700° K
Colour rendering index: Ra>80
Dimmer function: Yes - only for spots
Weight: Kg 59
Package size: 96 x 96 x 57 cm
Package weight: Kg 94
Package volume: Kg 0,44

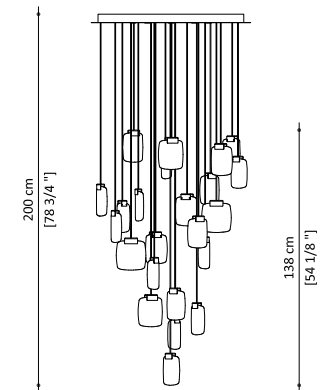

ROUND | ILL.GOLD.220

23 glass pendants and 5 built-in spotlights
Metal cap in mat gold finish - Muranese glass with 24KTgolden leaf powder



C



◀ **Vetro di Murano modellato a mano in stampo sagomato.**

Handcrafted moulded Murano glass.

Inspiration



ALLURE LAMP

DESIGN | PAOLO CASTELLI



Muranese glass with
24KTgolden leaf powder



Satined
Brass

La composizione Allure è un prezioso lampadario interamente realizzato a mano secondo le più antiche tradizioni muranesi.

Il corpo delle 22 gocce (versione oval con 6 spot integrati) e 23 gocce (versione round, con 5 spot integrati), disposte ad altezze sfalsate, è realizzato in vetro di murano pieno, color cristallo veneziano, con incamiciata una preziosa foglia d'oro 24 kt. La bossola superiore è in ottone, e alloggia un moderno supporto a led. La bossola è infine ancorata su una piastra in acciaio, verniciata in finitura oro opaco, bianco o nero.

È disponibile nelle versioni Oval (6 spot led), Round (5 spot led) e Side.

The Allure is an exquisite lamp entirely handcrafted according to traditional murano techniques. The venetian crystal colour drops (n. 22 drops and 6 spots for oval version and n. 23 drops and 5 spots for round version), positioned at different heights, are made in solid murano glass enclosing precious 24 kt gold or silver leaf. In the gold finish, the top cap is made from brass and includes the modern led light support. The top plate is anchored to a steel plate painted mat gold, black or white.

It is available in versions: Oval with six integrated spots, Round with 5 integrated spots, and Side.

OVAL

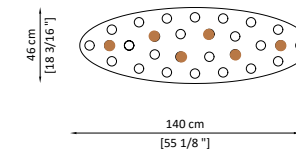

TECHNICAL SHEET

ALLURE OVAL
Light source: Power LED
Glass elements power: 23,1 W (22 x 1,05 W)
Spots power: 18 W (6 x 3 W)
Voltage: 220 - 240 V
Rated luminous flux: 5000 Lm
Colour temperature: 3000° K
Colour rendering index: Ra83
Dimmer function: Yes - only for spots
Weight: Kg 90
Package size: 160 x 60 x 60 cm
Package weight: Kg 106

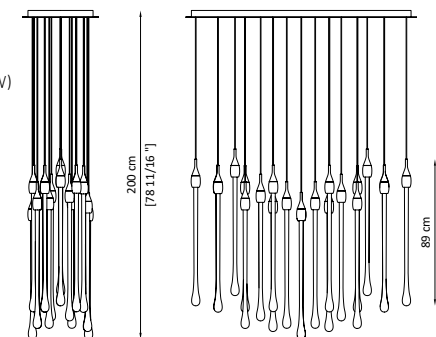

ALLURE OVAL | ILL.ALLU.230

22 glass pendants and 6 built-in spotlights
Metal cap in satined brass - Muranese glass with 24KTgolden leaf powder

ROUND



TECHNICAL SHEET

ALLURE ROUND
Light source: Power LED
Glass elements power: 24,15 W (23 x 1,05 W)
Spots power: 15 W (5 x 3 W)
Voltage: 220 - 240 V
Rated luminous flux: 2860 Lm
Colour temperature: 3000° K
Colour rendering index: Ra83
Dimmer function: Yes - only for spots
Weight: Kg 90
Package size: 96 x 96 x 57 cm
Package weight: Kg 106

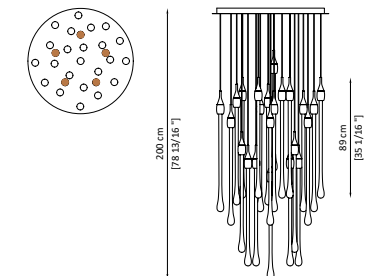

ALLURE ROUND | ILL.ALLU.220

23 glass pendants and 5 built-in spotlights
Metal cap in satined brass - Muranese glass with 24KTgolden leaf powder



◀ **Vetro di Murano soffiato a mano, con polvee d'oro 24K totalmente realizzato a mano, ogni goccia è un pezzo unico.**

Handblown Muranese glass, 24K golden leaf powder. Any glass component is totally handmade so any item is unique.

Inspiration

ALLURE SIDE

DESIGN | PAOLO CASTELLI



Muranese glass with
24KTgolden leaf powder



Satined
Brass

La composizione Allure è un prezioso lampadario interamente realizzato a mano secondo le più antiche tradizioni muranesi.

La versione Side ha 6 gocce realizzate in vetro di murano pieno, color cristallo veneziano, con incamiciata una preziosa foglia d'oro 24 kt.

La bossola superiore è in ottone e alloggia un moderno supporto a led, ed è ancorata su una piastra in acciaio, verniciata in finitura oro opaco, bianco o nero.

La versione Side può avere su richiesta come optional Spot led.

The Allure is an exquisite lamp entirely handcrafted according to traditional murano techniques.

The venetian crystal colour drops (n. 22 drops and 6 spots for oval version and n. 23 drops and 5 spots for round version), positioned at different heights, are made in solid murano glass enclosing precious 24 kt gold or silver leaf. In the gold finish, the top cap is made from brass; while, in the silver finish, it is made from aluminium, and includes the modern led light support. The top plate is anchored to a steel plate painted mat gold, black or white.

SIDE

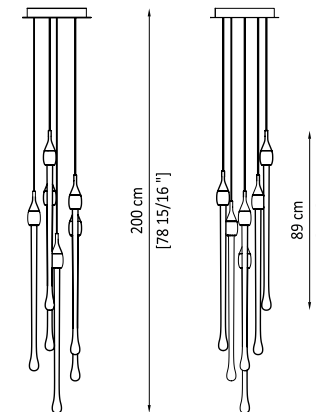
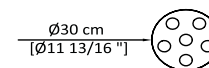

TECHNICAL SHEET

ALLURE SIDE

Light source: Power LED

Glass elements power: 6,30 W (6 x 1,05 W)

Voltage: 220 - 240 V

Rated luminous flux: 2860 Lm

Colour temperature: 3000° K

Colour rendering index: Ra83

Dimmer function: No

Weight: Kg 52

Package size: 68 x 84 x 57 cm

Package weight: Kg 70

Package volume: Kg 0, 33

ALLURE SIDE | ILL.ALLU.200

6 glass pendants

Metal cap in satined brass - Muranese glass with 24KTgolden leaf powder



CE



Inspiration



KALI' CHANDELIER

DESIGN | PAOLO CASTELLI



Muranese glass with
24KTgolden leaf powder



Metal finish
Matt Gold

Chandelier di imponenza scultorea che crea oniriche geometrie di luci tra bracci che sorreggono candele dorate. Kali chandelier vanta una lavorazione creata interamente sulla isola di Murano da storici artigiani. I bracci metallici hanno terminali a sezione esagonale che reggono elementi in vetro che racchiudono all'interno frammenti di foglia oro 24 KT in dispersione. Sotto ai bracci inferiori sono inseriti degli spot light. Illuminazione a led. La lampada è rifinita in finitura oro opaco.

Nella versione a 3 anelli il lampadario king size è perfetto per impreziosire ambienti importanti dalle ampie volumetrie.

Statuesque imposing chandelier, creating dreamlike light geometries among its hands bearing golden candles. Kali chandelier is the result of an artisan handcraft totally made in Murano island. Made of brass, its metal hands - esagonal shaped- hold up glass elements enclosing 24 KT gold leaf particles. Under the below ring there are spot lights. Final finish matt gold.LED lighting .

3-rings model is a king size chandelier perfect for embellishing important halls with large volumes.

2 RINGS

TECHNICAL SHEET

KALI' 2RINGS

Light source: Power LED COB

Total power: 30 led spot x 1W + 6 led spot x 3W

Voltage:230V

Rated luminous flux: 6300 Lm

Colour temperature: 3000° K

Colour rendering index: Ra>80

Dimmer function: Yes - only for spots

Weight: Kg 100

Package size: 115 x 115 x 65 cm

Package weight: Kg 200

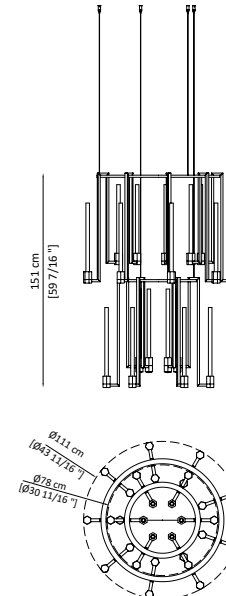

2 RINGS | ILL.KALI.210

Metal finish matt gold

Muranese glass with 24KTgolden leaf powder

3 RINGS

TECHNICAL SHEET

KALI' 3RINGS

Light source: Power LED COB

Total power: 58 led spot x 1W + 6 led spot x 3W

Voltage:230V

Rated luminous flux: 10500 Lm

Colour temperature: 3000° K

Colour rendering index: Ra>80

Dimmer function: Yes - only for spots

Weight: Kg 160

Package size structure: 156 x 136 x 45 cm

Package weight structure: Kg 94

Package size glass candles: 100 x 60 x 70 cm

Package weight structure: Kg 100

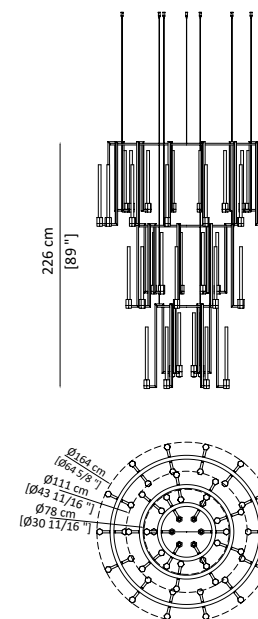

3 RINGS | ILL.KALI.220

Metal finish matt gold

Muranese glass with 24KTgolden leaf powder



C



Inspiration



VENUS CHANDELIER

DESIGN | PAOLO CASTELLI



Metal Finish
Matt Gold



Muranes glass with
24KTgolden leaf powder

Venus diventa un elemento scenografico capace di rendere con la sua suggestiva lavorazione ogni ambiente ricco di una sofisticata luminosità. È composto da un ricco bouquet di elementi metallici a sezione semicircolare e stecche in vetro di murano in cristallo con inclusioni di scaglie oro 24 KT, posti ad altezze sfalsate e raccolti in una fascia metallica luminosa di forma circolare o ovale, trattata con particolare finitura oro opaco a più strati.

Venus is a cinematic element which makes every space rich with a sophisticated brilliance thanks to its suggestive manufacturing. It consists of a rich bouquet of semicircular section metallic elements and Murano glass slats including gold 24 KT flakes, placed at staggered heights and collected in an oval or circular metal band, treated with special finish mat gold.

ROUND

TECHNICAL SHEET

VENUS OVAL

Light source: Strip Led 9,6 W/M + 5 led spot x 3 W

Total power: 63W

Voltage: 230V

Rated luminous flux: 1880 Lm

Colour temperature: 3000° K

Colour rendering index: Ra>80

Suspension cables length: 200 cm

Dimmer function: Yes - only for spots

Weight: Kg 70

Package size structure: 117 x 117 x 40 cm

Package weight structure: Kg 46

Package size glass: 117 x 67 x 80 cm

Package weight glass: Kg 116

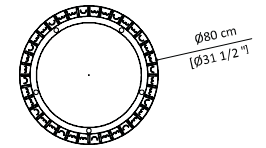
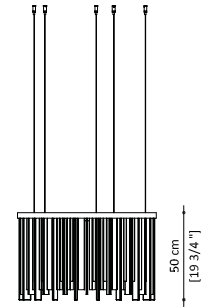

ROUND | ILL. VENU.220

Mat gold finish

Muranes glass with 24KTgolden leaf powder

OVAL

TECHNICAL SHEET

VENUS OVAL

Light source: Strip LED 9,6 W/M + 10 led spot x 3W

Total power: 78W

Voltage: 230V

Rated luminous flux: 2330 Lm

Colour temperature: 3000° K

Colour rendering index: Ra>80

Suspension cables length: 200 cm

Dimmer function: Yes - only for spots

Weight: Kg 110

Package size: 176 x 86 x 54 cm

Package weight: Kg 130

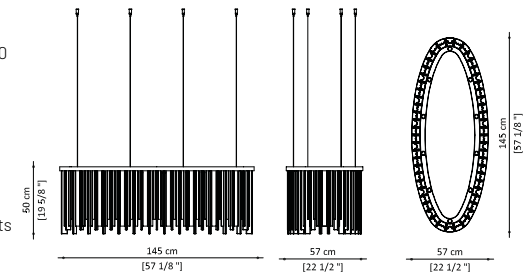

OVAL | ILL. VENU.210

Mat gold finish

Muranes glass with 24KTgolden leaf powder



Inspiration

GOLDEN DISC SUSPENSION

DESIGN | PAOLO CASTELLI



Bovine Leather
Col. 634 Oasi



**Muranese glass with
24KTgolden leaf powder**



Metal Finish
Matt Gold

Il disco di luce è un simbolo antico, universale e fonte infinita di ispirazione. La sua geometria perfetta e leggera, unita alla foglia oro 24Kt, ne esalta la ricercata lavorazione artigianale.

Golden Disc è una lampada a sospensione costituita da un elemento luminoso in vetro di Murano con un triplo passaggio di foglia d'oro, modellato a mano in stampo sagomato.

Il vetro, che riflette la luce e la diffonde nell'ambiente, è incastonato in un disco di metallo finitura oro opaco satinato e sostenuto da un supporto metallico rivestito in pelle color sabbia. Ciascun elemento è fornito di un rosone in metallo finitura oro opaco e di un cavo elettrico di supporto della lunghezza massima di 2 m.

The disc of light is an ancient, universal symbol and never-ending source of inspiration. Its perfect, light geometry, combined with 24-carat gold leaf, enhances its sophisticated craftsmanship.

Golden Disc is a suspension lamp created with hand-moulded lighting element made of Murano glass, coated with three layers of gold leaf.

The glass, which reflects the light and radiates it around the room, is set in a matt gold-finish metal disc and sustained by a metal support upholstered in sand-coloured leather. Each element comes with a rose made of matt gold-finish metal and an electrical support cable with a maximum length of 2 metres.

TECHNICAL SHEET

GOLDEN DISC

Light source: Stripe Led

Total power: 24W

Voltage: 220-240 V

Rated luminous flux: 305 Lm

Colour temperature: 3000° K

Colour rendering index: Ra>90

Dimmer function: No

Weight: Kg 10

Package size: 55 x 50 x 25 cm

Package weight: Kg 26

Package volume: Kg 0,10

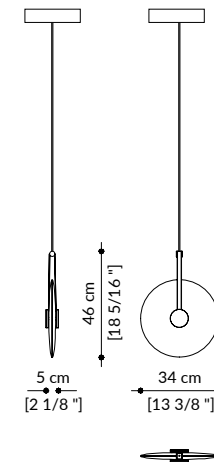

N. 1 ELEMENT | ILL.DISC.200

Metal disc finished matt-gold

Muranese glass with 24KT golden leaf powder





◀ Elementi in vetro di Murano che racchiudono all'interno frammenti di foglia oro 24 KT in dispersione.

Murano glass elements contain sprinkled fragments of 24K golden leaf.

Inspiration

JOY SUSPENSION

DESIGN | VITTORIO PARADISO



Murano Glass
Amaranth



Matt
Brass

La composizione Joy nasce dal tema di dare corpo alla luce. La lampada è composta da tre anelli in ottone, ad altezza variabile, e sfere in vetro soffiato satinato bianco opaco (sfera grande) e rosso amaranto trasparente (sfera piccola) magicamente sospese all'interno della struttura metallica sottile. Un gioco di masse e di traiettorie circolari genera un disegno bilanciato di dinamiche gravitazionali. La luce emanata dalle sfere si diffonde sullo spazio circostante e irraggia il telaio. I riflessi dell'ottone contribuiscono a rendere l'atmosfera ancora più sofisticata e onirica.

Disponibile la versione a un anello e a tre anelli.

Joy composition was born of the idea of giving form to light. The lamp is composed of three brass rings, with variable height, and spheres in hand-blown white satin glass (big sphere) and Amaranth see-through, (small sphere) magically suspended within a thin metal structure. The play of circular masses and trajectories generates a balanced design of gravitational dynamics. The light from the sphere is diffused into the surrounding space, illuminating the frame. The reflections of the brass render the luminous field visible by its aura.

Available versions: one ring, three rings.

1 RING

TECHNICAL SHEET

JOY SUSPENSION 1 RING

Light source: LED

Total power: 1.9 W

Voltage: 220-240 V

Rated luminous flux: 204 Lm

Colour temperature: 2700° K

Colour rendering index: Ra>80

Dimmer function: No

Weight: Kg 10

Package size: 76 x 76 x 49 cm

Package weight: Kg 26

Package volume: Kg 0,28

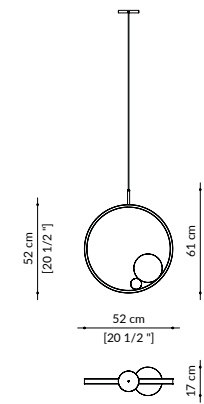

JOY 1 RING | ILL. JOYL.210

1 ceiling canopy

Mat brass ring

Lamp shades in in hand-blown white satin glass

3 decorative glass spheres made in Murano glass col. Amaranth

3 RINGS

TECHNICAL SHEET

JOY SUSPENSION 3 RINGS

Light source: LED

Total power: 5.7 W

Voltage: 220-240 V

Rated luminous flux: 612 Lm

Colour temperature: 2700° K

Colour rendering index: Ra>80

Dimmer function: No

Weight: Kg 15

Package size 1: 68 x 68 x 31 cm

Package weight 1: Kg 5

Package volume: Kg 0,14

Package size 2: 45 x 47 x 35 cm

Package weight 2: Kg 13

Package volume: Kg 0,07

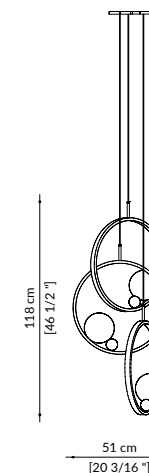

JOY 3 RINGS | ILL. JOYL.200

3 ceiling canopies

Mat brass rings

Lamp shades in in hand-blown white satin glass

Decorative glass sphere made in Murano glass col. Amaranth



◀ Sfera decorativa in vetro soffiato a bocca da artigiani muranesi.

Decorative sphere made by glass-blowing Murano technique.

Inspiration

ROULETTE LAMP

DESIGN | PAOLO CASTELLI



Metal Finish
Bronze
Shadow Mat



Fabric
Silk

Lampada a sospensione di forma cilindrica composta da una struttura in metallo finitura bronzo con paralume interno/esterno in tessuto color avorio, al suo interno è alloggiata una moderna sorgente led. Il paralume è impreziosito esternamente da una fascia esterna rivestita con prezioso tessuto in fibra naturale di colore bronzo scuro, intrecciata manualmente.

Cylindrical shaped suspension lamp composed of a metal structure with a bronze metal finish and an inner/outer shade in ivory-coloured fabric, within which a modern LED light source is housed. The lampshade is embellished externally by a band covered with a fine, hand-woven natural fibre fabric of a dark bronze colour.



Ø 60

TECHNICAL SHEET

ROULETTE 60

Light source: LED 3 W x 22

Total power: 66W

Voltage: 220- 240V

Rated luminous flux: 612 Lm

Colour temperature: 2700° K

Colour rendering index: Ra>80

Dimmer function: No

Weight: Kg 10

Package size: 70 x 70 x 50cm

Package weight: Kg 50

Package volume: Kg 0,25

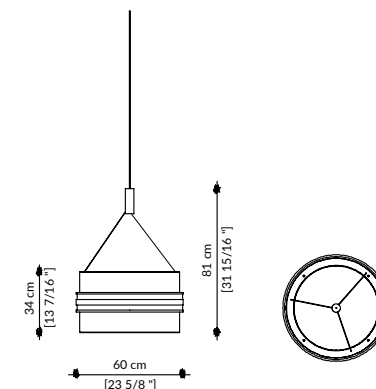

Ø 60 | ILL.ROUL.220

Structure in metal bronze shadow matt finish
Inner/outer shade in ivory-coloured fabric

Ø 90

TECHNICAL SHEET

ROULETTE 90

Light source: LED 3 W x 22

Total power: 66W

Voltage: 220- 240V

Rated luminous flux: 612 Lm

Colour temperature: 2700° K

Colour rendering index: Ra>80

Dimmer function: No

Weight: Kg 26

Package size: 101 x 101 x 54cm

Package weight: Kg 47

Package volume: Kg 0,55

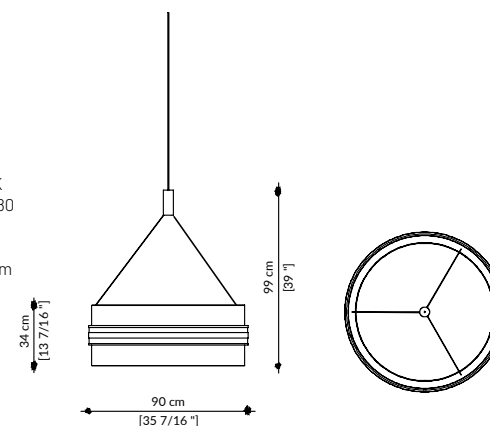

Ø 90 | ILL.ROUL.210

Structure in metal bronze shadow matt finish
Inner/outer shade in ivory-coloured fabric



C



Inspiration



MIDNIGHT SUSPENSION

DESIGN | PAOLO CASTELLI



Glass
Smoked



Metal Finish
Matt Gold

La forma perfetta della sfera si interrompe per dare risalto al calore della materia. Midnight è il risultato dell'unione di due calotte semisferiche in vetro borosilicato fumè, entrambe sospese su di un disco in alluminio, con finitura oro satinato, all'interno è presente una sfera in vetro opalino.

La lampada si aggancia a soffitto con rosone in metallo oro satinato. E' possibile creare composizioni con diversi elementi.

The perfect shape of the sphere is interrupted to emphasize the warmth of the material. Midnight is the result of the union of two semi-spherical caps in smoked borosilicate glass, both suspended on an aluminum disc, with a satin-finish gold finish, inside there is an opal glass sphere.

The lamp is fixed to the ceiling with a rose in satin gold metal. Compositions can be created with several elements.

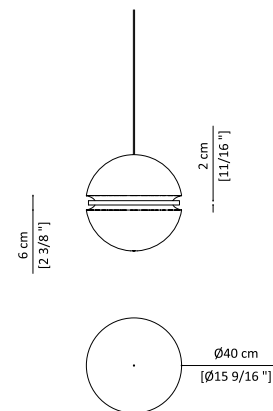

TECHNICAL SHEET

MIDNIGHT

Light source: strip LED + G9

Total power: 18W

Voltage: 220-240V

Rated luminous flux: 2000 Lm

Colour temperature: 2700° K

Colour rendering index: Ra85

Dimmer function: No

Weight: Kg 32

Package size: 61 x 61 x 74 cm

Package weight: Kg 34

Package volume: Kg 0,28

MIDNIGHT | ILL.MIDN.220

Smoked glass

Metal structure mat gold



C



Inspiration



WAVE LAMP

DESIGN | PAOLO CASTELLI



Metal Finish
Matt Gold

Il lampadario WAVE è realizzato con una struttura in metallo di forma ovale, con una speciale finitura oro opaco, che accoglie gli elementi in vetro borosillicato a sezione triangolare di diverse altezze creando un effetto onda lungo tutto il perimetro.

All'interno del perimetro curviforme è posizionata una piastra illuminante con struttura in metallo e pannello in policarbonato opalino che diffonde la luce.

The WAVE chandelier is made of an oval-shaped metal structure, with a special finish mat gold, which houses the borosilicate glass elements in triangular section of different heights creating a wave effect along the entire perimeter.

Inside the curviform perimeter there is a lighting plate with a metal structure and an opal polycarbonate panel that diffuses the light.

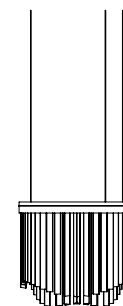

52 cm
[20 1/2 "]

47 cm
[18 9/16 "]

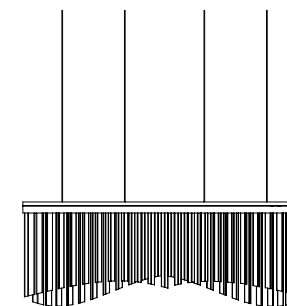

128 cm
[50 1/2 "]

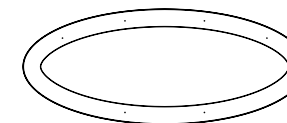

TECHNICAL SHEET WAVE

Light source: LED

Total power: 117W

Voltage: 220-240 V

Rated luminous flux: 5000 Lm

Colour temperature: 3000° K

Colour rendering index: Ra>85

Dimmer function: No

Weight: Kg 52

Package size: 134 x 74 x 63 cm

Package weight: Kg 109

Package volume: Kg 0,63

WAVE SUSPENSION LAMP | ILL. WAVE.210

Metal structure mat gold

Borosilicate extraclear glass elements



C

Inspiration



GOLDEN CLOUD WALL

DESIGN | PAOLO CASTELLI



Muranese glass with
24Kt golden leaf powder



Metal Finish
Matt Gold

Preziosa lampada a parete interamente realizzata a mano secondo le più antiche tradizioni muranesi. L'elemento, realizzato in vetro di Murano con un triplo passaggio di foglia d'oro 24Kt, è agganciato a un corpo metallico in finitura oro opaco che alloggia al suo interno la sorgente led e il proprio driver.

Precious wall lamp entirely handmade according to the most ancient Murano traditions. The element, made of Murano glass with a triple passage of 24Kt gold leaf, is hanged to a metal body in matt gold finish which hosts the LED source and its driver inside.

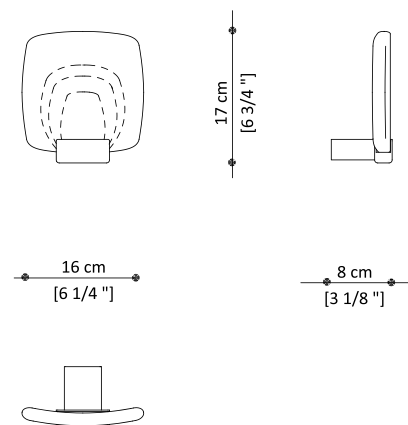

TECHNICAL SHEET
GOLDEN CLOUD WALL
Light source: LED
Total power: 3W
Voltage: 220-240 V
Rated luminous flux: 5000 Lm
Colour temperature: 2700° K
Colour rendering index: Ra>80
Dimmer function: No
Weight: Kg
Package size:
Package weight:
Package volume:

GOLDEN CLOUD WALL | ILL. GOLD.500

Glass lampshade - Muranese glass with 24Kt golden leaf powder
Metal body in matt gold finish



C

Inspiration

C

GOLDEN DISC WALL

DESIGN | PAOLO CASTELLI



Bovine Leather
Col. 634 Oasi



Muranese glass with
24KT golden leaf powder



Metal Finish
Matt Gold

Preziosa lampada a parete interamente realizzata a mano secondo le più antiche tradizioni muranesi. L'elemento, realizzato in vetro di Murano con un triplo passaggio di foglia d'oro 24Kt, è agganciato a un corpo metallico in finitura oro opaco che alloggia al suo interno la sorgente led e il proprio driver.

Precious wall lamp entirely handmade according to the most ancient Murano traditions. The element, made of Murano glass with a triple passage of 24Kt gold leaf, is hanged to a metal body in matt gold finish which hosts the LED source and its driver inside.

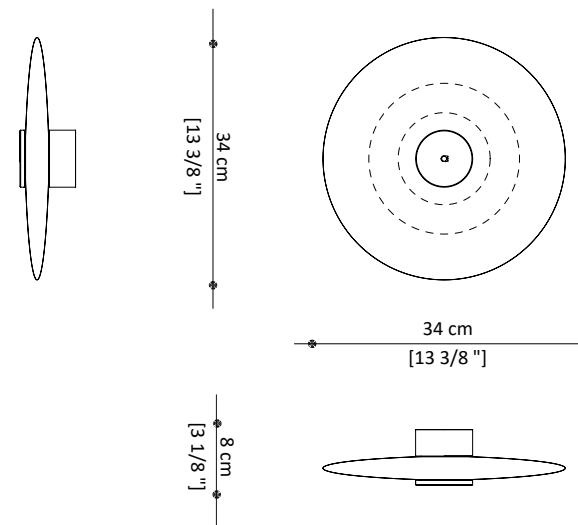

TECHNICAL SHEET
GOLDEN DISC WALL
Light source: LED
Total power: 3W
Voltage: 220-240 V
Rated luminous flux: 5000 Lm
Colour temperature: 2700° K
Colour rendering index: Ra>80
Dimmer function: No
Weight: Kg
Package size:
Package weight:
Package volume:

GOLDEN DISC WALL | ILL.: DISC.500

Metal disc finished matt-gold
Muranese glass with 24KT golden leaf powder



C



Inspiration

LABILIS WALL

DESIGN | PAOLO CASTELLI



 Metal Black
Matt varnished

 Metal Finish
Matt Bronzed
Brass

Tre anelli di diverso diametro installabili a parete singolarmente o in composizione libera. L'anello in metallo è finitura nero opaco con diffusore di luce led in polycarbonato opalino bianco perimetrale. Ogni anello è fissato a parete da un cilindro metallico in finitura bronzo ottone opaco e da due distanziatori in metallo finitura nero opaco. Alimentatore remoto. Optionals su richiesta: anelli dimmerabili.

Three rings of different diameters that can be installed on the wall individually or in random composition. The metal ring has a matte black finish with a white opal polycarbonate LED light diffuser around the perimeter. Each ring is fixed to the wall by a metal cylinder in matt brass bronze finish and by two metal spacers in matt black finish. Remote power supply. Optionals on request: dimmable rings.



RING Ø27

TECHNICAL SHEET LABILIS Ø27
Light source: Strip Led 140 Led/m
Total power: 7,3W - Strip led 14,4W/m
Voltage: 230 V
Rated luminous flux strip led: 1092 Lm
Colour temperature: 2700°K
Colour rendering index: 90
Dimmer function: Yes
Weight:

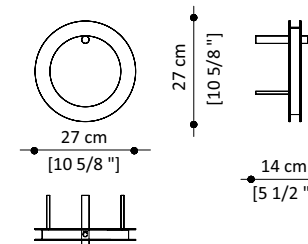

WALL RING Ø27 | ILL.LABI.530

1 ring Ø27 in metal matt black varnished. Metal cylinder in matt bronzed brass
Remote drivers

RING Ø43

TECHNICAL SHEET LABILIS Ø43
Light source: Strip Led 140 Led/m
Total power: 9,7W - Strip led 14,4W/m
Voltage: 230 V
Rated luminous flux strip led: 1755 Lm
Colour temperature: 2700°K
Colour rendering index: 90
Dimmer function: Yes
Weight:

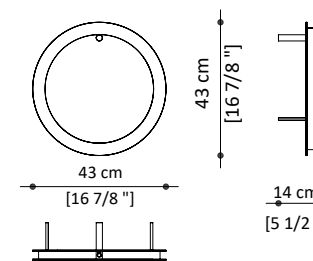

WALL RING Ø43 | ILL.LABI.520

1 ring Ø43 in metal matt black varnished. Metal cylinder in matt bronzed brass
Remote drivers

RING Ø70

TECHNICAL SHEET LABILIS Ø70
Light source: Strip Led 140 Led/m
Total power: 13,6W - Strip led 14,4W/m
Voltage: 230 V
Rated luminous flux strip led: 2857 Lm
Colour temperature: 2700°K
Colour rendering index: 90
Dimmer function: Yes
Weight:

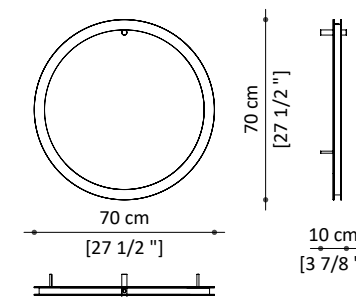

WALL RING Ø70 | ILL.LABI.510

1 ring Ø70 in metal matt black varnished. Metal cylinder in matt bronzed brass
Remote drivers



C



Inspiration



JOY WALL

DESIGN | VITTORIO PARADISO



 Murano Glass
Amaranth

 Matt
Brass

La composizione Joy nasce dal tema di dare corpo alla luce. La lampada è composta da un anello in ottone, e sfere in vetro soffiato satinato bianco opaco (sfera grande) e rosso amaranth (sfera piccola) magicamente sospese all'interno della struttura metallica sottile.

Un gioco di masse e di traiettorie circolari genera un disegno bilanciato di dinamiche gravitazionali.

La luce emanata dalle sfere si diffonde sullo spazio circostante e irraggia il telaio. I riflessi dell'ottone contribuiscono a rendere l'atmosfera ancora più sofisticata e onirica.

Joy composition was born of the idea of giving form to light. The lamp is composed of a brass ring and spheres in hand-blown white satin glass (big sphere) and red see-through, (small sphere) magically suspended within a thin metal structure. The play of circular masses and trajectories generates a balanced design of gravitational dynamics.

The light from the sphere is diffused into the surrounding space, illuminating the frame. The reflections of the brass render the luminous field visible by its aura.

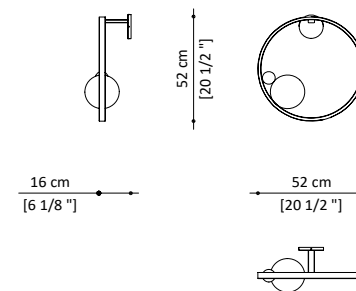

TECHNICAL SHEET

JOY WALL

Light source: LED

Total power: 1.9 W

Voltage: 220-240 V

Rated luminous flux: 204 Lm

Colour temperature: 2700° K

Colour rendering index: Ra>80

Dimmer function: No

Weight: Kg 10

Package size: 72 x 75 x 45 cm

Package weight: Kg 30

Package volume: Kg 0,25

JOY WALL | ILL. JOYL.500

3 ceiling canopies

Matt brass rings

Lamp shades in in hand-blown white satin glass.

Decorative glass sphere made in Murano glass col. Amaranth



CE



Inspiration



KALI' WALL LAMP

DESIGN | PAOLO CASTELLI

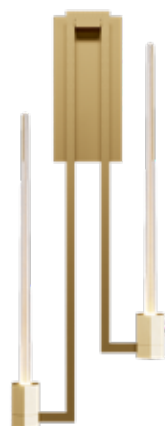

Metal Finish
Matt Gold



Muranese glass with
24KTgolden leaf powder

Kali vanta una lavorazione creata interamente sulla isola di Murano da storici artigiani. Della linea fa parte anche questa versione applique, realizzata con due bracci in metallo finitura oro opaco che sorreggono elementi in vetro di Murano con foglia d'oro 24 KT all'interno, in dispersione.

Kali is the result of an artisan handcraft totally made in Murano island. Wall version of Kali chandelier is also part of this collection. It is realised with a metal hand with mat gold finish bearing two Murano glass elements enclosing 24 KT golden leaf.

KALI' WALL

TECHNICAL SHEET

KALI' WALL

Light source: 2 spot led x 2 W
Total power: 4W
Voltage: 230 V
Rated luminous flux: 300 Lm
Colour temperature: 3000° K
Colour rendering index: Ra80
Dimmer function: No
Weight: Kg 8
Package size: 80 x 40 x 40 cm
Package weight: Kg 15

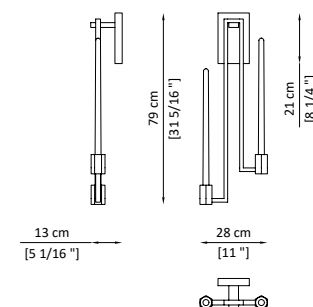

KALI' WALL | ILL. KALI.500

Metal structure mat gold
Muranese glass with 24KTgolden leaf powder

KALI' WALL SINGLE

TECHNICAL SHEET

KALI' WALL SINGLE

Light source: 2 spot led
Total power: 2W
Voltage: 230 V
Rated luminous flux: 150 Lm
Colour temperature: 3000° K
Colour rendering index: Ra80
Dimmer function: No
Weight: Kg 4
Package size: 40 x 40 x 40 cm
Package weight: Kg 10

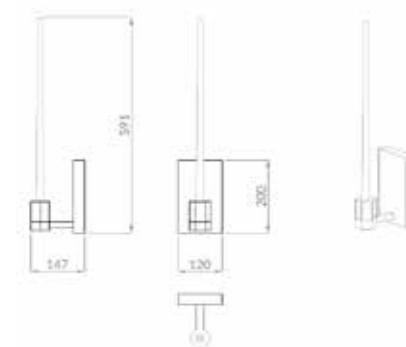

KALI' WALL SINGLE | ILL. KALI.510

Metal structure mat gold
Muranese glass with 24KTgolden leaf powder

Inspiration



FAIR LIGHT

DESIGN | PAOLO CASTELLI



Metal Finish
Matt Bronzed
Brass



Metal Painting
Black Matt

Fair Light è un corpo illuminante da parete costituito da un doppio binario di tubolari in metallo finitura nero opaco con diffusore in policarbonato opalino. La struttura di ancoraggio alla parete, che incorpora il driver, è in metallo finitura bronzo ottone opaco. L'apparecchio può essere montato sia in verticale che in orizzontale garantendo alla sorgente luminosa lineare un'ampia capacità di espressione, fornendo allo spazio energia e carattere.

Fair Light is a wall light fitting consisting of a double track made of black matt metal tubular elements with opal polycarbonate diffuser. The structure that anchors it to the wall incorporates the driver and is made of matt bronzed brass finished metal. The light can be fitted vertically or horizontally, guaranteeing the linear light source a broad capacity of expression, conveying energy and character to the room.

L60

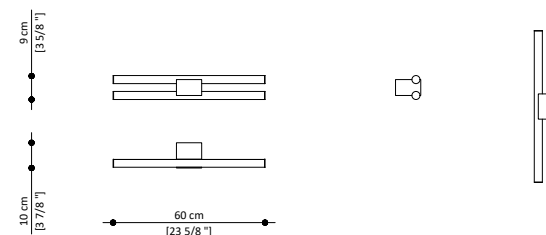

L60 | ILL.FAIR.510

Metal elements black matt finished
Details in metal matt bronzed brass finish

L110

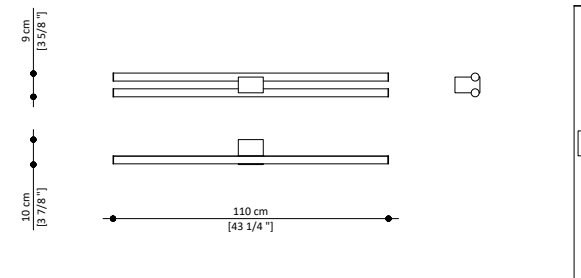

L110 | ILL.FAIR.520

Metal elements black matt finished
Details in metal matt bronzed brass finish

Inspiration

MY LAMP WALL

DESIGN | PAOLO CASTELLI



Metal Finish
Matt Gold

My Lamp Wall è una raffinata ed elegante lampada a parete che completa la collezione My Lamp. Si compone di un raffinato bouquet di tubi realizzati in vetro borosilicato veneziano e raccolti in una fascia metallica con finitura oro opaco.

My Lamp Wall is a stylish and elegant wall lamp that completes the My Lamp collection. It comprises a significant "bouquet" of venetian borosilicate glass tubes bound together by a metal band with a unique finish mat gold.



SMALL

TECHNICAL SHEET

MY LAMP WALL

Light source: LED

Total power: 15W

Voltage: 100-240V

Rated luminous flux: 1300 Lm

Colour temperature: 2700° K

Colour rendering index: Ra>80

Dimmer function: No

Weight: Kg 4

Package size: 130 x 30 x 50 cm

Package weight: Kg 15

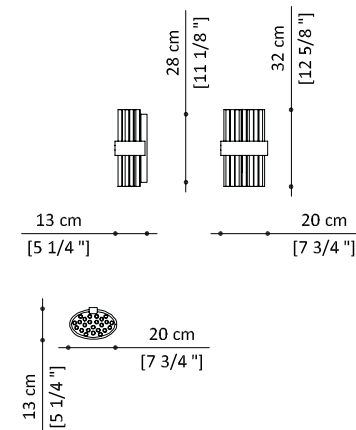

SMALL | ILL.MYLA.510

Mat gold finish

BIG

TECHNICAL SHEET

MY LAMP WALL BIG

Light source: Strip LED 15 W/M

Total power: 52W

Voltage: 220-240V

Rated luminous flux: 4760 Lm

Colour temperature: 2700° K

Colour rendering index: Ra>80

Dimmer function: No

Weight: Kg 17

Package size: 200 x 77 x 48 cm

Package weight: Kg 65

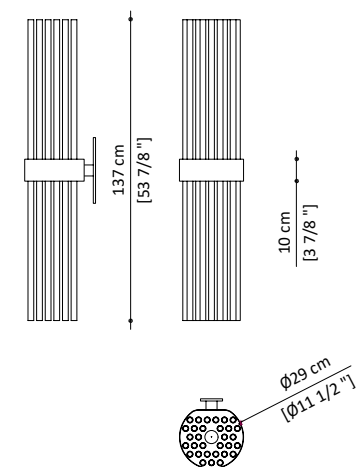

BIG | ILL.MYLA.520

Mat gold finish



C



Inspiration

ANODINE WALL

DESIGN | PAOLO CASTELLI



Metal Finish
Matt Gold

Anodine Wall è una graziosa lampada a parete che trasforma la luce in un dipinto attraverso il richiamo al concetto di "forma non forma" stilizzata della luce, arricchendo con una nota artistica d'eccellenza l'ambiente. La composizione consta di 11 elementi, ognuno dei quali è a forma di foglia in metallo, realizzato asimmetricamente a mano da esperti artigiani con finitura oro satinato o nero opaco. Nel modulo fisso a 8 elementi, 3 sono dotati di Led da 2W ognuno. La composizione è completata da 3 elementi singoli, da disporre a piacere per creare infinite combinazioni. La preziosità della lavorazione artigianale rende ogni pezzo della collezione unico nel suo genere.

Anodine Wall is a delicate wall lamp that transforms light into a painting evoking the concept of "shape non-shape" of the light, which adds an artistic touch to the ambience. It comprises 11 shiny metal leaves, all asymmetrical and hand-made by expert artisans, with a matt finish gold or black. In the fixed eight-element module, three leaves are lighted by 2W LED each. The composition is completed by 3 single elements, to be installed by choice in order to create endless combinations. Thanks to hand-made manufacturing techniques, each piece of the collection is unique.

C

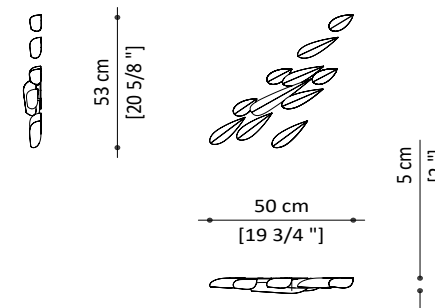

TECHNICAL SHEET

ANODINE WALL

Light source: Power LED COB

Total power: 11 W

Voltage: 220 - 240 V

Rated luminous flux: 1200 Lm

Colour temperature: 3000 °K

Colour rendering index: Ra80

Dimmer function: No

Weight: Kg 0,197

Package size: 72 x 52 x 68 cm

Package weight: Kg 13

Package volume: m³ 0,09

ANODINE WALL | ILL.ANOD.510

Mat gold finish



◀ Foglie realizzate
asimmetricamente a mano da
esperti artigiani.

Handcrafted asymmetrical
metal leaves.

Inspiration



CIRCLE LAMP

WALL LAMP

DESIGN | PAOLO CASTELLI



Metal Finish
Polished
Gold



Metal Finish
Varnished
Bronze



Metal Finish
Varnished
Ivory



Metal Finish
Varnished
Blue Grey

Una lampada decorativa da parete dalle dimensioni importanti ispirata alle linee morbide degli anni '40. Circle Lamp è realizzata attraverso un grande disco leggermente concavo in metallo martellato a mano e smaltato a specchio in diversi colori sul quale poggia al centro, come una goccia, una mezza sfera in metallo specchiato finitura oro lucido. Ogni pezzo della collezione è unico grazie alla preziosa lavorazione a mano.

A remarkable size decorative wall lamp, inspired by the soft lines of the 1940s. Circle Lamp consists of a slightly concave disc made of hand-hammered metal shiny gold and mirror glazed in various colors, on which a half sphere in reflective material sits like a drop. Thanks to hand-made manufacturing techniques, each piece of the collection is unique.

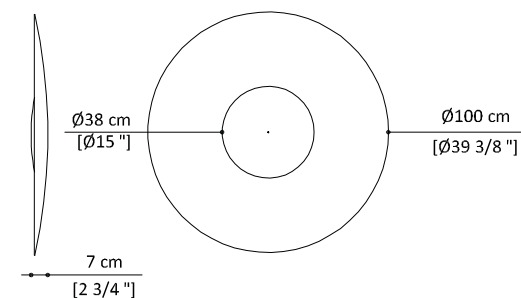

TECHNICAL SHEET

CIRCLE LAMP

Light source: Strip LED 8 W/M

Total power: 7,2W

Voltage: 230V

Rated luminous flux: 585 Lm

Colour temperature: 2700° K

Colour rendering index: Ra85

Dimmer function: No

Weight: Kg 15

Package size: 118 x 118 x 38 cm

Package weight: Kg 50

CIRCLE LAMP | ILL. CIRC. 500

Mat varnished disc with polished gold diffuser

Available colours: light blue Tiffany Ral 6034, Ivory Ral 9010, Bronze, Bluegrey Ral 5014



◀ **Grande disco leggermente concavo in metallo battuto a mano.**

Large disc slightly concave made of metal hammered by hand.

ANODINE CIRCLE LIGHT

DESIGN | PAOLO CASTELLI

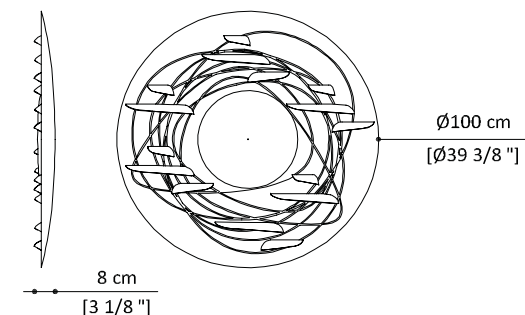

TECHNICAL SHEET

ANODINE CIRCLE LIGHT

Light source: Strip LED 8 W/M + LED COB 36 W

Total power: 43,2W

Voltage: 115 - 230 V

Rated luminous flux: 4785 Lm

Colour temperature: 2700° K

Colour rendering index: Ra80/85

Dimmer function: No

Weight: Kg 17

Package size: 118 x 118 x 38 cm

Package weight: Kg 52

 Metal Finish
Matt Gold

 Metal Finish
Varnished
Grey

 Metal Finish
Polished Gold

Anodine Circle Light di giorno è una scultura che riflette le dinamiche della luce naturale. Una lampada dal forte rimando artistico che bene si adatta agli ambienti dalla ricercata personalità. Si compone di tanti elementi luminosi in metallo con elegante finitura oro opaco satinato verniciata artigianalmente, legati tra di loro da un filo d'acciaio che fluttuano attorno alla lente centrale realizzata in metallo specchiato finitura oro lucido.

During the day, Anodine Circle Light is a sculpture that reflects the dynamics of natural light. A lamp with a strong artistic personality that suits spaces with a defined character. It comprises metal elements with an elegant artisanal painting matt gold finish, bound together with a steel wire, that fluctuate around the central structure made of mirror polished metal with a polished gold finish.

ANODINE CIRCLE LIGHT | ILL. ANOD.500

Grey mat varnished plate with inner polished bronzed element
Details in mat gold finish



◀ Foglie realizzate
asimmetricamente a mano da
esperti artigiani.

Handcrafted asymmetrical
metal leaves.

Inspiration



GALAXY WALL LAMP

DESIGN | PAOLO CASTELLI



Metal Finish
Matt Bronzed Brass



Metal Finish
Polished Gold

Galaxy è una lampada da parete che con le sue forme e riflessi diventa una vera e propria scultura. E' composta da lenti convesse in finitura oro lucido, abbinata a dischi in metallo finitura bronzo ottone opaco. Le superfici lisce e convesse donano dinamicità allo spazio.

Galaxy is a wall lamp with shapes and reflexes that almost turns it into a sculpture. It comprises a number of convex metal elements, with gold, shiny finish that reflect different tones of light combined with metal discs matt bronzed brass. Smooth and convex surfaces bring dynamism to the space.

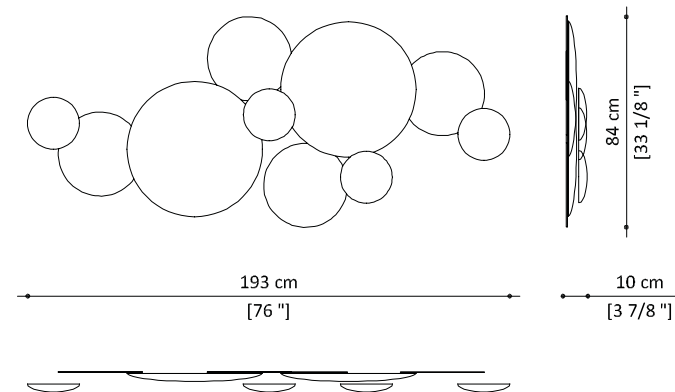

TECHNICAL SHEET

GALAXY

Light source: n. 2 LED modules 22W - n. 4 LED modules 11W

Total power: 88W

Voltage: 230V

Rated luminous flux: 4880 Lm

Colour temperature: 2700° K

Colour rendering index: Ra85

Dimmer function: No

Weight: Kg 22

Package size: 108 x 67 x 61 cm

Package weight: Kg 67

GALAXY | ILL.GALA.500

Matt polished gold lens
Matt bronzed brass discs



CE



◀ **Galvanica: prezioso processo di trattamento dell'ottone in grado di conferire allo stesso un'inaspettata tridimensionalità.**

Galvanic process: galvanic bath which gives to brass precious three-dimensional effect.

Inspiration

SORELUNA LAMP

DESIGN | PAOLO CASTELLI

CE



Metal Finish
Matt Gold



Marble
Noir Saint
Laurent

Lampada ancorata a soffitto composta da un cavo tirante centrale e contrappeso a terra realizzato in marmo Noir Saint Laurent in finitura lucida. Il cavo tirante centrale monta tre lampade coniche realizzate in metallo, con finitura oro opaco ed emissione luminosa con piastrine led circolari. Il rosone a soffitto è sempre di forma conica, in metallo finitura oro opaco.

Lamp anchored to the ceiling consisting of a central tie-rod cable and ground counterweight made of Noir Saint Laurent marble in a glossy finish. The central pull cable mounts three conical lamps made of metal, with a matt gold finish and light emission with circular LED plates. The ceiling rose is always conical in shape, in metal with a matt gold finish.

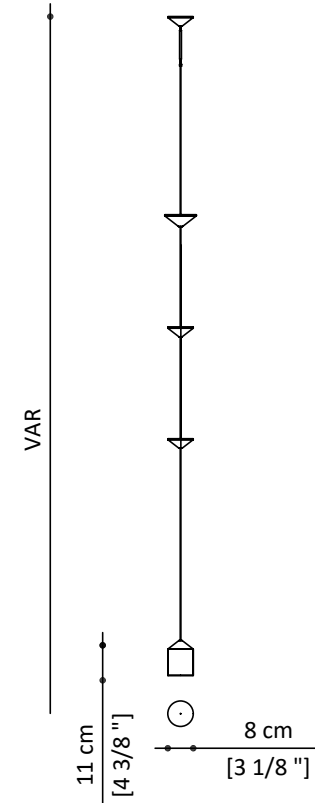

TECHNICAL SHEET

SORELUNA

Light source:

Total power:

Voltage:

Rated luminous flux:

Colour temperature:

Colour rendering index:

Dimmer function:

Weight:

Package size:

Package weight:

SORELUNA | ILL.SORE.100

Mat gold finish caps - metal cable
Marble basement

On request

C



Inspiration

C

MY LAMP FLOOR LAMP

DESIGN | PAOLO CASTELLI

CE



Metal Finish
Matt Gold

My Lamp Floor è una lampada da terra, elegante nelle forme, che dona una luce ed un'atmosfera calda all'ambiente in cui viene inserito. Da solo o in coppia, per creare una perfetta simmetria, arricchisce e caratterizza ogni possibile situazione abitativa. È realizzato con una base e struttura in metallo, rifinita in finitura oro opaco e tubi cilindrici aperti realizzati in vetro borosilicato veneziano.

My Lamp Floor is a standing lamp, boasting an elegant shape that brings light and a warm atmosphere to any space. Single or in a pair, to create a perfect symmetry, enriches and adds character to any room. It features a metal base and a structure with matt gold finish and open cylindrical tubes made from venetian borosilicate glass.

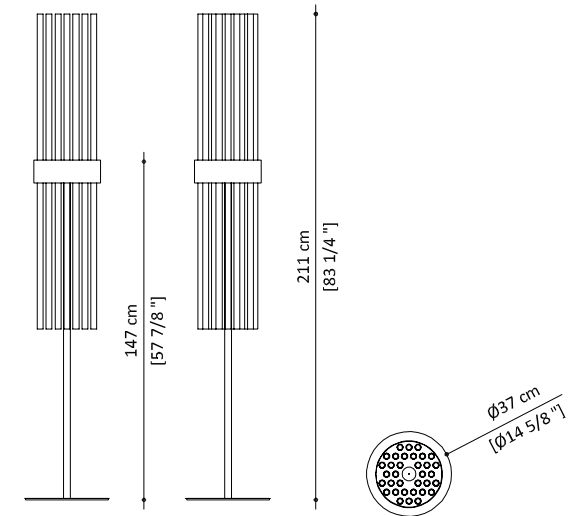

TECHNICAL SHEET

MYLAMP FLOOR

Light source: 4 LED modules

Total power: 35W

Voltage: 240 V

Rated luminous flux: 2600 Lm

Colour temperature: 2700° K

Colour rendering index: Ra80

Dimmer function: No

Weight: Kg 39

Package size: 160 x 76 x 60 cm

Package weight: Kg 78

MY LAMP FLOOR | ILL.MYLA.100

Mat gold finish



Inspiration



MY LAMP TABLE LAMP

DESIGN | PAOLO CASTELLI



Metal Finish
Matt Gold

My lamp table è una graziosa ed elegante lampada da tavolo, ideale per studi, salotti e zona notte, composta da una struttura metallica trattata in finitura oro opaco che regge un piccolo bouquet di tubi realizzati in vetro borosilicato veneziano.

My lamp table is a visually pleasing and elegant desk lamp, ideal for studios, lounges and bedrooms. It comprises a metal structure with a matt gold finish that supports a "bouquet" of tubes made from venetian borosilicate glass.

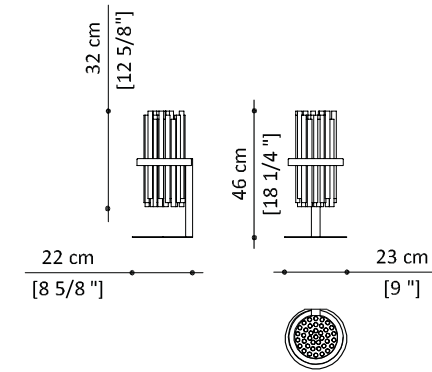

TECHNICAL SHEET

MYLAMP TABLE

Light source: Strip LED

Total power: 13W

Voltage: 240 V

Rated luminous flux: 860 Lm

Colour temperature: 2700° K

Colour rendering index: Ra80

Dimmer function: No

Weight: Kg 4

Package size: 30 x 30 x 50 cm

Package weight: Kg 15

MY LAMP TABLE | ILL.MYLA.400

Matt gold finish



C



Inspiration



ANODINE FLOOR

DESIGN | PAOLO CASTELLI



Metal Finish
Matt Gold



Metal Finish
Polished Brass

Anodine Floor è una lampada da terra che trasforma la luce in una scultura attraverso il richiamo al concetto di "forma non forma" stilizzata della luce, arricchendo con una nota artistica d'eccellenza l'ambiente. È composta da 13 lunghi steli in ottone lucido ancorati ad una base metallica quadrata, alcuni vengono decorati da foglie in metallo realizzate asimmetricamente a mano da esperti artigiani e finite con finitura oro opaco satinato. La base è in finitura oro opaco satinato. Perfetta in coppia per creare la giusta simmetria nello spazio. La preziosità della lavorazione artigianale rende ogni pezzo della collezione unico nel suo genere.

Anodine Floor is a free-standing lamp that transforms light into a sculpture evoking the concept of "shape non-shape" of the light, which adds an artistic touch to the ambience. It comprises 13 shiny brass stems anchored to a square metal base finished "mat gold", some decorated with metal leaves, all asymmetrical and hand-made by expert artisans, with a matt gold satin finish. Perfect as a couple to create the right symmetry in the room. Thanks to hand-made manufacturing techniques, each piece of the collection is unique.

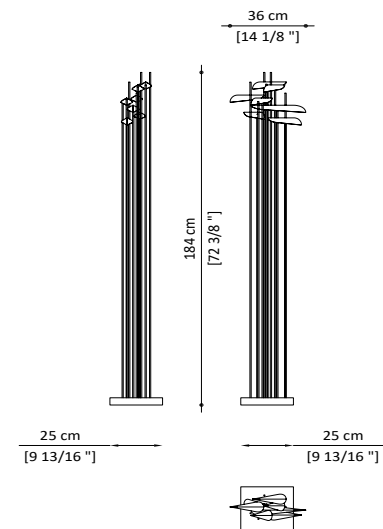

TECHNICAL SHEET

ANODINE FLOOR

Light source: Power LED COB

Total power: 24,5 W

Voltage: 54 V

Rated luminous flux: 2765 Lm

Colour temperature: 3000° K

Colour rendering index: Ra85

Dimmer function: No

Weight: Kg 10

Package size: 200 x 52 x 52 cm

Package weight: Kg 45

ANODINE FLOOR | ILL.ANOD.100

13 lighting elements

Lamp shades and base in matt gold finish - Polished brass stems



CE



ANODINE TABLE & MINI

DESIGN | PAOLO CASTELLI

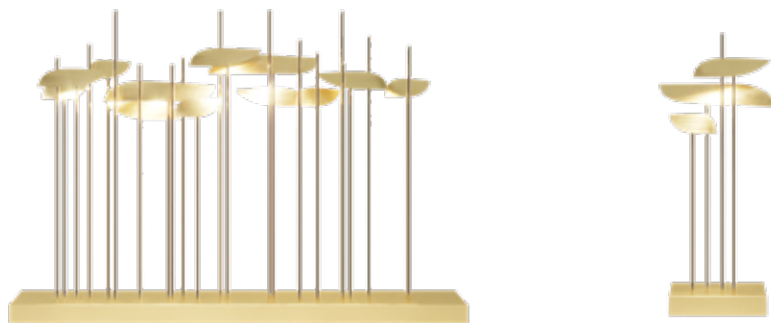

Metal Finish
Matt Gold



Metal Finish
Polished Brass

Anodine Table è una graziosa lampada da tavolo. La preziosità della lavorazione artigianale rende ogni pezzo della collezione unico nel suo genere.

ANODINE TABLE: È composta da 26 steli in ottone lucido ancorati ad una base metallica con finitura oro opaco satinato verniciata artigianalmente, che vengono decorati da foglie in metallo, realizzate asimmetricamente a mano da esperti artigiani e finite con finitura oro satinato.

ANODINE MINI: È composta da 3 steli in ottone lucido ancorati ad una base metallica con finitura oro opaco satinato, che vengono decorati da foglie in metallo realizzate asimmetricamente a mano da esperti artigiani con finitura oro opaco satinato verniciata artigianalmente.

Anodine table is a fair table lamp. Thanks to hand-made manufacturing techniques, each piece of the collection is unique.

ANODINE TABLE: It comprises 26 shiny brass stems anchored to a metal base with a matt gold satin artisanal painting finish, decorated with metal leaves, all asymmetrical and hand-made by expert artisans, with a matt gold finish.

ANODINE MINI: It comprises 3 shiny brass stems anchored to a metal base with a matt gold satin finish, decorated with metal leaves, all asymmetrical and hand-made by expert artisans, with a matt gold artisanal painting finish.

MINI

TECHNICAL SHEET

ANODINE MINI

Light source: Power LED COB
Total power: 10,5 W
Voltage: 120 V
Rated luminous flux: 1185 Lm
Colour temperature: 3000° K
Colour rendering index: Ra85
Dimmer function: No
Weight: Kg 3
Package size: 37 x 37 x 83 cm
Package weight: Kg 18

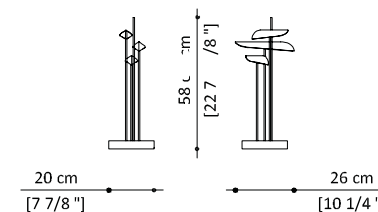

ANODINE MINI | ILL.ANOD.430

3 lighting elements

Lamp shades and base in matt gold finish - Polished brass stems

TABLE

TECHNICAL SHEET

ANODINE TABLE

Light source: Power LED COB
Total power: 13 x 3,15 W (41 W)
Voltage: 110 - 295 V
Rated luminous flux: 5135 Lm
Colour temperature: 3000° K
Colour rendering index: Ra85
Dimmer function: No
Weight: Kg 10
Package size: 117 x 37 x 97 cm
Package weight: Kg 56

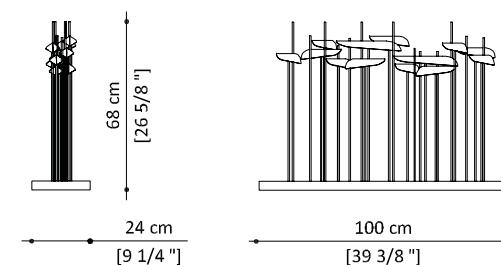

ANODINE TABLE | ILL.ANOD.410

13 lighting elements

Lamp shades and base in matt gold finish - Polished brass stems



CE



Inspiration



COLETTE HUGO

DESIGN | PAOLO CASTELLI



Fabric
Percale



Muranese glass with
24KTgolden leaf powder

Dalla maestria degli artigiani vetrai di Murano nasce questa amabile coppia di lampade da tavolo. Ne viene proposto un ensemble per enfatizzare la perfetta armonia di forma e stile, amabili tuttavia anche singolarmente per conferire un tocco sofisticato a qualsiasi tipo di ambientazione.

La base è a forma di goccia, realizzata in vetro di Murano con all'interno polvere d'oro 24 KT in sospensione, e paralume in tessuto percalle realizzato artigianalmente. Hugo, più compatta, ha una forma piena e morbida ed un cappello cilindrico, mentre Colette è slanciata e leggermente più alta, con un paralume rastremato.

Thanks to the Murano glass hand craftsmanship virtuosity, a lovely couple of table lamp has appeared. This ensemble emphasizes the perfect shape and style harmony that can be appreciated also in their singularity in order to give a sophisticated touch to every kind of set. The drop-shape base is made of Muranese glass enclosing a 24 KT golden leaf, the lampshade is in a hand made fabric percalle.

Hugo, more compact, has a full and soft shape and a cylindrical lampshade; otherwise, Colette is slim and a bit higher with a tapered lampshade.

COLETTE

TECHNICAL SHEET

COLETTE

Light source: E27 light bulb
Lamp socket: E27
Total power: 8 W
Voltage: 230 V
Rated luminous flux: 1055 lm
Colour temperature: 2700°K
Colour rendering index: Ra>80
Dimmer function: No
Weight: Kg 8
Package size: 55 x 55 x 45 cm (lampshade)
Package size: 40 x 40 x 60 cm (base)
Package weight: Kg 3 (lampshade)
Package weight: Kg 10 (base)

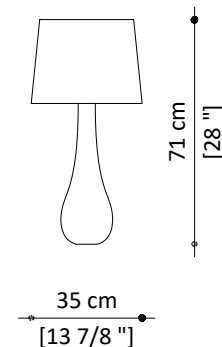

COLETTE | ILL. ALLU. 410

Muranese glass with 24KTgolden leaf powder - Percale fabric lampshade

HUGO

TECHNICAL SHEET

HUGO

Light source: E27 light bulb
Lamp socket: E27
Total power: 8 W
Voltage: 230 V
Rated luminous flux: 1055 lm
Colour temperature: 2700°K
Colour rendering index: Ra>80
Dimmer function: No
Weight: Kg 8
Package size: 55 x 55 x 45 cm (lampshade)
Package size: 50 x 50 x 50 cm (base)
Package weight: Kg 3 (lampshade)
Package weight: Kg 10 (base)

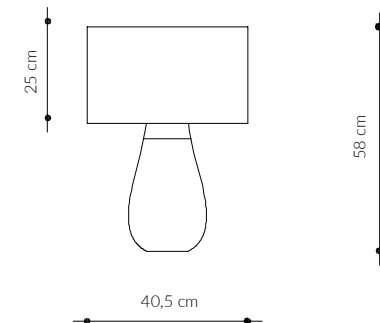

HUGO | ILL. ALLU. 420

Muranese glass with 24KTgolden leaf powder - Percale fabric lampshade



C



◀ Logo decorativo inciso manualmente da abili artigiani.

Decorative logo engraved by hand by expert artisans.

Inspiration



AMBRA LAMP

DESIGN | ILARIA BALDUINO SARTORI



Metal Finish
Matt Bronzed
Brass



Fabric
Blended
viscose

Ambra è l'abat-jour ideale per creare dei caldi ed eleganti punti luce in salotti, camere padronali e raffinate suite. Questa lampada è composta da un'asta in ottone con finitura bronzo ottone opaco nella quale sono inseriti e ruotano dischi in lucite alternati a metallo che creano un sofisticato gioco di trasparenze e riflessi di luci.

Ambra è completata nella parte superiore da un prezioso cappello in tessuto misto viscosa col. crema, impreziosito ai bordi da un'elegante passamaneria in tinta.

Ambra is the ideal table lamp to create warm and elegant lighting points in lounges, master bedrooms and elegant suites. It comprises a brass rod with a matt bronzed brass finish on which lucite rotating discs alternate with metal, creating a sophisticated transparency and light reflection.

Ambra is finished with an exquisite lampshade in viscose blended fabric col. cream, enriched at the edges with precious coordinated braid.

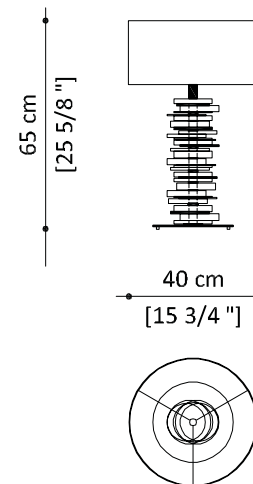

TECHNICAL SHEET

AMBRA

Light source: E27 light bulb

Lamp socket: 1 x E27

Total power: 9 W

Voltage: 230 V

Rated luminous flux: 1055 lm

Colour temperature: 2700° K

Colour rendering index: Ra>80

Dimmer function: No

Weight: Kg 16

Package size: 52 x 52 x 41 cm (lampshade)

Package size: 60 x 41 x 40 cm (base)

Package weight: Kg 5 (lampshade)

Package weight: Kg 20 (base)

AMBRA TABLE LAMP | ILL.AMBR.410

Metal and plexyglass with blended viscose fabric lampshade



◀ **Lucite: materiale molto diffuso nella realizzazione di gioielli e bijoux negli anni '30 e '40.**

Lucite: widespread material used for jewellery and bijoux in the '30s and '40s.

Inspiration



NETTUNO TABLE LAMP

DESIGN | VITTORIO PARADISO



Metal Finish
Matt Gold



Murano
Glass Pink



Fabric
Percale

Coppia di lampade da tavolo che completa la collezione Nettuno (tavolo, desk e coffee table). Il corpo in vetro scanalato a mano ha forma di parallelepipedo e viene presentato di colore e altezze diverse. Il corpo più slanciato è di colore rosa antico, mentre quello più compatto è di color pagliesco, entrambi reggono un portalamпада con due lampadine E27. Il paralume in tessuto percale color avorio, l'accensione a catenella e il cavo di alimentazione in tessuto color oro contribuiscono a creare una silhouette calda e sofisticata. Entrambi i modelli possono essere realizzati in color rosa antico o pagliesco.

È disponibile in due dimensioni.

Pair of table lamps that complete the Nettuno collection (table, desk and coffee table). The body in hand-grooved glass in the shape of a parallelepiped is presented in different colours and heights. The more slender body is in antique pink, while the more compact body is straw-coloured; both are fitted with a lamp holder for two E27 bulbs. The ivory-coloured percale fabric lampshade, the chain-style pull-cord and the gold-coloured fabric power supply cable contribute to creating a warm and sophisticated silhouette. Both lamps can be made in antique pink or straw-coloured glass.

It is available in two sizes.

SMALL

TECHNICAL SHEET
NETTUNO TABLE LAMP SMALL
Light source: E27 LED 2X
Total power: 5.5 W x 2
Voltage: 220 - 240 V
Rated luminous flux: 470 Lm
Colour temperature: 2700° K
Colour rendering index: Ra>80
Dimmer function: No
Weight: Kg 6
Package size base: 80 x 28 x 32 cm
Package weight base: Kg 7
Package volume: Kg 0,07
Package size lampshade: 49 x 47 x 45 cm
Package weight lampshade: Kg 2
Package volume: Kg 0,07

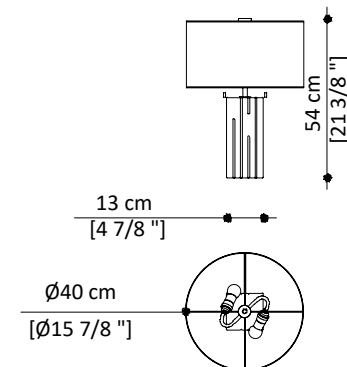

SMALL | ILL.NETT.420

Structure in hand-grooved glass antique pink or straw-coloured
Percale fabric lampshade

BIG

TECHNICAL SHEET
NETTUNO TABLE LAMP BIG
Light source: E27 LED 2X
Total power: 5.5 W x 2
Voltage: 220 - 240 V
Rated luminous flux: 470 Lm
Colour temperature: 2700° K
Colour rendering index: Ra>80
Dimmer function: No
Weight: Kg 6
Package size base: 80 x 28 x 32 cm
Package weight base: Kg 7
Package volume: Kg 0,07
Package size lampshade: 49 x 47 x 45 cm
Package weight lampshade: Kg 2
Package volume: Kg 0,07

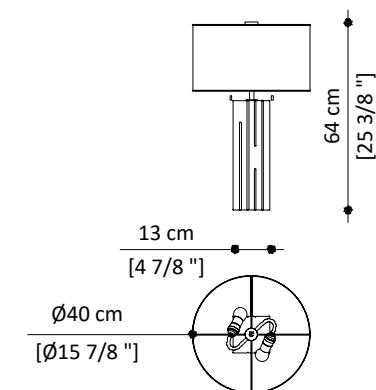

BIG | ILL.NETT.410

Structure in hand-grooved glass antique pink or straw-coloured
Percale fabric lampshade



C



◀ **Corpo parallelepipedo in vetro di Murano lavorato e scanalato a mano.**

A glass parallelepiped fluted by hand by Muranese artisans.

Inspiration

C

KALI' TABLE LAMP

DESIGN | PAOLO CASTELLI

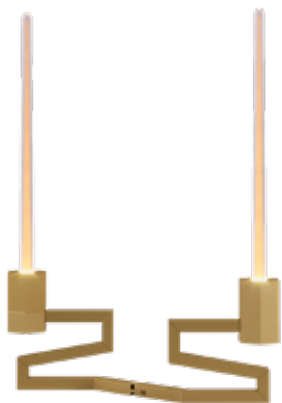

Satined
Brass



Muranese glass with
24KTgolden leaf powder

Kali vanta una lavorazione creata interamente sulla isola di Murano da storici artigiani.

Della linea fa parte anche questa versione da tavolo, realizzata con due bracci in ottone che sorreggono elementi in vetro di Murano con foglia d'oro 24 KT all'interno, in dispersione.

Kali is the result of an artisan handcraft totally made in Murano island.

Table version of Kali chandelier is also part of this collection. It is realised with a brass hand bearing two Murano glass elements enclosing 24 KT golden leaf.

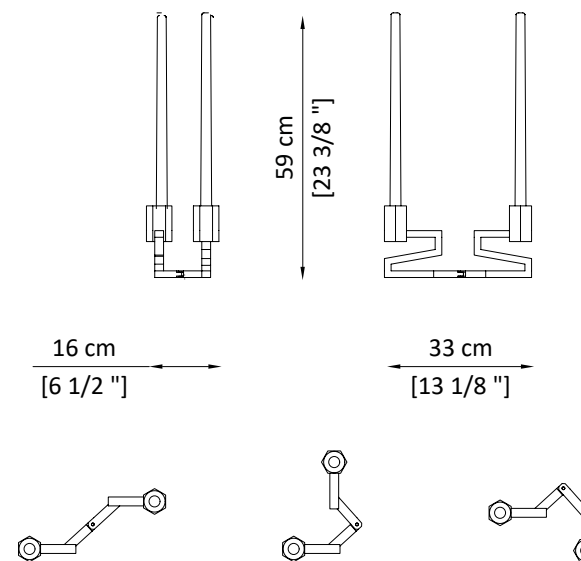

TECHNICAL SHEET

KALI' TABLE

Light source: 2 spot led x 2 W

Total power: 4W

Voltage: 230 V

Rated luminous flux: 300 Lm

Colour temperature: 3000° K

Colour rendering index: Ra80

Dimmer function: Yes

Weight: Kg 8

Package size: 80 x 40 x 40 cm

Package weight: Kg 15

KALI' TABLE | ILL. KALI.400

Satined brass structure

Muranese glass with 24KTgolden leaf powder



Inspiration



FOR HALL LAMP

DESIGN | PAOLO CASTELLI



Metal Finish
Matt Gold

Una colonna di luce dalle proporzioni regolari che vuole richiamare gli arredi anni '30 e '40 e che, con il suo sviluppo verticale, diventa quasi un elemento architettonico. For Hall Lamp si compone di una piantana a base cilindrica in ceramica artigianale piombata ed inserita all'interno di una struttura metallica quadrata in metallo con finitura oro opaco. Il paralume è realizzato in preziosa pergamena che si inserisce nella struttura stessa.

A column of light of regular proportions, recalling the furnishings of the 1930s and 1940s, this vertical floor lamp almost turns into an architectural element. For Hall Lamp comprises a stand with cylindrical ceramic base with a lead glaze, inserted in a square metal structure with galvanic matt gold finish. The precious parchment lampshade is inserted in the structure.

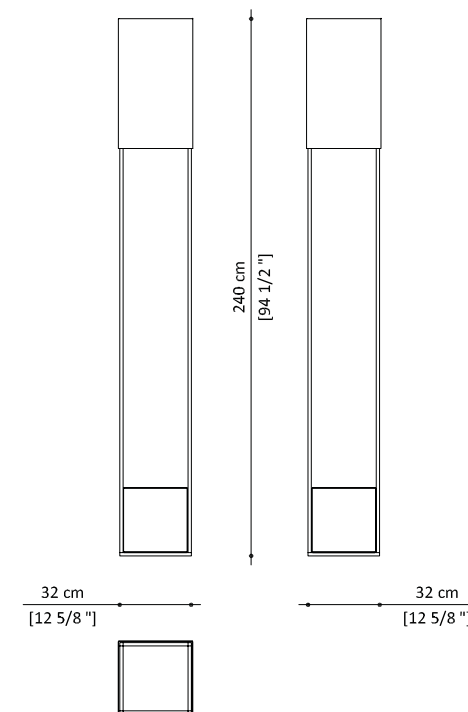

TECHNICAL SHEET FOR HALL LAMP

Light source: Lamp Holder 4 x E27(30 W max) +
1 X GU10 (35 W max)

Total power: 155W

Voltage: 230 V

Weight: Kg 52

Package size: 60 x 60 x 210 cm

Package weight: Kg 80

FOR HALL FLOOR LAMP | ILL.FORH.100

Metal frame matt gold finished- Paper lampshade

STANDARD SALES TERMS AND CONDITIONS

General Provisions

a) The Standard Sales Terms and Conditions (hereinafter referred to as the "Standard Terms and Conditions") form an integral part of the agreements entered into between Paolo Castelli S.p.a. (hereinafter referred to as "Paolo Castelli") and the Purchaser for the supply of products supplied and/or distributed by the above mentioned company (hereinafter the "Products").

(b) The Standard Terms and Conditions apply to all transactions entered into between Paolo Castelli and the Purchaser whether or not expressly referenced therein. Any terms or conditions different from those provided herein shall only take effect if confirmed in writing by Paolo Castelli. Paolo Castelli reserves the right to modify, supplement or amend the Standard Terms and Conditions, by attaching such changes to quotations or any written correspondence.

Quotations and orders

Customer's acceptance of the quotations submitted by Paolo Castelli - upon receipt of 50% deposit - is binding on the Customer and irrevocable. Upon receipt of such acceptance, Paolo Castelli will send the Customer an order confirmation expressly stating delivery method and the technical information necessary to deliver the goods (e.g. delivery addresses, delivery to the floor, time, contact persons and telephone number). Any quotations submitted by agents shall only be deemed to be valid and effective after they are confirmed in writing by Paolo Castelli. Any changes to or requests and integrations to quotations by agents or Customers shall be made in writing, and shall require a written confirmation by Paolo Castelli. Paolo Castelli disclaims any and all liabilities for possible errors or misunderstandings arising in connection with changes to orders placed verbally or over the telephone.

Prices and Payment Terms

Product Prices do not include VAT, which must be paid according to specific indications provided in the invoice.

Taxes, duties, shipping, insurance, installation and after-sales service are not included in the prices, unless quoted separately.

In addition to the other remedies allowed by applicable law or these General Terms and Conditions, Paolo Castelli reserves the right to charge late payment interests at the official interest rate set by the European Central Bank plus seven (7) points as of the day payment was due. Payments shall be made as follows: 50% down payment when quotation is signed; 50% balance shall be paid before Products are shipped. Any other conditions agreed upon shall require the written form. In the event of default or late payment after the term indicated by Paolo Castelli, even in part or limited to one price instalment, Paolo Castelli shall be entitled to terminate the agreement without further notice. All amounts paid up to that time shall be withheld by way of damage compensation.

Changes to orders

Any requests of changes deviating from the content of order confirmation may only be accepted if compatible with the production process and/or the process under way. If accepted, they may give rise to extra charges incurred in making such changes.

Orders - Customer's default

It is hereby expressly agreed that the Customer may not unilaterally terminate the order and/or the agreement. In the event after confirming an order Paolo Castelli becomes aware of detrimental events affecting the Purchaser such as protests, seizures, attachment, or it becomes known that the Purchaser is in financial difficulties, Paolo Castelli may, at its discretion, suspend order fulfilment and demand special guarantees, or terminate the agreement on grounds of Purchaser default under art. 1456 of the Italian Civil Code by written notice via registered mail with advice of receipt, fax or CEM.

Delivery and Delivery Terms

Unless otherwise agreed, delivery is ex works at Customer's risk. Notwithstanding the above, Paolo Castelli may charge an additional shipping fee to Customer on invoice. Partial deliveries are only allowed when agreed upon between the parties and any extra costs shall be borne by Customer. The delivery times indicated by Paolo Castelli are not binding and are computed in working days starting from receipt of the first down payment. In the event delivery is postponed through fault of the Customer and the Product needs to be kept in stock for more than 5 days after the agreed delivery date, any relating costs shall be charged to Customer and Paolo Castelli shall not be liable for any damage to and/or deterioration of the Product. Unless otherwise agreed, downloading and delivery to floor are at the Customer's expense. For any events outside the control of Paolo Castelli, such as orders of authorities, shortage of raw materials, riots of any kind and other force majeure events, Paolo Castelli shall deem itself to not be bound to any terms or commitments for the duration of the adverse event.

Installation

At Customer's request, installation may be performed by personnel appointed by Paolo Castelli, and any costs incurred for installers and the assistance of skilled personnel shall be at Customer's charge. Installation does not include any masonry work, plant installation, or any other work not expressly specified on order or anyway outside the scope of the supply.

Customer shall make available a suitable storage room for products and equipment. Paolo Castelli shall not be liable for faults or breakdown occurring during installation.

Responsibility:

Paolo Castelli does not respond to any damage to person or property caused by the incorrect installation of its lighting fixtures and furniture.

Warranty

It is the Customer's responsibility to check product compliance at the time of receipt and anyway before commissioning. Unless Customer claims a defect and informs the seller within eight days from discovering such defect, Customer's rights under applicable law shall become null and void. Failure to comply with payment terms and conditions on the part of the Purchaser shall make the warranty null and void.

Retention of title

Pursuant to articles 1523 and 1524 of the Italian Civil Code, the parties agree that the sales transaction is subject to retention of title in favour of the seller. The parties agree that the ownership of the Product is transferred to the Customer at the time the full price is settled, whereas possession and the associated risk to the Purchaser is transferred at the time the product is shipped to Customer. Court of jurisdiction: The agreement is governed by Italian law. Any dispute concerning the construction or performance of agreements between the parties shall be submitted to the Court of Bologna, that shall have sole jurisdiction.



PAOLO CASTELLI

La descrizione e le immagini dei prodotti del presente catalogo sono puramente indicative e non possono essere considerate vincolanti ai fini del loro utilizzo. Paolo Castelli S.p.A. si riserva di apportare ai prodotti le modifiche che ritiene più opportune, in qualsiasi momento e senza preavviso. I prodotti, di natura artigianale, possono presentare artefatti materici o irregolarità di lavorazione. Tali irregolarità sono da considerarsi parte integrante della struttura del prodotto stesso e garanzia della lavorazione interamente artigianale.

Per ulteriori informazioni sulle caratteristiche tecniche dei prodotti, invitiamo a consultare il sito www.paolocastelli.com dove troverete l'elenco dei contatti a cui rivolgervi.

Descriptions and pictures of the products included in the present catalogue are purely indicative and cannot be considered binding for their final use. Paolo Castelli S.p.A. reserves itself the right to modify its own products without any prior notification. The handmade artisan production can present irregularities due to the manufacturing. These irregularities must be considered essential part of the product itself and guarantee of entirely handcrafted manufacturing. For any further technical information on the products, please visit

www.paolocastelli.com where you can find all the contacts you can address to.



PAOLO CASTELLI

BOLOGNA

Contract Office & Showroom

MILAN

Contract Office & Showroom

PARIS

Contract Office & Showroom

LONDON

Contract Office

CARRARA

Marine Division

HEADQUARTER VIA I° MAGGIO, 93 | 40064 OZZANO DELL'EMILIA | BOLOGNA - ITALY | TEL. +39 051 4695511 | info@paolocastellispa.com | www.paolocastelli.com