

SUPERMOODBOARD



PAOLO CASTELLI



PAOLO CASTELLI signs SUPERMOODBOARD

PAOLO CASTELLI è un'azienda bolognese che opera in quattro diversi settori tra design e architettura.

DESIGN: si articola in 3 collezioni di arredo e illuminazione High-end.

Inspiration propone rimandi alla bellezza dei mitici anni Trenta, che hanno guidato il design.

Greenkiss: sapore francese, e tecniche e finiture eco-sostenibili che, grazie ai nostri artigiani, rendono i prodotti green.

Morandi Collection: direttamente dalle tele del grande maestro Giorgio Morandi, prendono forma oggetti raffinati ispirati dal suo vivere quotidiano.

CONTRACT: un team di professionisti in grado di sviluppare progetti e renderli reali con finiture e soluzioni tecniche di altissimo livello. Organizzazione, qualità e value engineering sono le nostre parole chiave.

MARINE: architetti e ingegneri navali, che dalla Versilia operano da 11 anni sui maggiori cantieri navali italiani realizzando e portando a termine progetti sfidanti.

PRODUZIONE PER TERZI: con la prototipizzazione rapida, abbiamo conquistato le principali case di moda Italiane e Francesi, fornendo loro prodotti delle nostre collezioni o sviluppando i nuovi concept d'arredo.

I prodotti Paolo Castelli privilegiano materiali biologici e sono frutto di una particolare ricerca nel campo dell'ecosostenibilità.

PAOLO CASTELLI is a Bolognese company that operates in four different sectors between design and architecture.

DESIGN COLLECTION: is divided into 3 high-end furniture & lighting lines.

Inspiration: everything comes from here, references to the beauty of the legendary Thirties, which still are considered the point of reference in design, create sophisticated lamps and furnishings;

Greenkiss: French flavor, bio-sustainable techniques and finishes that, thanks to our artisans, make the products green and eco-friendly;

Morandi Collection: directly from the paintings of the great master Giorgio Morandi, refined objects took shape from Maestro's daily life.

CONTRACT: a team of professionals able to develop projects and make them real with finishes and technical solutions of the highest level. Organization, quality and value engineering are our keywords.

MARINE: naval architects and engineers, based in Versilia, who have been working in the naval sector for 11 years, creating and completing challenging projects.

THIRD PARTIES PRODUCTION: with rapid prototyping, we have conquered the main Italian and French fashion brands, providing them with products from our collections or developing new interior concepts.

For our products we prefer organic materials and they are the result of particular research in the environmental sustainability field.

PAOLO CASTELLI

Inspiration

Fine furniture and lighting

GREENKISS

Eco-responsible furniture



BOLOGNA
Headquarter
Via I° Maggio, 93
40064 Ozzano Dell'Emilia (BO)
Italy
info@paolocastellipa.com

MILANO
Showroom
Via San Carpoforo
20121 Milan
Italy
milano@paolocastellipa.com

PARIS
Showroom
266 Boulevard Saint Germain
75007 Paris
France
france@paolocastellipa.com



Comet
Floor & table Lamp

U
Chair

Lens
Coffee tables





Comet
Floor & table Lamp



U
Chair



Lens
Coffee tables

Comet

Table & floor lamp

DIM.
 Table lamp L/W 46 x P/D 10 x H 54 cm
 Floor lamp L/W 75 x P/D 10 x H 139 cm

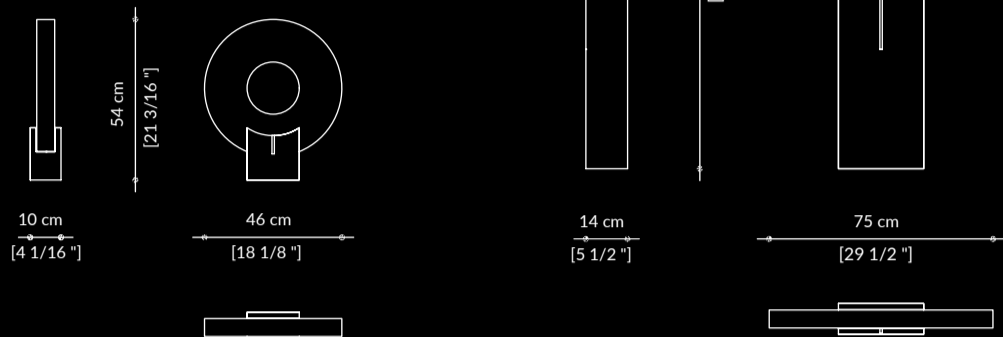

TABLE

FLOOR

Lampade totemiche - da terra e da tavolo - realizzate con basamento in noce Canaletto oliato o in metallo finitura zinco acidato, impreziosito da un inserto in ottone satinato opaco. Paralume a forma di anello realizzato in tessuto naturale col. avorio.

Totem lamps - floor and table version - made with base in oiled Canaletto walnut or in metal with acid-etched zinc finish, embellished with an insert in matt satin brass. Ring-shaped lampshade made of natural fabric col. ivory.

U

Chair

DIM.
 Chair L/W 54 x P/D 57 x H 83 cm; H seat 48 cm
 Lounge L/W 65 x P/D 67 x H 76 cm; H seat 48 cm

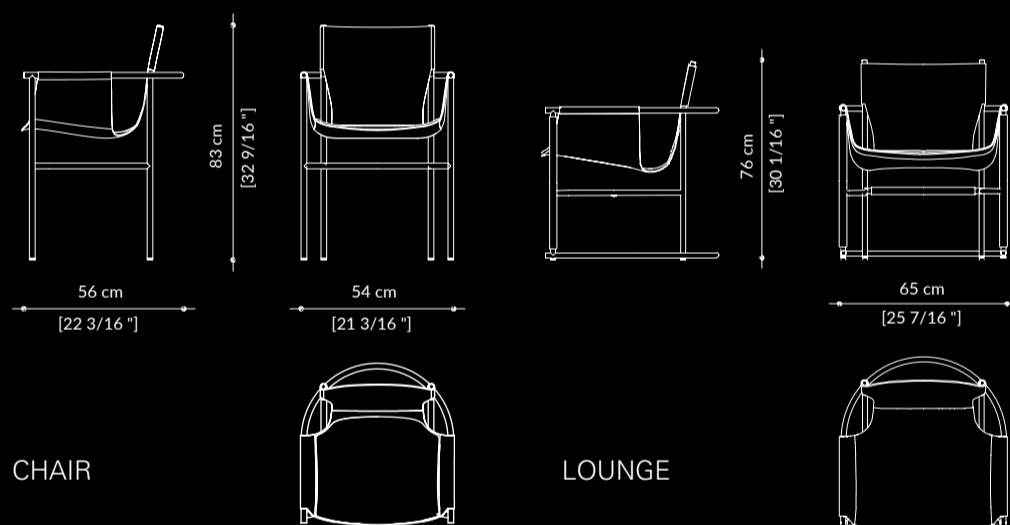

CHAIR

LOUNGE

Raffinata seduta e poltroncina la cui forma invitante è definita da una profondità accentuata e da un fronte leggermente inclinato. La struttura, che avvolge elegantemente il corpo, è disponibile in finitura bronzo ottone opaco con rivestimento in cuoio col. testa di moro, oppure in metallo verniciato nero opaco con rivestimento in cuoio nero. La seduta appare come sospesa, fluttuante, poiché semplicemente calzata nello schienale e infilata nei braccioli. Braccioli in cuoio in tinta con i rivestimenti della struttura.

A refined chair with alluring shape outlined by an accentuated depth and a slightly tilted front. The structure elegantly embraces the body and comes in matt bronzed brass finish or matt black varnished finish, with dark brown or black -coloured leather upholstery featuring visible stitching (also available black or dark brown leather). The seat fits simply into the backrest and slots into the armrests, making it look almost as though it is suspended, floating. Available in leather with matching armrests.

Lens

Coffee tables

DIM.
 Ø45 col. Petrol Green Ø45 x H 45 cm
 Ø60 col. Brown Fumè Ø60 x H 32 cm

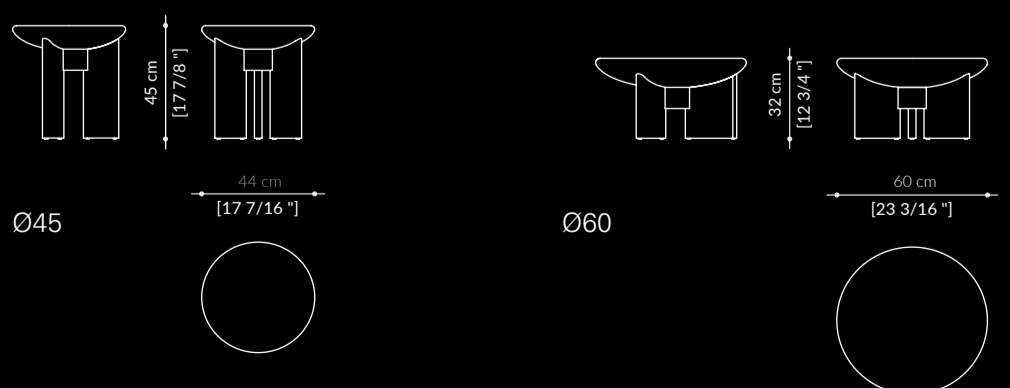

Tavolini con base in pietra vicentina levigata col. avorio formata da tre lastre verticali fissate a un disco centrale. Piano realizzato in vetro di Murano soffiato a bocca, con effetto ondulato interno che impreziosisce l'oggetto. Sottotop convesso che consente di incastonare il piano in vetro all'interno dell'alloggiamento della base.

Coffee tables with base in Vicenza stone honed col. Ivory composed by three vertical slabs fixed to a central disc. Top made of mouth-blown Murano glass, with an internal wavy effect that embellishes the object. A convex undertop allows the embedment of the glass top inside the base housing.



PAOLO CASTELLI



Golden Disc
Suspension

Alba
Table





Uffizio
Bookcase

Golden Disc Suspension

DIM.
L/W 34 x P/D 5 x H 46 cm

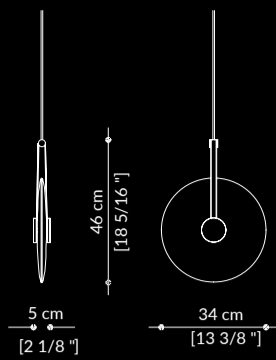

Golden Disc è una lampada a sospensione costituita da un elemento luminoso in vetro di Murano con un triplo passaggio di foglia d'oro, modellato a mano in stampo sagomato. Il vetro, che riflette la luce e la diffonde nell'ambiente, è incastonato in un disco di metallo finitura oro opaco satinato e sostenuto da un supporto metallico rivestito in pelle color sabbia. Ciascun elemento è fornito di un rosone in metallo finitura oro opaco e di un cavo elettrico di supporto della lunghezza massima di 2 m.

Golden Disc is a suspension lamp created with hand-moulded lighting element made of Murano glass, coated with three layers of gold leaf. The glass, which reflects the light and radiates it around the room, is set in a matt gold-finish metal disc and sustained by a metal support upholstered in sand-coloured leather. Each element comes with a rose made of matt gold-finish metal and an electrical support cable with a maximum length of 2 metres.

Alba Table

DIM.
Round Ø160/180 x H 75 cm
Rectangular L/W 270 x P/D 120 x H 75 cm

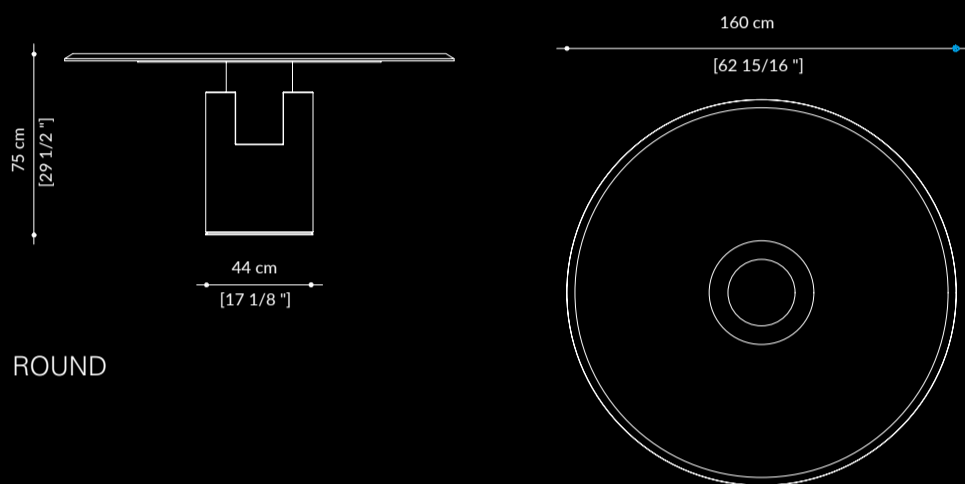

ROUND

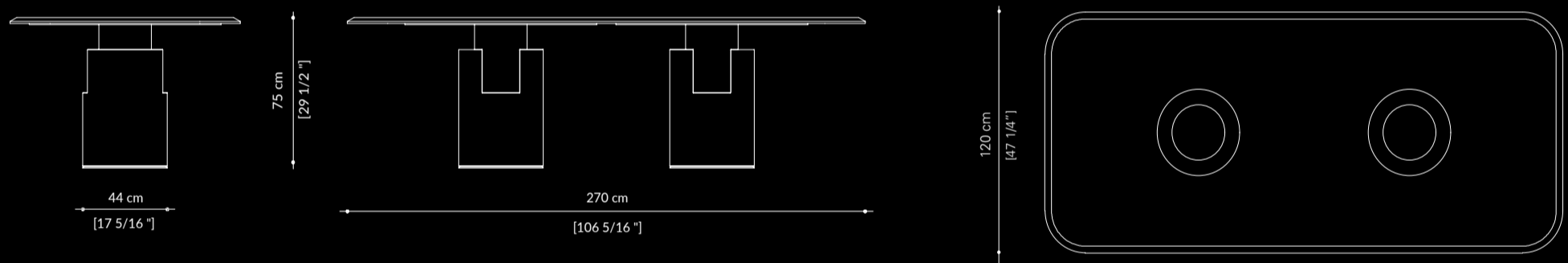

RECTANGULAR

Una miscela di materiali naturali, la pietra vicentina levigata color avorio, e industriali, il bronzo nella finitura shadow opaco, si fondono in un prodotto unico dalle forme geometriche e razionali. Il piano presenta al centro una decorazione circolare a bassorilievo, segno della mano degli artigiani che compongono la bellezza di finiture mai banali. Estremamente particolare la giunzione tra la base e il top del tavolo che genera un gradevole ed elegante dettaglio tecnico/estetico. Disponibile anche la versione con base in legno rivestita in pelle col. 634 Oasi.

A combination of natural and industrial materials, Vicenza stone honed col. Ivory and bronze in a matt shadow finish respectively, come together to create a unique product featuring geometrical and rational shapes. The centre of the table features a circular bas-relief decoration, a symbol of the skill of the craftsmen who create the most remarkably beautiful finishes. The joint between the base and the top of the table is extremely remarkable, generating a detail that is elegantly pleasing both technically and aesthetically. Also available model with wooden basement covered in leather, col. 634 Oasi.

Uffizio Bookcase

DIM.
L/W 46 x P/D 22 x H 195 cm

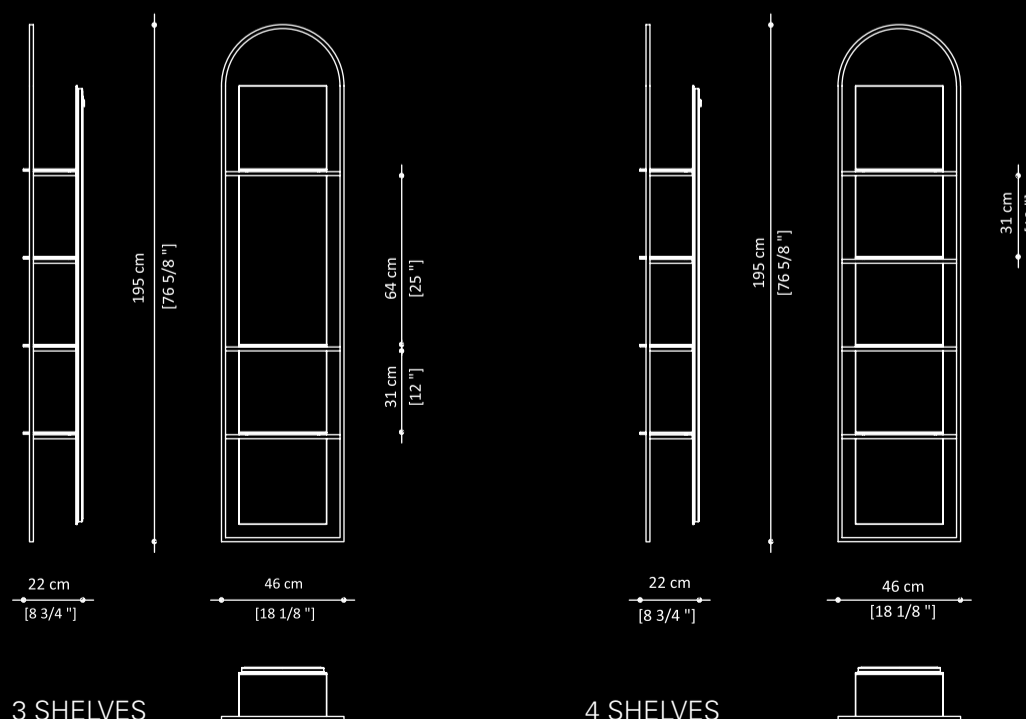

3 SHELVES

4 SHELVES

Libreria luminosa da parete composta da struttura in metallo finitura Bronze Shadow opaco disponibile anche con LED integrato, 4 ripiani in vetro trasparente col. Avana e schiena a specchio grigio satinato. Completa di fissaggio a parete. Su richiesta è disponibile la versione con 3 ripiani, per alloggiare oggetti più alti. Temperatura led 2700° K.

Wall-mounted illuminated bookcase consisting of a metal structure with a matt Bronze Shadow matt finish, available with or without LED system incorporated, with four transparent glass shelves col. Avana and a satin-finish grey mirrored glass matt back. Complete with wall fixture. On request is available the model with 3 shelves, to storage tall objects. Led colour temperature 2700°K.



PAOLO CASTELLI



Labilis
Chandelier





Labilis
Chandelier

Dione
Table

Labilis Chandelier

DIM.

4 rings composition L/W 77 x P/D 72 x H 42 cm
7 rings composition L/W 122 x P/D 115 x H 66 cm
10 rings composition L/W 130 x P/D 114 x H 82 cm
Rings dim. Ø27/ Ø43/ Ø70 x H 3 cm

Tre anelli di diverso diametro installabili singolarmente o in composizione da 4, 7 e 10 anelli. L'anello in metallo è finitura nero opaco con diffusore di luce led in policarbonato opalino bianco perimetrale. Ogni anello monta uno spot in ottone finitura bronzo ottone opaco. Gli anelli presentano tre cavi di sospensione, di cui uno di alimentazione. Cavi elettrici della lunghezza di due mt.

Three rings in different diameters can be installed separately or as composition (4, 7, 10 rings). The metal ring is in satin black finish, with light diffuser in white opal polycarbonate along the perimeter. Each ring carries a LED spot in mat brass bronze finish. Each ring has three suspension cables, one of which is a power supply one. Electric cables are two meters long.

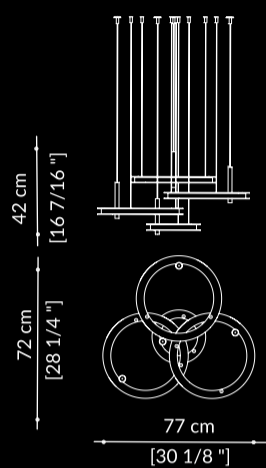

4 RINGS COMPOSITION

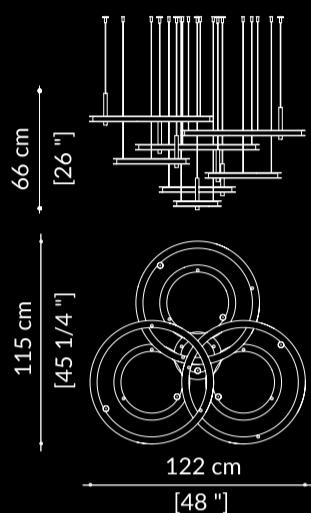

7 RINGS COMPOSITION

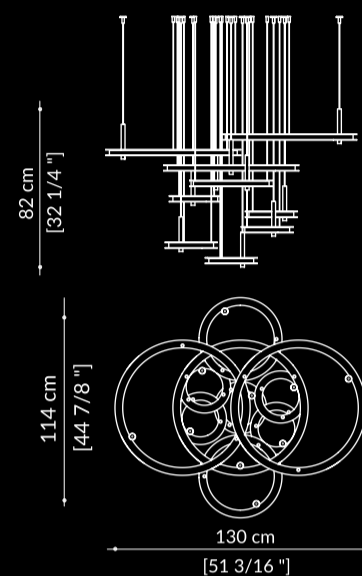

10 RINGS COMPOSITION

Dione Table

DIM.

Ø160/ 180 x P/D 14 cm
Ring 43 Ø43 x P/D 14 cm
Ring 70 Ø70 x P/D 10 cm

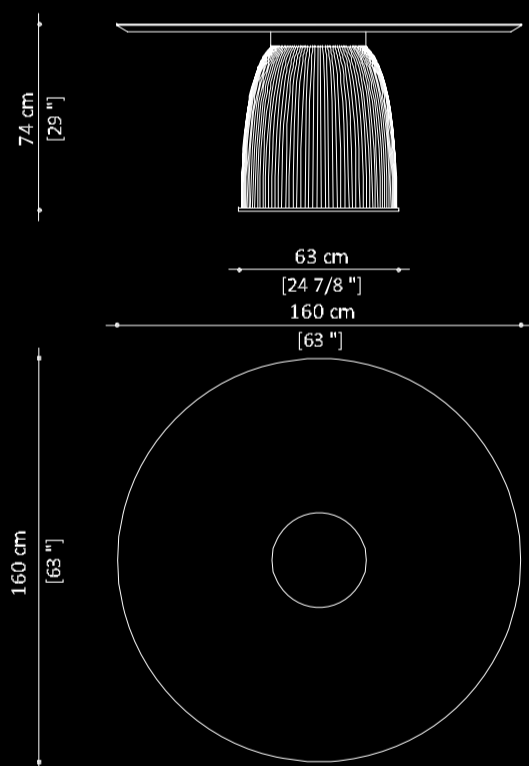

Tre anelli di diverso diametro installabili a parete singolarmente o in composizione libera. L'anello in metallo è finitura nero opaco con diffusore di luce led in policarbonato opalino bianco perimetrale. Ogni anello è fissato a parete da un cilindro metallico in finitura bronzo ottone opaco e da due distanziatori in metallo finitura nero opaco. Alimentatore remoto. Optionals su richiesta: anelli dimmerabili.

Three rings of different diameters that can be installed on the wall individually or in random composition. The metal ring has a matte black finish with a white opal polycarbonate LED light diffuser around the perimeter. Each ring is fixed to the wall by a metal cylinder in matt brass bronze finish and by two metal spacers in matt black finish. Remote power supply. Optionals on request: dimmable rings.



PAOLO CASTELLI



Soreluna
Floor lamp





Fair
Light



Labilis
Wall



Golden Cloud
Wall

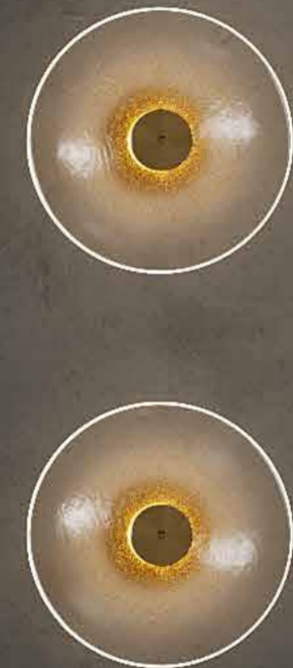

Golden Disc
Wall



Soreluna
Floor lamp

Labilis Wall

DIM.
Ring 27 Ø27 x P/D 14 cm
Ring 43 Ø43 x P/D 14 cm
Ring 70 Ø70 x P/D 10 cm

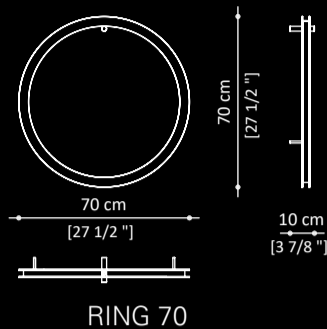
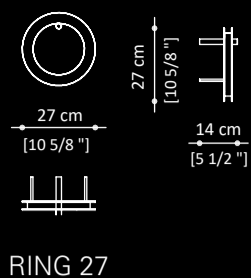
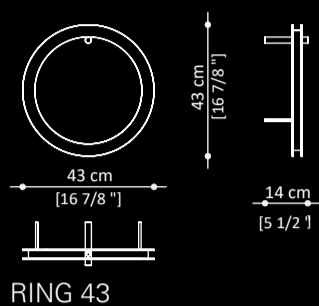

Tre anelli di diverso diametro installabili a parete singolarmente o in composizione libera. L'anello in metallo è finitura nero opaco con diffusore di luce led in policarbonato opalino bianco perimetrale. Ogni anello è fissato a parete da un cilindro metallico in finitura bronzo ottone opaco e da due distanziatori in metallo finitura nero opaco. Alimentatore remoto. Optionals su richiesta: anelli dimmerabili.

Three rings of different diameters that can be installed on the wall individually or in random composition. The metal ring has a matte black finish with a white opal polycarbonate LED light diffuser around the perimeter. Each ring is fixed to the wall by a metal cylinder in matt brass bronze finish and by two metal spacers in matt black finish. Remote power supply. Optionals on request: dimmable rings.

Fair Light

DIM.
L60 L/W 9 x P/D 10 x H 60 cm
L110 L/W 9 x P/D 10 x H 110 cm

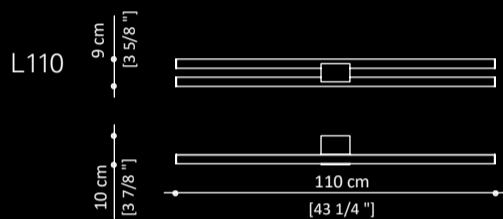
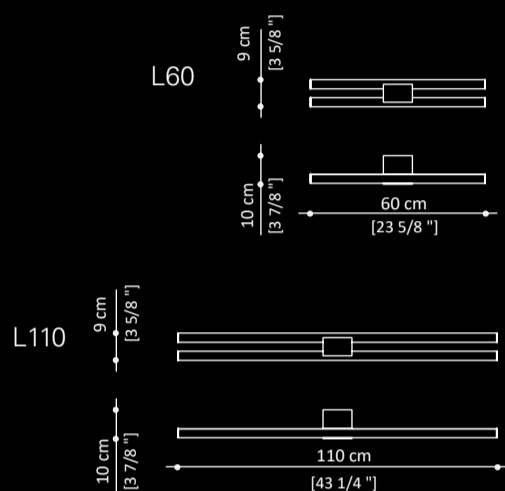

Fair Light è un corpo illuminante da parete costituito da un doppio binario di tubolari in metallo finitura nero opaco con diffusore in policarbonato opalino. La struttura di ancoraggio alla parete, che incorpora il driver, è in metallo finitura bronzo ottone opaco. L'apparecchio può essere montato sia in verticale che in orizzontale garantendo alla sorgente luminosa lineare un'ampia capacità di espressione, fornendo allo spazio energia e carattere.

Fair Light is a wall light fitting consisting of a double track made of black matt metal tubular elements with opal polycarbonate diffuser. The structure that anchors it to the wall incorporates the driver and is made of matt bronzed brass finished metal. The light can be fitted vertically or horizontally, guaranteeing the linear light source a broad capacity of expression, conveying energy and character to the room.

Golden Cloud Wall

DIM.
L/W 16 x P/D 8 x H 17 cm

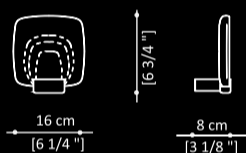

Preziosa lampada a parete interamente realizzata a mano secondo le più antiche tradizioni muranesi. L'elemento, realizzato in vetro di murano con un triplo passaggio di foglia d'oro 24Kt, è agganciato a un corpo metallico in finitura oro opaco che alloggia al suo interno la sorgente led e il proprio driver.

Precious wall lamp entirely handmade according to the most ancient Murano traditions. The element, made of Murano glass with a triple passage of 24Kt gold leaf, is hanged to a metal body in mat gold finish which hosts the LED source and its driver inside.

Golden Disc Wall

DIM.
Ø34 x P/D 8 cm

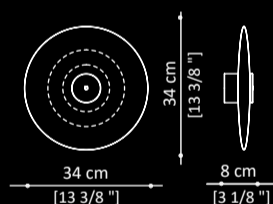

Preziosa lampada a parete interamente realizzata a mano secondo le più antiche tradizioni muranesi. L'elemento, realizzato in vetro di Murano con un triplo passaggio di foglia d'oro 24Kt, è agganciato a un corpo metallico in finitura oro opaco che alloggia al suo interno la sorgente led e il proprio driver.

Precious wall lamp entirely handmade according to the most ancient Murano traditions. The element, made of Murano glass with a triple passage of 24Kt gold leaf, is hanged to a metal body in mat gold finish which hosts the LED source and its driver inside.

Soreluna Floor lamp

DIM.
Base Ø8 x H 11 cm
H cable variable

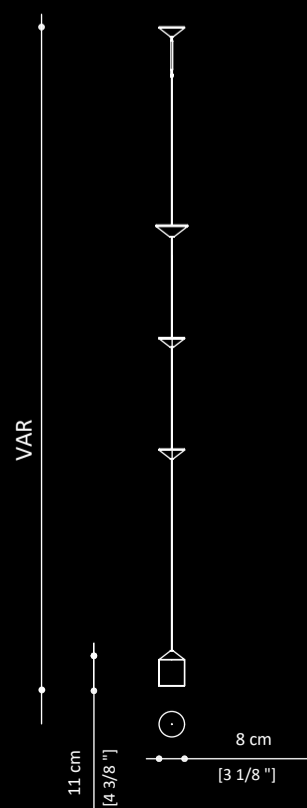

Lampada ancorata a soffitto composta da un cavo tirante centrale e contrappeso a terra realizzato in marmo Noir Saint Laurent in finitura lucida. Il cavo tirante centrale monta tre lampade coniche realizzate in metallo, con finitura oro opaco ed emissione luminosa con piastrine led circolari. Il rosone a soffitto è sempre di forma conica, in metallo finitura oro opaco.

Lamp anchored to the ceiling consisting of a central tie-rod cable and ground counterweight made of Noir Saint Laurent marble in a glossy finish. The central pull cable mounts three conical lamps made of metal, with a matt gold finish and light emission with circular LED plates. The ceiling rose is always conical in shape, in metal with a matt gold finish.



PAOLO CASTELLI



Dromo Club
Sofa





Soft Ratio
Cabinet high



Soft Ratio
Cabinet low



Dromo Club
Sofa



Soft Ratio
Sofa



Soft Ratio
Sofa composition

Soft Ratio

Cabinet high

Cabinet low

DIM.
 Low cabinet L/W 193 x P/D 59 x H 74 cm
 High cabinet L/W 122 x P/D 59 x H 170 cm

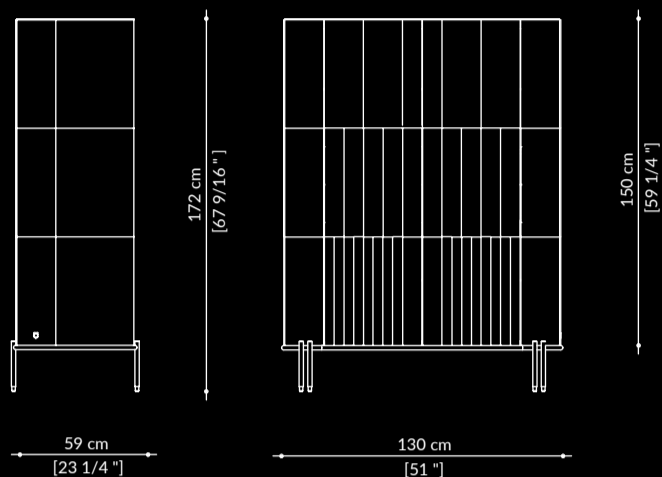

Cabinets con base in metallo finitura nero opaco con doppi piedini in metallo finitura bronzo ottone opaco. Sono disponibili con struttura in legno laccata opaca o rivestita in pelle (ante e fronte) con un pattern geometrico che richiama la struttura. L'interno è laccato in tinta. Il modello basso è attrezzato con 1 ripiano in vetro extrachiaro, mentre il fondo è in vetro specchiato col. bronzo lucido. Top in vetro retrolaccato lucido in tinta. Apertura touch delle ante con sistema push-pull. Il modello High è disponibile nella versione con 3 ripiani in vetro extrachiaro o nella versione con 2 cassetti imbottiti rivestiti internamente in microfibra in tinta e 1 ipiano in vetro extrachiaro, ed è dotato di illuminazione interna a LED, fondo in vetro specchiato col. bronzo.

Cabinets with metal base matt black finish with double metal feet matt bronzed brass finish. Models are available with wooden structure matt-laquered or leather covered (doors and front) with geometric pattern resembling the structure. Low cabinet is fitted inside with one extra-clear transparent glass shelf, while the back is made of mirrored bronze glass. Top made in glass backlaquered (same colour). The doors are opened with a push-pull touch system. High model is available inside with 3 shelves in extra clear glass or with 1 shelf in extra clear glass and 2 drawers with internal upholstery covered in microfiber, same colour. LED lighting, and back in mirrored bronze glass.

Soft Ratio

Sofa

DIM.
 Sofa 210 L/W 206 x P/D 92 x H 72 cm; H seat 45 cm
 Sofa 250 L/W x P/D 92 x H 72 cm; H seat 45 cm

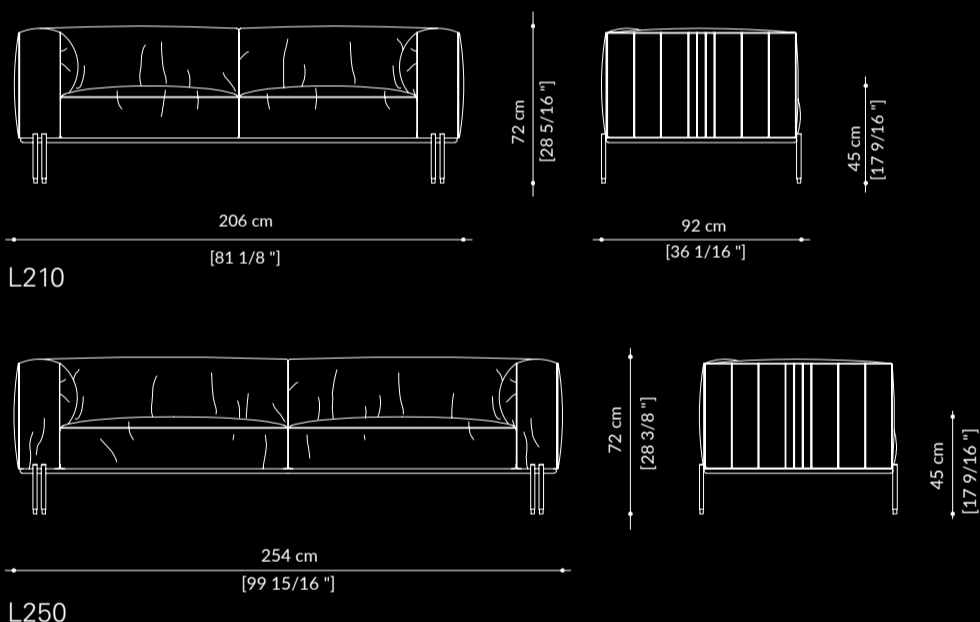

La linea Soft Ratio è un sistema di sedute componibili a 11 elementi lineari, ad angolo o a penisola che si abbinano tra loro per dare luogo a molteplici combinazioni. La base in metallo finitura nero opaco con doppi piedini in metallo finitura bronzo ottone opaco, evidenzia la leggerezza complessiva del progetto, mentre la scocca esterna in pelle con cuciture in tinta e a contrasto nel bracciolo, e l'abbondante seduta sono il frutto di una costante ricerca nel mondo del living contemporaneo. Cuscineria sedile e schienale non sfoderabile, realizzata in poliuretano espanso sagomato a quote differenziate. Nel modulo chaise longue con tavolino integrato il piano è realizzato in pietra Pece o rivestito in pelle.

The Soft Ratio range is a modular seating system consisting of 11 straight, corner or peninsula elements which can be mixed and matched to create multiple combinations. The metal base matt black finish with double metal feet matt bronzed brass finish highlights the overall lightness of the design, while the leather backrest, with matching or contrasting visible stitching (even on the armrests), and the generous seat are the result of constant research into the world of contemporary living. Seat and backrest cushion are padded in different density expanded polyurethane, covers are not removable. The chaise longue element with fixed coffee table is provided with Pietra Pece top or leather covered.

Dromo Club

Sofa

DIM.
 Sofa 3 seats L/W 242 x P/D 100 x H 82 cm; H seat 44 cm
 Sofa 4 seats L/W 349 x P/D 100 x H 82 cm; H seat 44 cm

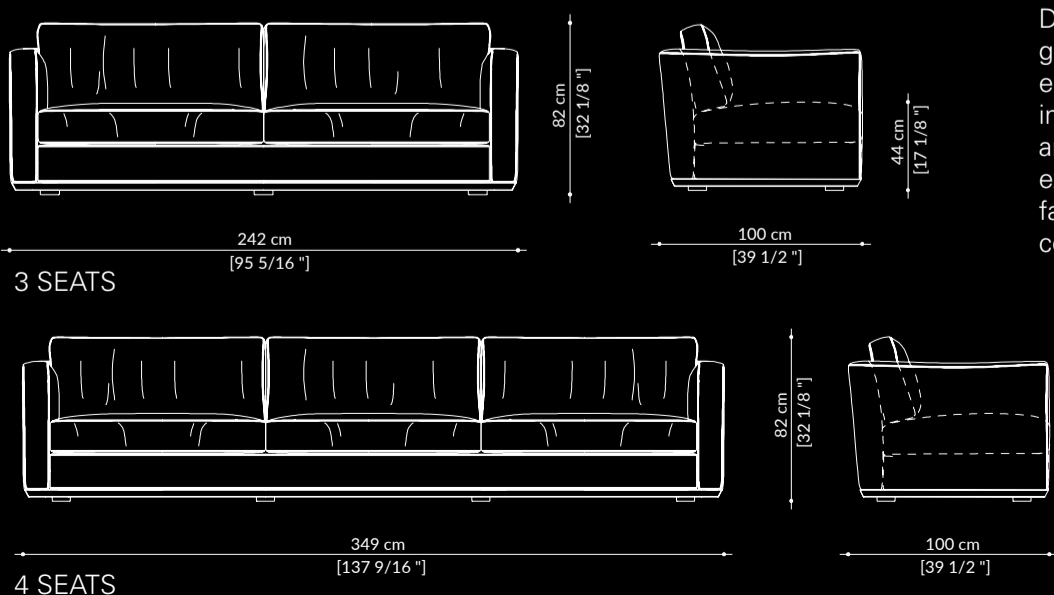

Dromo Club è una declinazione della linea Dromo, nata come omaggio al grande maestro Carlo Scarpa e alla sua città. Lo sviluppo del basamento fino a terra rafforza l'invito alla seduta e al relax, trasformandone la silhouette elegante in una proposta dal forte impatto geometrico, capace di interpretare il ruolo di protagonista in ogni ambiente. Cuscineria sedile e schienale sfoderabile, imbottitura in poliuretano espanso sagomato a quote differenziate e piuma d'oca. Il rivestimento è in pelle, nabuk o tessuto con piping in tessuto col. marrone (Ref. Fabric Sateen D6037815 Brown) o in tinta.

Dromo Club is a development of the Dromo line, conceived as a tribute to the great artist Carlo Scarpa and his home town. The extension of the base to the floor emphasises the invitation to sit down and relax, transforming the elegant silhouette into a proposal with a strong geometric impact, capable of playing the leading role in any setting. Removable seat and backrest cushion covers, padding in different density expanded polyurethane added with feather padding. Upholstered in leather, nubuck or fabric with piping in brown fabric (Ref. Fabric Sateen D6037815 Brown) or in the same colour as the upholstery.



PAOLO CASTELLI



Coral
Sofa





Gio
Chair



Arche
Dining table



Arche
Coffee tables



Arche
Coffee tables



Coral
Sofa



Coral
Armchair

Coral

Sofa & armchair

DIM.
Sofa L/W 275 x P/D 106 x H 75 cm; H seat 40 cm
Armchair L/W 110 x P/D 95 x H 70 cm; H seat 40 cm

Forme generose ed abbondanti per una serie di imbottiti il cui disegno riprende la morbidezza di una nuvola. La struttura monolitica non pesa all'occhio, grazie all'inusuale partizione degli elementi che compongono le forme: schienale, braccioli, seduta, che sembrano tra loro incastonati come elementi naturali plasmati dal tempo. Divano 3 posti con imbottitura realizzata in gomme biologiche autoestinguenti, cuffia in ovatta naturale e cinghie in juta. Rivestimento non sfoderabile in lana bouclé, tessuto misto lino o lino. Base in frassino massello ecosostenibile non selezionato, con finitura acetica.

Generous and abundant shapes for a series of upholstered furniture items with a design that brings cloud-like softness to mind. The monolithic structure is far from heavy on the eye, thanks to the unusual partitioning of the individual elements that make up the whole: backrest, armrests and seat, which seem to fit together like natural elements fashioned by time.

Three-seater sofa with cushioning made of self-extinguishing organic foam rubber covered with natural wadding, and jute webbing. Upholstered with natural bouclé wool, linen-blended fabric or linen. This upholstery cannot be removed. Wood basement in ashwood with acetic finish.

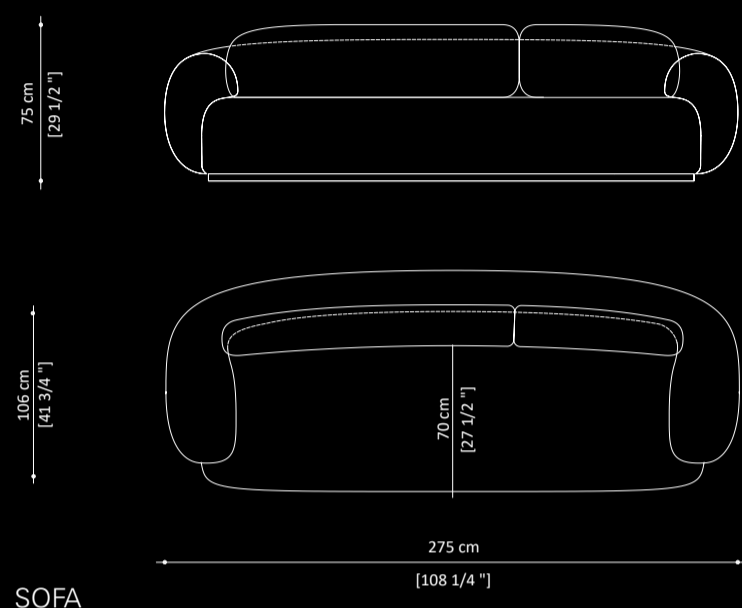

SOFA

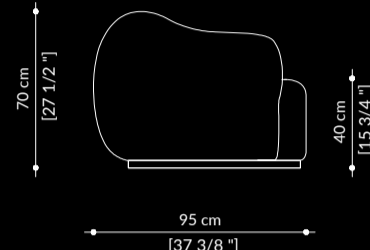
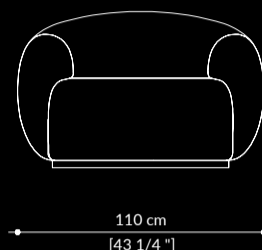
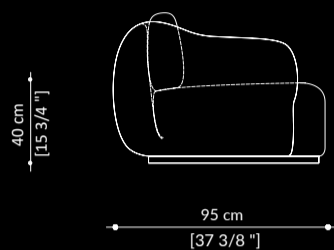

ARMCHAIR

Gio

Chair

DIM.
L/W 38 x P/D 51 x H 87 cm;
H seat 46 cm

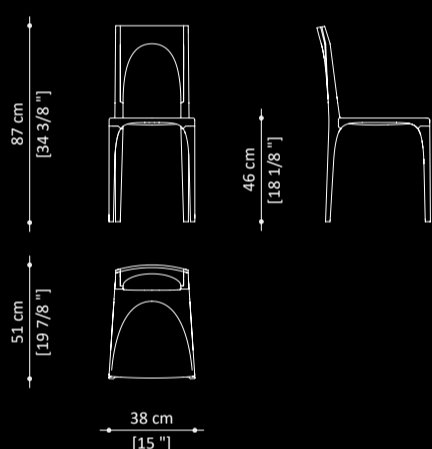

Sedia da pranzo realizzata interamente in massello di frassino ecosostenibile, disponibile in tre versioni: con finitura acetica, sbiancata o tinto noce con finitura poro aperto. Con questo procedimento il poro del legno viene volutamente lasciato aperto permettendo all'essenza di mantenere il suo aspetto naturale.

Dining chair made entirely of solid eco-friendly ash discarded, available in three options: natural ash with acetic finish, bleached or walnut-stained version with open pore finish. By this process the wood pores are deliberately left open, thereby allowing the veneer to retain its natural appearance.

Arche

Dining & coffee table

DIM.
Dining table Ø110 x H 74 cm
Side table 45 Ø45 x H 50 cm
Side table 50 Ø50 x H 45 cm
Coffee table 90 Ø90 x H 40 cm

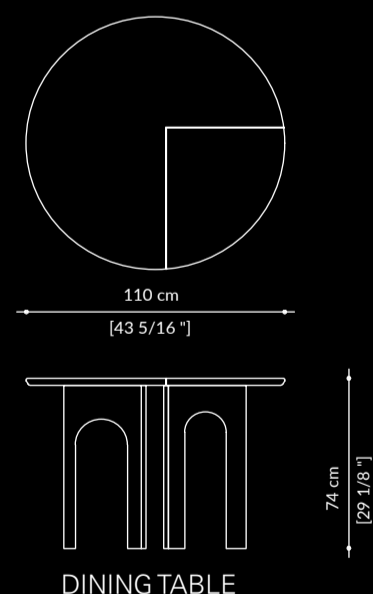

DINING TABLE

Tavoli caratterizzati da geometrie precise e pulite, in cui l'arco diventa struttura portante come in un'architettura razionalista. La struttura è realizzata da lamiere metalliche disposte a croce, sagomate ad arco a taglio laser, in finitura color champagne a satinatura orbitale. Il piano può essere realizzato in pietra di Vicenza sabbiata col. grigio o levigata col. avorio. In alternativa è disponibile la versione in pietra ricostituita o carbone naturale ricostituito con trucioli di ottone da recupero. Una serie di decori metallici col. champagne satinato impreziosisce il top in un gioco di contrasti tra materiali.

Dining, side and coffee tables characterised by precise, clear-cut geometries, in which the arch becomes the load-bearing structure typical of rationalist architecture. The metal structure is built in a cross-shaped, laser-cut arch arrangement, presented in a champagne colour with an orbital satin finish. The top is made of Vicenza stone sandblasted col. light grey or honed col. ivory. Also available the top made in reconstituted coarse grained stone or natural carbon reconstituted with recycled brass shavings. Metallic inserts col. champagne mat embellish the top with a delightful contrasting effect between the materials.

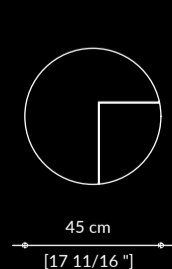

SIDE TABLE Ø45

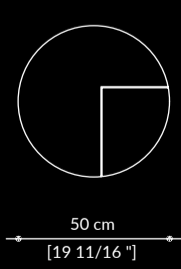
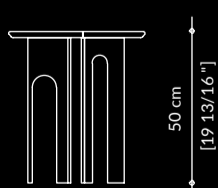

SIDE TABLE Ø50

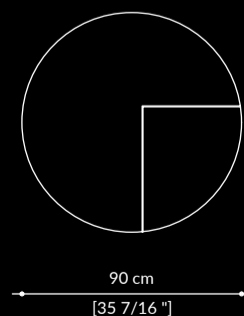
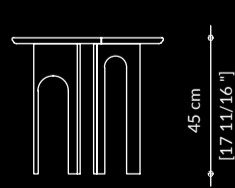

COFFEE TABLE Ø90





Vao
Sofa 380





Selima
Console



Selima
Chair



Kaala
Lamp



Hyperbole
Lamp



Vao
Sofa 250



Vao
Sofa 380



Vao
Pouf



Vao
Armchair

Vao

Sofa 380, Sofa 250

Armchair, Pouf

DIM.
Sofa 380 L/W 380 x P/D 187 x H 74 cm; H seat 40 cm
Sofa 250 L/W 250 x P/D 109 x H 74 cm; H seat 40 cm
Armchair L/W 75 x P/D 77 x H 74 cm; H seat 40 cm
Pouf Ø100 x H 40 cm

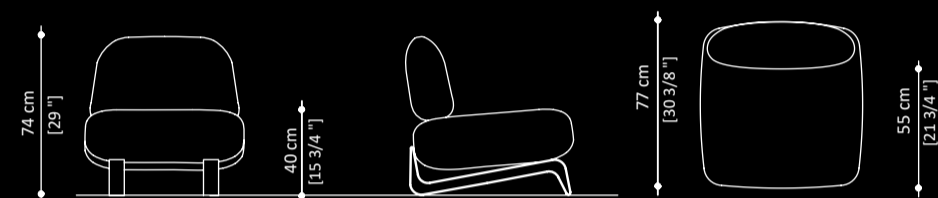
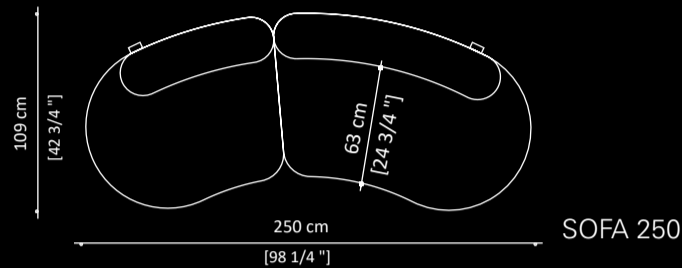
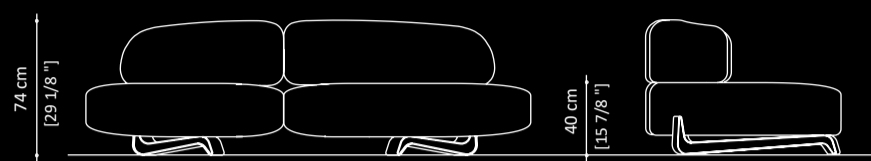
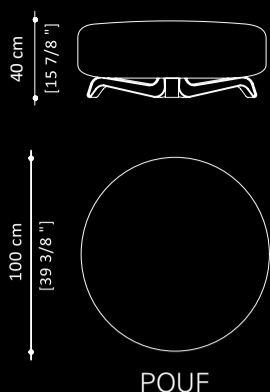

ARMCHAIR

Serie di divano e poltrona dalla forma sinuosa e dimensioni generose, poggia su una struttura con gambe realizzate in frassino massello ecosostenibile non selezionato, con finitura acetica, le cui imperfezioni assumono un'evidenza estetica preponderante. Imbottitura realizzata con gomme biologiche autoestinguenti, cuffia in ovatta naturale e cinghie in iuta. Rivestimento non sfoderabile in lana bouclé, tessuto misto lino o lino.

Three-seat sofa with a sinuous shape and ample dimensions, supported by a structure with legs made of discarded eco-friendly solid ash with acetic finish, whose imperfections give it a striking aesthetic appearance. Padding made with eco-friendly and self-extinguishing rubber, batting made of natural wadding, and straps made of jute. Upholstered with natural bouclé wool, linen-blended fabric or linen. This upholstery cannot be removed.

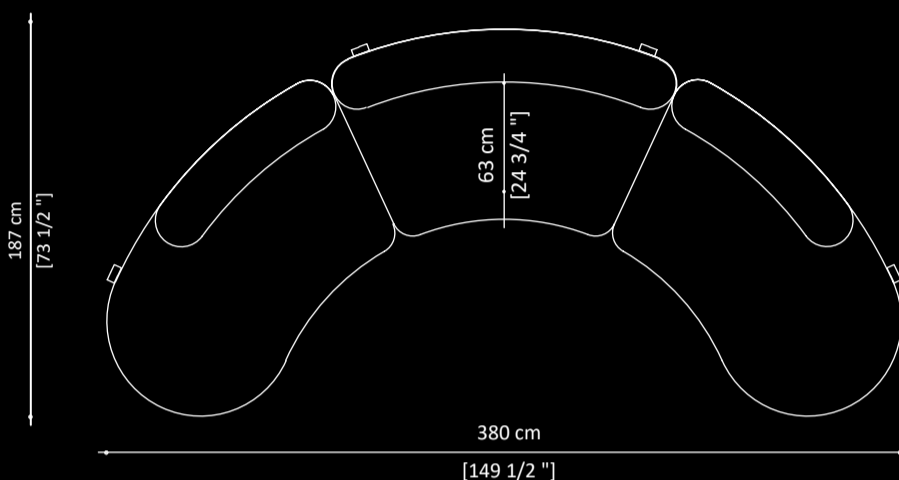
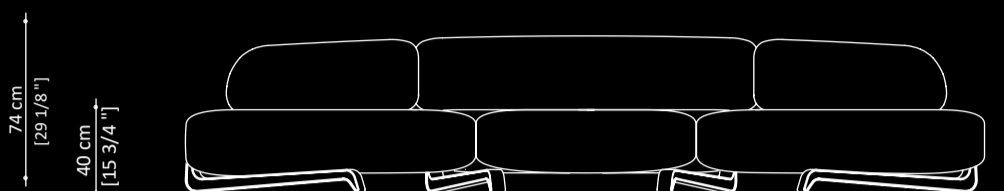

SOFA 380

Selima

Console

DIM.
L/W 160 x P/D 38 x H 80 cm

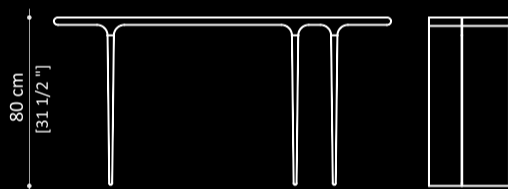
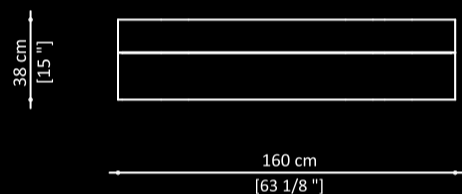

Console in frassino ecosostenibile non selezionato, disponibile in tre versioni: con finitura acetica, sbiancata o tinto noce con finitura poro aperto. Con questo procedimento il poro del legno viene volutamente lasciato aperto permettendo all'essenza di mantenere il suo aspetto naturale. I profili della console sono impreziositi da inserti metallici color champagne opaco.

Console made of solid eco-friendly ash discarded, available in three options: natural ash with acetic finish, bleached or walnut-stained version with open pore finish. By this process the wood pores are deliberately left open, thereby allowing the veneer to retain its natural appearance. The console frames are embellished with matt champagne-coloured metal inserts.

Selima

Chair

DIM.
L/W 49 x P/D 51 x H 85 cm;
H seat 46 cm

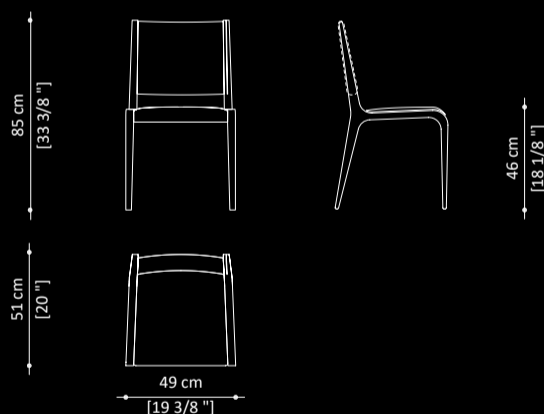

Sedia da pranzo realizzata interamente in massello di frassino ecosostenibile, disponibile in tre versioni: con finitura acetica, sbiancata o tinto noce con finitura poro aperto. Con questo procedimento il poro del legno viene volutamente lasciato aperto permettendo all'essenza di mantenere il suo aspetto naturale. Schienale e seduta con rivestimento non sfoderabile in lana bouclé, tessuto misto lino, lino o econabuk. I dettagli della struttura sono in metallo color champagne opaco.

Dining chair made entirely of solid eco-friendly ash discarded, available in three options: natural ash with acetic finish, bleached or walnut-stained version with open pore finish. By this process the wood pores are deliberately left open, thereby allowing the veneer to retain its natural appearance. Back and seat with unremovable covering in bouclé wool, blended linen, linen fabric or econabuk. Frame details made of champagne-coloured metal, polished finish.

Kaala

Lamp

DIM.
Ø36 x H 80 cm

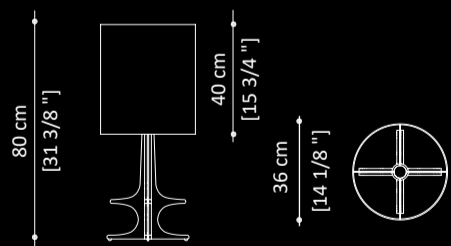

Lampada con base in metallo color champagne opaco, ricoperto da lastre realizzate in ceramica artigianale di Vietri smaltata bianca o gialla. L'accostamento dei due materiali crea un elegante inserto metallico. Il paralume -100% naturale- è realizzato in fibra di canapa nepalese color verde o giallo. Sorgente luminosa E27.

Lamp with structure made in matt champagne-coloured metal, covered by handmade white or yellow-glazed Vietri ceramic. The combination of two materials creates an elegant metal trim. The 100% natural lampshade is made of Nepalese hemp fibre, green or white. Lighting source E27 bulb.

Hyperbole

Lamp

DIM.
Sofa 380 L/W 67 x P/D 32 x H 80 cm

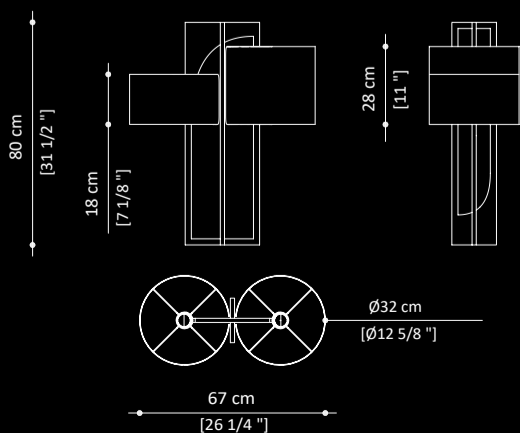

Lampada con base in granito antico nero a texture rigata. Il paralume -100% naturale- è realizzato in fibra di banano e presenta una finitura interna rame satinato opaco. Sorgente luminosa E27.

Lamp with base made of black antique granite striped. The 100% natural lampshade is made of banana leaf fibre and internally coloured copper. Lighting source E27 bulb.



PAOLO CASTELLI



Icone
Luminose





Icone
Luminose



Icone
Silenziose

Appendiabito
Coat rack



Strapuntino
Side table



Scranno
Stool



Vassoio
Tray



Tugurium
Cot



Icone Luminose

DIM.
01 Ø 24 x H 123 cm
02 Ø 24 x H 94 cm
03 Ø 24 x H 132 cm
04 Ø 24 x H 126 cm

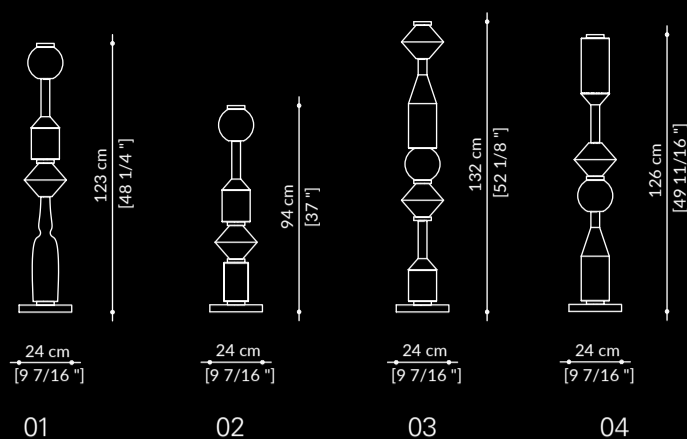

Lampade da terra con struttura in metallo finitura oro opaco satinato, composta da vasi in vetro soffiato di Murano.

Floor lamps made of metal structure in matt gold finish. It is composed of vases in Muranese blown glass.

Icone Silenziose

DIM.
B01 Ø13 H48 cm; Col. Blue-grey
B02 Ø13 H37 cm; Col. Brown Fumè
B03 Ø12 H48 cm; Col. Petrol Green
B04 Ø13 H41 cm; Col. Medium Amber
B05 Ø13 H41 cm; Col. Medium Amber

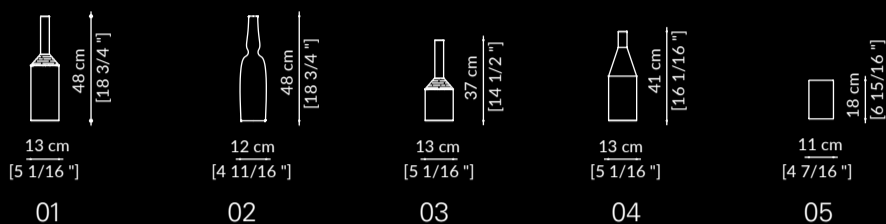

Vasi decorativi in vetro soffiato di Murano.
Decorative vases in blown Muranese glass.

Appendiabito Coat rack

DIM.
L/W 62 x P/D 53 x H 165 cm

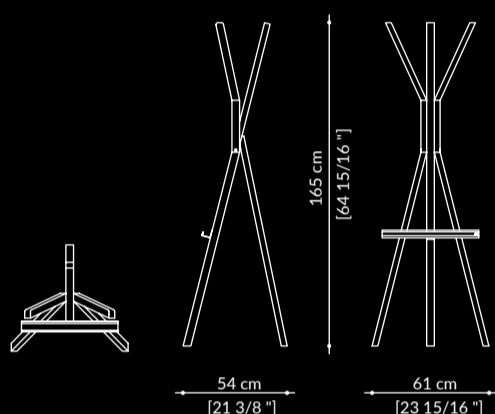

Appendiabito in legno finitura tinto noce con dettagli in metallo in finitura bronzo ottone opaco. Portata massima 8 kg.

Coat rack in wood walnut-stained finish with metal details in matt bronzed brass. Maximum load 8 kg.

Strapuntino Side table

DIM.
L/W 29 x P/D 46 x H 76 cm;
H top 55 cm

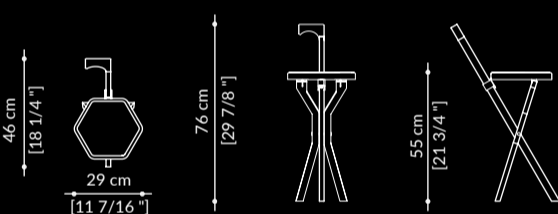

Tavolinetto pieghevole con manico in legno tinto noce con dettagli in metallo in finitura bronzo ottone opaco. Seduta in tessuto.

Small wooden folding table with handle in walnut-stained finish. Metal details in matt bronzed brass. Seat in fabric.

Scranno Stool

L/W 46 x P/D 51 x H 48 cm

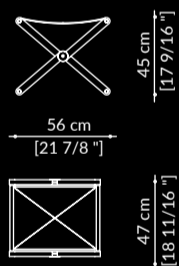

Sgabello pieghevole con struttura in legno finitura tinto noce, inferiormente verniciata opaca col. Sabbia (Ral 1019). Dettagli in metallo finitura bronzo ottone opaco. Seduta in cuoio col. Sabbia. Cuciture in tinta.

Folding stool in wood -walnut-stained finish- bottom varnished matt col. Sand- Ral 1019. Seat in leather col. Sand with elegant matching stitches.

Vassoio Tray

DIM.
Coffee table Ø75 x H 49 cm
Luggage rack L/W 56 x P/D 57 x H 45 cm

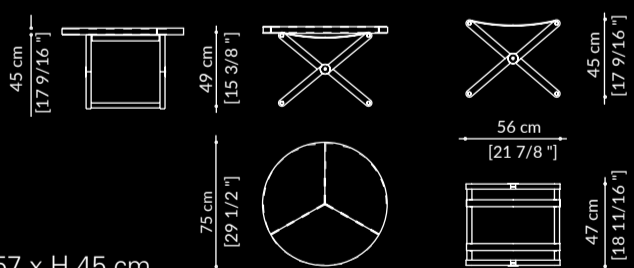

Tavolino composto da vassoio in legno rivestito in cuoio color Sabbia e porta-vassoio in legno massello in finitura tinto noce, inferiormente verniciata opaca col. Sabbia (Ral 1019). Dettagli in metallo finitura bronzo ottone opaco. La struttura di legno è adatta anche come portavaligia. Lacci di supporto in cuoio color Sabbia.

Coffee table composed by a wooden tray covered in leather color Sand and tray holder in solid wood in walnut-stained finish, bottom varnished matt col. Sand- Ral 1019. Metal details in matt bronzed brass finish. The wooden structure is suitable as luggage rack. Leather support laces in col. Sand.

Tugurium Cot

DIM.
L/W 196 x P/D 56 x H 45 cm

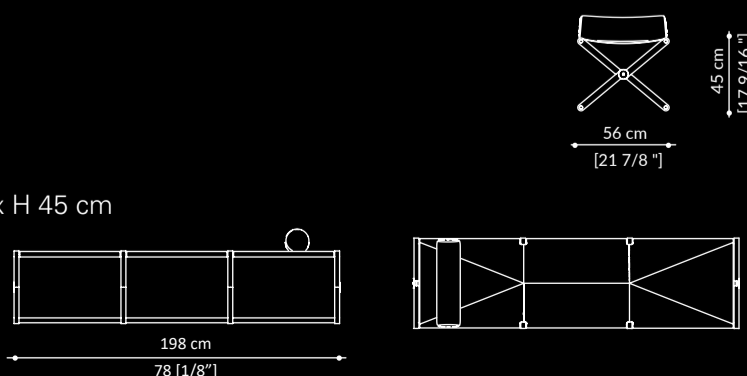

Branda pieghevole con struttura in legno finitura tinto noce, inferiormente verniciata opaca col. Sabbia (Ral 1019). Dettagli in metallo finitura bronzo ottone opaco. Rivestimento superiore in cuoio col. Sabbia e cuciture in tinta.

Folding cot with frame made in wood -walnut-stained finish- bottom varnished matt col. Sand- Ral 1019. Metal details in matt bronzed brass finish. Seating in leather color Sand with matching stitches.



PAOLO CASTELLI